

Skinner Valve

Two-Way, Three-Way and Four-Way Solenoid Valves

Catalog CFL00897

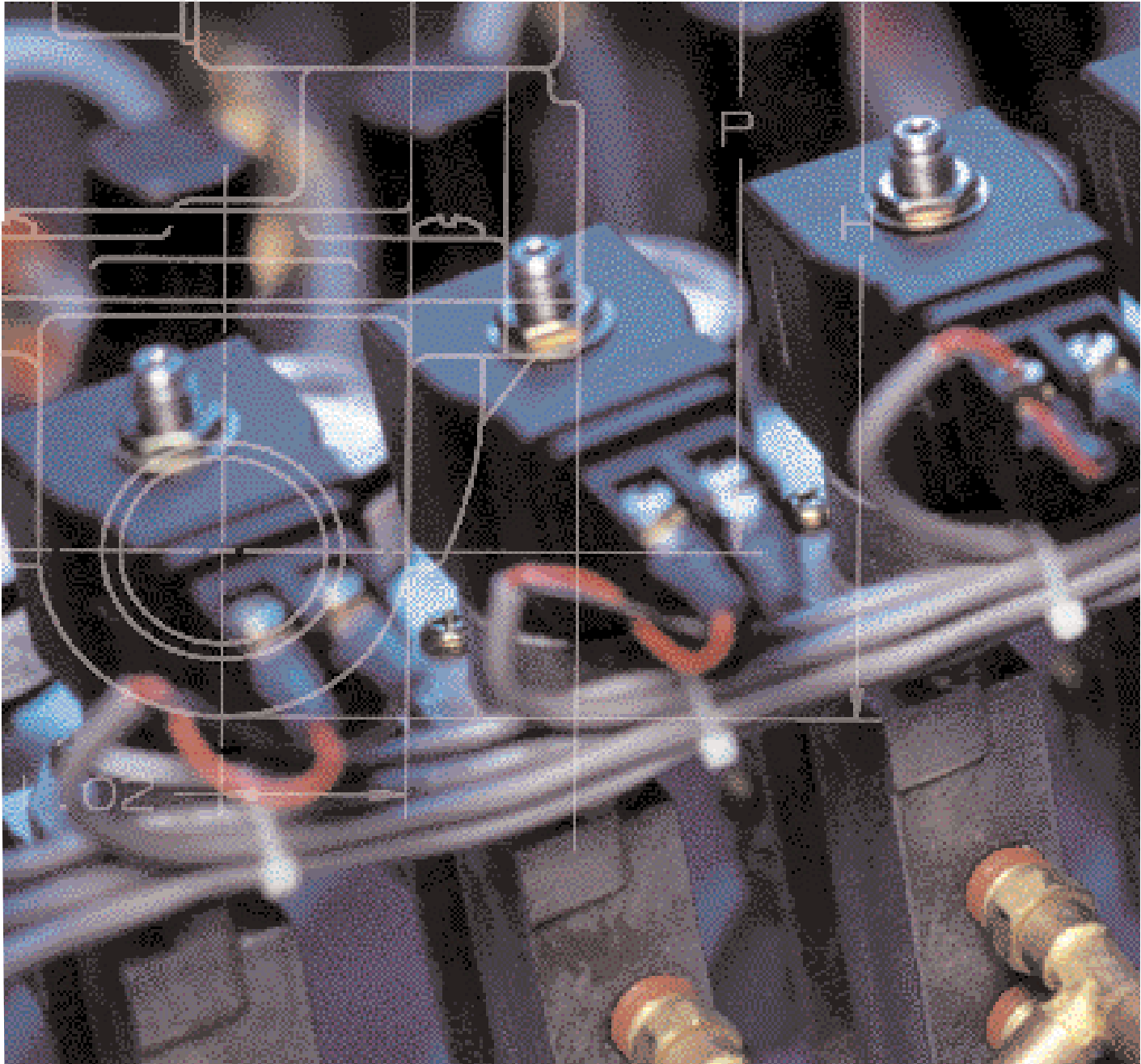

Skinner Valve Introduction

Table of Contents

Product Overview	1
Condensed Valve Listing	2-8
Valve Ordering Information	9-11
7000 Series Ordering	9
3000 Series Ordering	10
A, B, C, MB and V9 Ordering	10
Intrinsically Safe Ordering	11
7000 Series Coil Information	12-13
3000 Series Coil Information	13
Skinner Two-Way Valve Specifications	15-48
Skinner 7000 Series Valves	15-40
General Purpose Valves	15-27
Hot Water and Steam Valves	28-32
High Pressure Valves	33-35
Anti-Water Hammer Valves	36-37
Manual Reset Valves	38
Remote Pressure Valves	39
Skinner 3000 Series Valves	40-41
Skinner B-Series Valves	42
Skinner C-Series Valves	43
Skinner LB27 Zero Delta P Valves	44
Skinner Three-Way Valve Specifications	46-72
Skinner 7000 Series Valves	46-63
General Purpose Valves	46-57
Quick Exhaust Valves	58
High Pressure Valves	59-60
Manual Reset Valves	61-62
Remote Pressure Valves	63
Skinner 3000 Series Valves	64-66
Skinner B-Series Valves	67-68
Skinner C-Series Valves	69-70
Skinner A-Series Valves	71-72
Skinner Four-Way Valve Specifications	74-84
Skinner 7000 Series Valves	74-80
Direct Acting Valves	74-75
Pilot Operated Valves	76-80
Skinner V-9 Series Valves	81-84
Skinner Specialty Valve Specifications	86-90
Skinner 7000 Series Valves	86
Hydraulic Two-Way Valves	86
Dry Operator Valves	87-89
Hydraulic Three-Way Valves	90
Skinner Dual-Flow Valves	91
Skinner BP Proportional Valves	92-93
Skinner Intrinsically Safe Valves	94-107
Intrinsically Safe Two-Way Valves	95-96
Intrinsically Safe Three-Way Valves	97-98
Intrinsically Safe Special Purpose Valves	99
Intrinsically Safe Four-Way Valves	100-101
Coil and Enclosure Information	102-107
Skinner A-10 Series Valves	108-109
Skinner MB Series Valves	110-111
Electropneumatic Pressure Regulator (EPP3)	112-113
Technical Information	114-128
Fluid Compatibility	116-117
7000 Series Numbering System	119-120
7000 Series Electrical Options	121
3000 Series Numbering System	126
Opportunity Data Sheet	128
Terms and Conditions of Sale	129

Fluid Control Division

Skinner has been recognized as a leader in solenoid valve technology since 1949 when they first started manufacturing solenoid valves.

The Skinner and Lucifer facilities are both vertically integrated, manufacturing a large percentage of their component parts complete from the raw material level. This permits a high degree of control over the quality and availability of products. Each facility is equipped with a complete staff of experienced design engineers permitting rapid completion of customized valve designs for specific user requirements. Also, each facility has well equipped evaluation and testing laboratories to ensure proper valve operation, long cycle life, and optimum reliability of the product in the application.

With many affiliates worldwide, an extensive distribution network, and broad product breadth, Parker is in a unique position to service the world's requirements for solenoid valves.

WARNING

FAILURE OR IMPROPER SELECTION OR IMPROPER USE OF THE PRODUCTS AND/OR SYSTEMS DESCRIBED HEREIN OR RELATED ITEMS CAN CAUSE DEATH, PERSONAL INJURY AND PROPERTY DAMAGE.

This document and other information from Parker Hannifin Corporation, its subsidiaries and authorized distributors provide product and/or system options for further investigation by users having technical expertise. It is important that you analyze all aspects of your application and review the information concerning the product or system in the current product catalog. Due to the variety of operating conditions and applications for these products or systems, the user, through its own analysis and testing, is solely responsible for making the final selection of the products and systems and assuring that all performance, safety and warning requirements of the application are met.

The product described herein, including without limitation, product features, specifications, designs, availability and pricing, are subject to change by Parker Hannifin Corporation and its subsidiaries at any time without notice.

Offer of Sale

The items described in this document are hereby offered for sale by Parker Hannifin Corporation, its subsidiaries or its authorized distributors. This offer and its acceptance are governed by the provisions stated on the separate page of this document entitled "Terms and Conditions of Sale". (See page 129.)

Fluid Control Division Product Lines

The Skinner 7000 Series

7000 Series products have been designed to offer customers the ultimate in performance, versatility and quality. Every valve is engineered for optimal operation, is constructed with modern machinery that uses stringent processes, and provides standard features not offered in any competitive line. The 7000 Series is truly a world class product offering.

A, B, C, MB and V9 Products

Skinner A, B, C, MB and V9 line of solenoid valves include a wide variety of valve types, sizes and functional variations. They include 2-, 3- and 4-way valves designed specifically for use in hydraulic and pneumatic systems, as well as many varieties of general service products.

Additional Fluid Control Division Products and Catalogs

Skinner Valve Actuation Series Catalog

The Valve Actuation Series includes a variety of three- and four-way valves designed with unique features and options enhancing their performance, operational reliability and application versatility.

The Series includes 7700 and 7300 Line, All-Ports-In-Body valves, Intrinsicly Safe valves, Quick Exhaust valves, Direct Mount valves with NAMUR interface, Ultra Low-Power valves, along with a host of accessories and options. In addition, to satisfy the most stringent environmental demands, most valves are available in a choice of body materials including brass, stainless steel, and aluminum, as well as a variety of elastomeric seals.

Skinner Intrinsicly Safe Series

When designed into an intrinsicly safe system, Skinner Valve's Intrinsicly Safe solenoid valves provide a number of significant performance advantages: Low-Power Consumption; Low Temperature Rise; a Wide Range of Sizes; a Variety of Mounting Possibilities; Media Compatibility; a Wide Selection of Options; and Watertight Construction.

Skinner Intrinsicly Safe solenoid valves have approvals for use in the United States and Canada in hazardous classifications for Classes I, II, III, Division 1 and 2, and in the United Kingdom for Division 0, 1 and 2. In Europe our valves are approved according to CENELEC standards.

The Skinner 3000 Series

When reliable performance, economy and a compact design count, depend on Skinner Valve's 3000 Series. Developed with fully interchangeable components, the 3000 Series is user-flexible by design.

The Skinner 3000 Series is available in two- and three-way configurations, and is particularly adaptable to original equipment manufacturers involved in the development of fluid power/fluid control equipment in dispensing, blending, bio-medical and dental applications.

Gold Ring Two-Way, Three Way and Four Way Solenoid Valves

A wide range of two-way, three-way and four-way Gold Ring solenoid valves in brass or stainless steel. These valves have a wide variety of seal and disc materials, ensuring a standard valve for most applications. Special purpose valves include long life, quiet operation, cryogenic and vacuum service solenoid valves.

Angle Body Valves and Proportional Control Valves

The Parker Angle Body Valves are externally pneumatically piloted 2 way angle body valves. These are available for on - off or proportional control applications, powered pneumatically or electrically. Available with stainless steel or bronze bodies, the Parker valves meet a diverse range of applications.

Technical Reference Manual

The Skinner Technical Reference Manual provides an overview of solenoid valve technology. Material provided includes a review of the components and functional varieties of solenoid valves available from Skinner Valve. In addition, the manual contains information considered essential in selecting valves for most standard applications.

Skinner Condensed Valve Listing

Pipe Size NPT	Pressure Vessel Number	Page	Operating Pressure Differential (PSI)			
			Min.	AC+ psi	DC+ psi	Body Mat'l
Two-Way Hydraulic Valves						
1/8"	A126LB13001	108	0	-	3000	SS
1/8"	A12LB13002	108	0	3000	-	SS
1/8"	71211SN1MM00	86	0	1000	1000	SS
1/8"	71221SN1MM00	86	0	1000	1000	SS
1/8"	A116LB13001	108	0	-	3000	SS
1/8"	A11LB13002	108	0	3000	-	SS
Two-Way Dual Purpose Valves						
1/8"	71235SN1AN00	19	0	400	400	SS
1/8"	71235SN1EN00	19	0	180	180	SS
1/8"	71235SN1GN00	19	0	110	110	SS
1/8"	71235SN1KN00	19	0	70	70	SS
1/8"	71235SN1MN00	19	0	45	45	SS
1/4"	71235SN2AN00	19	0	400	400	SS
1/4"	71235SN2EN00	19	0	180	180	SS
1/4"	71235SN2GN00	19	0	110	110	SS
1/4"	71235SN2KN00	19	0	70	70	SS
1/4"	71235SN2MN00	19	0	45	45	SS
Two-Way Normally Closed Valves						
Flange	7121FBF4GF00	15	0	1000	435	BR
Flange	7121FBF4NF00	15	0	365	125	BR
1/8"	71216SN1BL00	33	0	3000	2500	SS
1/8"	71216SN1FU00	33	0	1500	1000	SS
1/8"	71216SN1GL00	33	0	1250	500	SS
1/8"	7121KBN1GF00	15/33	0	1000	435	BR
1/8"	71215SN1EF00	16/33	0	1000	520	SS
1/8"	3121BBN1AN00	40	0	800	800	BR
1/8"	3121BSN1AN00	40	0	800	800	SS
1/8"	71215SN1GF00	16/33	0	700	350	SS
1/8"	7121KBN1LR00	33	0	500	175	BR
1/8"	71216SN1JT00	33	0	500	200	SS
1/8"	3121BBN1EN00	40	0	500	500	BR
1/8"	3121BSN1EN00	40	0	500	500	SS
1/8"	3121BSA6EN00	41	0	500	500	SS
1/8"	71215SN1EN00	16	0	450	450	SS
1/8"	B2DA1400	42	0	400	400	SS
1/8"	7121KBN1NF00	15	0	365	125	BR
1/8"	71215SN1GN00	16	0	350	350	SS
1/8"	3121BBN1GN00	40	0	300	300	BR
1/8"	3121BSN1GN00	40	0	300	300	SS
1/8"	3121BSA6GN00	41	0	300	300	SS
1/8"	71215SN1KN00	16	0	275	275	SS
1/8"	C2*1277	43	0	275	-	BR
1/8"	71215SN1KF00	16	0	260	130	SS
1/8"	B2DA1250	42	0	250	250	SS
1/8"	C2*1251	43	0	-	250	BR
1/8"	71215SN1MF00	16	0	200	100	SS
1/8"	71215SN1MN00	16	0	200	150	SS
1/8"	3121BBN1JN00	40	0	200	200	BR
1/8"	3121BSN1JN00	40	0	200	200	SS
1/8"	B2DA1175	42	0	175	175	SS
1/8"	3121BBN1LN00	40	0	175	175	BR
1/8"	3121BSN1LN00	40	0	175	175	SS
1/8"	3121BSA6LN00	41	0	175	175	SS
1/8"	C2*1132	43	0	130	-	BR
1/8"	71215SN1QN00	16	0	110	60	SS
1/8"	3121BBN1NN00	40	0	100	100	BR
1/8"	3121BSN1NN00	40	0	100	100	SS

Pipe Size NPT	Pressure Vessel Number	Page	Operating Pressure Differential (PSI)			
			Min.	AC+ psi	DC+ psi	Body Mat'l
1/8"	C2*1092	43	0	90	-	BR
1/8"	C2*1081	43	0	-	80	BR
1/8"	71215SN1SN00	16	0	80	25	SS
1/8"	C2*1062	43	0	60	-	BR
1/8"	B2DA1052	42	0	50	-	SS
1/8"	C2*1051	43	0	-	50	BR
1/8"	3121BBN1QN00	40	0	50	50	BR
1/8"	3121BSN1QN00	40	0	50	50	SS
1/8"	3121BSA6QN00	41	0	50	50	SS
1/8"	71215SN1VN00	16	0	40	10	SS
1/8"	C2*1031	43	0	-	30	BR
1/8"	B2DA1026	42	0	-	25	SS
1/4"	71216SN2BL00	33	0	3000	2500	SS
1/4"	73216BN2MT00	34	5	1500	800	BR
1/4"	73216SN2MT00	34	5	1500	800	SS
1/4"	71216SN2FU00	33	0	1500	1000	SS
1/4"	71216SN2GL00	33	0	1250	500	SS
1/4"	7121KBN2GR00	33	0	1100	435	BR
1/4"	7121KBN2GF00	15/33	0	1000	435	BR
1/4"	71215SN2EF00	15/33	0	1000	520	SS
1/4"	7121KBN2JR00	33	0	700	260	BR
1/4"	71215SN2GF00	15/33	0	700	350	SS
1/4"	7321HBN2SN00	34	5	600	435	BR
1/4"	7121KBN2LR00	33	0	500	175	B
1/4"	71216SN2JT00	33	0	500	200	SS
1/4"	71215SN2EN00	16	0	450	450	SS
1/4"	7121KBN2NF00	15	0	365	125	BR
1/4"	7121KBN2NR00	33	0	365	125	BR
1/4"	71215SN2GN00	16	0	350	350	SS
1/4"	73212BN2MN00	22	5	300	300	BR
1/4"	73212SN2MN00	22	5	300	300	SS
1/4"	7321KBY61640	24	3	300	45	BR
1/4"	71215SN2KN00	16	0	275	275	SS
1/4"	71215SN2KF00	16	0	260	130	SS
1/4"	71215SN2MF00	16	0	200	100	SS
1/4"	71215SN2MN00	16	0	200	150	SS
1/4"	7321KBN2RN00	22	3	150	60	BR
1/4"	7121KBN2NV00	15	0	145	125	BR
1/4"	7121KBN2QV00	15	0	120	60	BR
1/4"	71215SN2QN00	16	0	110	60	SS
1/4"	7121KBN2SV00	16	0	80	30	BR
1/4"	71215SN2SN00	16	0	80	25	SS
1/4"	71214TN2KT00	88	0	70	70	T
1/4"	71215SN2VN00	16	0	40	10	SS
1/4"	71214VN2ST00	88	0	20	20	SS
1/4"	71215SN21N00	16	0	20	3	SS
1/4"	71214TN2ST00	88	0	20	20	T
3/8"	7321HBN3TN00	34	5	600	435	BR
3/8"	73212BN3SN00	22	5	300	300	BR
3/8"	7321KBY63200	24	3	300	45	BR

+ Pressure ratings apply to typical coil wattage ratings. See appropriate catalog page for specific power ratings.

* Denotes various coil and enclosure options. Refer to appropriate catalog page.

^ These valves are remote pressure operated, not solenoid operated. Refer to catalog listings for additional information.

Pipe Size NPT	Pressure Vessel Number	Page	Operating Pressure Differential (PSI)			
			Min.	AC+ psi	DC+ psi	Body Mat'l
3/8"	7221GBN3VN00	20	0	230	100	BR
3/8"	73218BN3TN00	22	5	150	150	BR
3/8"	7321KBN3SN00	22	3	150	60	BR
3/8"	7321KBN3SNW0	36	3	150	60	BR
3/8"	72218BN3TN00	20	0	100	40	BR
3/8"	72218RN3TV00	20	0	100	40	SS
3/8"	7121KBN3UV00	15	0	55	20	BR
3/8" Barb	71214LT3QV00	88	0	35	35	N
3/8" Barb	71214LT3SV00	88	0	20	20	N
3/8"	71215SN33N00	16	0	6	5	SS
3/8"	71215SN33NHP	16	0	5-11	0	SS
1/2"	7321HBN4UN00	34	5	600	435	BR
1/2"	73212BN4TN00	22	5	300	300	BR
1/2"	7321KBY6320A	24	3	300	45	BR
1/2"	7221GBN4VN00	20	0	230	100	BR
1/2"	73218BN4UN00	22	5	150	150	BR
1/2"	7321KBN4SN00	22	3	150	60	BR
1/2"	7321KBN4SNW0	36	3	150	60	BR
1/2"	72218BN4UN00	20	0	100	40	BR
1/2"	72218RN4UV00	20	0	100	40	SS
1/2"	7121KBN44V00	15	0	17.5	5	BR
3/4"	73212BN52N00	22	5	300	300	BR
3/4"	7321GBN53N00	22	5	230	230	BR
3/4"	7321GBN53NMC	36	5	230	230	BR
3/4"	7221GBN51N00	20	0	230	100	BR
3/4"	7221GBN51NCO	36	0	230	100	BR
3/4"	73218BN5VN00	22	5	150	150	BR
3/4"	72218BN5VN00	20	0	100	40	BR
3/4"	72218RN5VV00	20	0	100	40	SS
3/4"	XLG2O600	91	5	50	-	BR
1"	73212BN63N00	22	5	300	300	BR
1"	7321GBN64N00	22	5	230	230	BR
1"	7321GBN64NMC	36	5	230	230	BR
1"	7221GBN61N00	20	0	230	100	BR
1"	7221GBN61NCO	36	0	230	100	BR
1"	7221GBN64N00	20	0	230	85	BR
1"	7221GBN64NCO	36	0	230	85	BR
1"	73218BN64N00	22	5	125	125	BR
1"	XLG2O1030	91	5	50	-	BR
1 1/4"	7321GBN76N00	22	5	230	230	BR
1 1/4"	7321GBN76NMC	36	5	230	230	BR
1 1/4"	73218BN75N00	22	5	125	125	BR
1 1/2"	7321GBN88N00	22	5	230	200	BR
1 1/2"	7321GBN88NMC	36	5	230	200	BR
1 1/2"	73218BN87N00	22	5	125	125	BR
1 1/2"	LB27BB8127	44	0	125	-	BR
1 1/2"	XLG2O1530	91	5	50	-	BR
2"	7321GBN99N00	22	5	230	200	BR
2"	7321GBN99NMC	36	5	230	200	BR

+ Pressure ratings apply to typical coil wattage ratings. See appropriate catalog page for specific power ratings.

* Denotes various coil and enclosure options. Refer to appropriate catalog page.

^ These valves are remote pressure operated, not solenoid operated. Refer to catalog listings for additional information.

Pipe Size NPT	Pressure Vessel Number	Page	Operating Pressure Differential (PSI)			
			Min.	AC+ psi	DC+ psi	Body Mat'l
Two-Way Normally Open Valves						
1/8"	71225SN1EF00	18/34	0	750	750	SS
1/8"	7122KBN1GF00	18/33	0	435	435	BR
1/8"	71225SN1GF00	18/33	0	400	400	SS
1/8"	71295SN1ENJ1	18	0	400	400	SS
1/8"	B11DK1400	42	0	400	400	SS
1/8"	71295SN1GNJ1	19	0	325	325	SS
1/8"	3129BBN1AN00	40	0	300	300	BR
1/8"	3129BSN1AN00	40	0	300	300	SS
1/8"	71295SN1KNJ1	19	0	250	250	SS
1/8"	B11DK1200	42	0	200	200	SS
1/8"	3129BBN1EN00	40	0	200	200	BR
1/8"	3129BSN1EN00	40	0	200	200	SS
1/8"	7122KBN1LF00	18	0	175	175	BR
1/8"	71225SN1KF00	18	0	170	170	SS
1/8"	3129BSN1GN00	40	0	150	150	BR
1/8"	3129BSN1GN00	40	0	150	150	SS
1/8"	3129BBN1JN00	40	0	80	80	BR
1/8"	3129BSN1JN00	40	0	80	80	SS
1/8"	B11DK1040	42	0	40	40	SS
1/8"	3129BBN1LN00	40	0	40	40	BR
1/8"	3129BSN1LN00	40	0	40	40	SS
1/4"	71225SN2EF00	18/33	0	750	750	SS
1/4"	7322HBN2SV00	34	5	600	600	BR
1/4"	7122KBN2GF00	18/33	0	435	435	BR
1/4"	71225SN2GF00	18/34	0	400	400	SS
1/4"	71295SN2ENJ1	19	0	400	400	SS
1/4"	71295SN2GNJ1	19	0	325	325	SS
1/4"	71295SN2KNJ1	19	0	250	250	SS
1/4"	73222BN2MN00	25	5	200	200	BR
1/4"	73222SN2MN00	25	5	200	200	SS
1/4"	7122KBN2LF00	18	0	175	175	BR
1/4"	71225SN2KF00	18	0	170	170	SS
3/8"	7322HBN3TN00	34	5	600	600	BR
3/8"	73222BN3SN00	25	5	200	200	BR
3/8"	73228BN3TN00	25	5	150	150	BR
3/8"	72228BN3TV00	21	0	125	125	BR
3/8"	72228RN3TV00	21	0	125	125	SS
1/2"	7322HBN4UN00	34	5	600	600	BR
1/2"	73222BN4TN00	25	5	200	200	BR
1/2"	73228BN4UN00	25	5	150	150	BR
1/2"	72228BN4UV00	21	0	125	125	BR
1/2"	72228RN4UV00	21	0	125	125	SS
3/4"	7322GBN53N00	25	5	230	230	BR
3/4"	7322GBN53NCO	36	5	230	230	BR
3/4"	73222BN52N00	25	5	200	200	BR
3/4"	73228BN5VN00	25	5	150	150	BR
3/4"	72228BN5VV00	21	0	125	125	BR
3/4"	72228RN5VV00	21	0	125	125	SS
1"	7322GBN64N00	25	5	230	230	BR
1"	7322GBN64NCO	36	5	230	230	BR
1"	73222BN63N00	25	5	200	200	BR
1"	73228BN64N00	25	5	125	125	BR
1 1/4"	7322GBN76N00	25	5	230	230	BR
1 1/4"	7322GBN76NCO	36	5	230	230	BR
1 1/4"	73228BN75N00	25	5	125	125	BR
1 1/2"	7322GBN88N00	25	5	170	170	BR
1 1/2"	7322GBN88NCO	36	5	170	170	BR
1 1/2"	73228BN87N00	25	5	125	125	BR
2"	7322GBN99N00	25	5	170	170	BR
2"	7322GBN99NCO	36	5	170	170	BR

Skinner Condensed Valve Listing continued

Pipe Size NPT	Pressure Vessel Number	Page	Operating Pressure Differential (PSI)			
			Min.	AC+ psi	DC+ psi	Body Mat'l
Two-Way External and Remote Pilot Valves						
3/8"	75232BN3SN00	39	0	190	-	BR
3/8"	74232BN3SNJ1	27	0	150	150	BR
1/2"	75232BN4TN00	39	0	190	-	BR
1/2"	74232BN4TNJ1	27	0	150	150	BR
3/4"	75232BN52N00	39	0	190	-	BR
3/4"	74232BN52NJ1	27	0	150	150	BR
1"	75232BN63N00	39	0	190	-	BR
1"	74232BN63NJ1	27	0	150	150	BR
Hot Water and Steam Valves						
Two-Way Normally Closed Valves						
1/4"	7321KBN2RE00	29	3	150	60	BR
1/4"	7121KBN2SE00	28	0	100	40	BR
1/4"	7321KBN2RES0	29	3	45	45	BR
1/4"	7121KBN2SESO	28	0	40	40	BR
3/8"	73218BN3TE00	29	5	150	150	BR
3/8"	7321KBN3SE00	29	3	150	60	BR
3/8"	7221GBN3VE00	28	0	150	100	BR
3/8"	73218BN3TTS0	29	3	125	-	BR
3/8"	72218BN3TE00	28	0	100	40	BR
3/8"	72218RN3TE00	29	0	100	40	SS
3/8"	73218BN3TES0	29	5	50	50	BR
3/8"	72218BN3TES0	28	0	50	-	BR
3/8"	72218RN3TES0	29	0	50	-	SS
3/8"	7321KBN3SESO	29	3	45	45	BR
3/8"	7221GBN3VES0	28	0	45	45	BR
1/2"	73218BN4UE00	29	5	150	150	BR
1/2"	7321KBN4SE00	29	3	150	60	BR
1/2"	7221GBN4VE00	28	0	150	100	BR
1/2"	73218BN4UTS0	29	3	125	-	BR
1/2"	72218BN4UE00	28	0	100	40	BR
1/2"	72218RN4UE00	29	0	100	40	SS
1/2"	73218BN4UES0	29	5	50	50	BR
1/2"	72218BN4UES0	28	0	50	-	BR
1/2"	72218RN4UES0	29	0	50	-	SS
1/2"	7321KBN4SESO	29	3	45	45	BR
1/2"	7221GBN4VES0	28	0	45	45	BR
3/4"	73218BN5VE00	29	5	150	150	BR
3/4"	7221GBN5TE00	28	0	150	100	BR
3/4"	73218BN5VTS0	29	3	125	-	BR
3/4"	72218BN5VE00	28	0	100	40	BR
3/4"	72218RN5VE00	29	0	100	40	SS
3/4"	73218BN5VES0	29	5	50	50	BR
3/4"	72218BN5VES0	28	0	50	-	BR
3/4"	72218RN5VES0	29	0	50	-	SS
3/4"	7221GBN5TES0	28	0	45	45	BR
1"	7221GBN6TE00	28	0	150	100	BR
1"	7221GBN64E00	28	0	150	100	BR
1"	73218BN64E00	29	5	125	125	BR
1"	73218BN64TTS0	29	5	125	-	BR
1"	73218BN64ES0	29	5	50	50	BR
1"	7221GBN6TES0	28	0	45	45	BR
1"	7221GBN64ES0	28	0	45	45	BR
1 1/4"	73218BN75E00	29	5	125	125	BR
1 1/4"	73218BN75TTS0	29	5	125	-	BR
1 1/4"	73218BN75ES0	29	5	50	50	BR
1 1/2"	73218BN87E00	29	5	125	125	BR
1 1/2"	73218BN87TTS0	29	5	125	-	BR
1 1/2"	73218BN87ES0	29	5	50	50	BR

Pipe Size NPT	Pressure Vessel Number	Page	Operating Pressure Differential (PSI)			
			Min.	AC+ psi	DC+ psi	Body Mat'l
Two-Way Normally Open Valves						
3/8"	73228BN3TTS0	30	5	125	-	BR
3/8"	72228BN3TE00	29	0	125	125	BR
3/8"	72228RN3TE00	29	0	125	125	SS
3/8"	72228BN3TES0	29	0	50	-	BR
3/8"	72228RN3TES0	29	0	50	-	SS
1/2"	73228BN4UTS0	30	5	125	-	BR
1/2"	72228BN4UE00	29	0	125	125	BR
1/2"	72228RN4UE00	29	0	125	125	SS
1/2"	72228BN4UES0	29	0	50	-	BR
1/2"	72228RN4UES0	29	0	50	-	SS
3/4"	73228BN52TTS0	30	5	125	-	BR
3/4"	72228BN5VE00	29	0	125	125	BR
3/4"	72228RN5VE00	29	0	125	125	SS
3/4"	72228BN5VES0	29	0	50	-	BR
3/4"	72228RN5VES0	29	0	50	-	SS
1"	73228BN64TTS0	30	5	125	-	BR
1 1/4"	73228BN75TTS0	30	5	125	-	BR
1 1/2"	73228BN87TTS0	30	5	125	-	BR

+ Pressure ratings apply to typical coil wattage ratings. See appropriate catalog page for specific power ratings.
 * Denotes various coil and enclosure options. Refer to appropriate catalog page.
 ^ These valves are remote pressure operated, not solenoid operated. Refer to catalog listings for additional information.

Pipe Size NPT	Pressure Vessel Number	Page	Operating Pressure Differential (PSI)			
			Min.	AC+ psi	DC+ psi	Body Mat'l
Three-Way Hydraulic Valves						
1/8"	A16LB13002	109	0	3000	-	SS
1/8"	A166LB13001	109	0	-	3000	SS
1/8"	71331SN1MM00	94	0	1000	1000	SS
1/8"	A13LB13002	109	0	3000	-	SS
1/8"	A136LB13001	109	0	-	3000	SS
1/8"	A15LB13002	109	0	3000	-	SS
1/8"	A156LB13001	109	0	-	3000	SS

Pipe Size NPT	Pressure Vessel Number	Page	Operating Pressure Differential (PSI)			
			Min.	AC+ psi	DC+ psi	Body Mat'l
Three-Way Directional Control Valves						
1/8"	B16DK1250	67	0	250	250	SS
1/8"	71385SN1GNJ1	52	0	235	235	SS
1/8"	3138BBN1AN00	65	0	230	230	BR
1/8"	3138BSN1AN00	65	0	230	230	SS
1/8"	B16DK1200	67	0	200	200	SS
1/8"	B16DK1175	67	0	175	175	SS
1/8"	3138BBN1EN00	65	0	160	160	BR
1/8"	3138BSN1EN00	65	0	160	160	SS
1/8"	3138BSA6EN00	65	0	160	160	SS
1/8"	71385SN1KNJ1	52	0	140	140	SS
1/8"	71385SN1MNJ1	52	0	125	125	SS
1/8"	3138BBN1GN00	65	0	120	120	BR
1/8"	3138BSN1GN00	65	0	120	120	SS
1/8"	3138BSA6GN00	65	0	120	120	SS
1/8"	3138BBN1JN00	65	0	80	80	BR
1/8"	3138BSN1JN00	65	0	80	80	SS
1/8"	3138BBN1LN00	65	0	60	60	BR
1/8"	3138BSN1LN00	65	0	60	60	SS
1/8"	B16DK1050	67	0	50	50	SS
1/8"	3138BBN1NN00	65	0	35	35	BR
1/8"	3138BSN1NN00	65	0	35	35	SS
1/8"	3138BSA6NN00	65	0	35	35	SS
1/8"	3138BBN1QN00	65	0	20	20	BR
1/8"	3138BSN1QN00	65	0	20	20	SS
1/8"	3138BSA6QN00	65	0	20	20	SS
1/4"	A66LB2251	72	0	-	250	zinc
1/4"	A66LB2176	72	0	-	175	zinc
1/4"	A66LB2126	72	0	-	125	zinc
1/4"	A6LB2252	72	0	250	-	zinc
1/4"	71385SN2GNJ1	52	0	235	235	SS
1/4"	A6LB2177	72	0	175	-	zinc
1/4"	71385SN2KNJ1	52	0	140	140	SS
1/4"	71385SN2MNJ1	52	0	125	125	SS
1/4"	A6LB2127	72	0	125	-	zinc
3/8"	73382BN3RNJ1	56	10	180	180	BR
1/2"	73382BN4UNJ1	56	10	180	180	BR
3/4"	73382BN52NJ1	56	10	180	180	BR

Three-Way MultiPurpose Valves						
#10-32	MBD002	110	0	150	150	P
Flange	7133FBF4LVJ1	50	0	60	60	BR
1/8"	71335SN1ANJ1	51	0	400	400	SS
1/8"	71335SN1ENJ1	51	0	180	180	SS
1/8"	7133KBN1GVJ1	50	0	150	150	BR
1/8"	C4*1150	69	0	150	150	BR
1/8"	3133BBN1AN00	64	0	150	150	BR

Pipe Size NPT	Pressure Vessel Number	Page	Operating Pressure Differential (PSI)			
			Min.	AC+ psi	DC+ psi	Body Mat'l
1/8"	3133BSN1AN00	64	0	150	150	SS
1/8"	B14DK1150	67	0	150	150	SS
1/8"	71335SN1GNJ1	51	0	115	115	SS
1/8"	7133KBN1JVJ1	50	0	100	100	BR
1/8"	3133BBN1EN00	64	0	100	100	BR
1/8"	3133BSN1EN00	64	0	100	100	SS
1/8"	3133BSA6EN00	65	0	100	100	SS
1/8"	B14DK1100	67	0	100	100	SS
1/8"	71335SN1KNJ1	51	0	80	80	SS
1/8"	3133BBN1GN00	64	0	80	80	BR
1/8"	3133BSN1GN00	64	0	80	80	SS
1/8"	3133BSA6GN00	65	0	80	80	SS
1/8"	C4*1075	69	0	75	75	BR
1/8"	B14DK1075	67	0	75	75	SS
1/8"	7133KBN1LVJ1	50	0	60	60	BR
1/8"	3133BBN1JN00	64	0	60	60	BR
1/8"	3133BSN1JN00	64	0	60	60	SS
1/8"	C4*1052	69	0	50	-	BR
1/8"	3133BBN1LN00	64	0	35	35	BR
1/8"	3133BSN1LN00	64	0	35	35	SS
1/8"	B14DK1030	67	0	30	30	SS
1/8"	C4*1031	69	0	-	30	BR
1/8"	3133BBN1NN00	64	0	20	20	BR
1/8"	3133BSN1NN00	64	0	20	20	SS
1/8"	3133BSA6NN00	65	0	20	20	SS
1/8"	3133BBN1QN00	64	0	10	10	BR
1/8"	3133BSN1QN00	64	0	10	10	SS
1/8"	3133BSA6QN00	65	0	10	10	SS
1/4"	7133KBN2BVJ1	50	0	435	435	BR
1/4"	71335SN2ANJ1	51	0	400	400	SS
1/4"	71335SN2ENJ1	51	0	180	180	SS
1/4"	7133KBN2GVJ1	50	0	150	150	BR
1/4"	7133TVN2GV00	51	0	150	150	SS
1/4"	A4LB2152	71	0	150	-	zinc
1/4"	A46LB2151	71	0	-	150	zinc
1/4"	71335SN2GNJ1	51	0	115	115	SS
1/4"	7133KBN2JVJ1	50	0	100	100	BR
1/4"	7133TBN2JV00	50	0	100	100	BR
1/4"	7133TVN2JV00	51	0	100	100	SS
1/4"	A4LB2102	71	0	100	-	zinc
1/4"	A46LB2101	71	0	-	100	zinc
1/4"	71335SN2KNJ1	51	0	80	80	SS
1/4"	A4LB2077	71	0	75	-	zinc
1/4"	A46LB2076	71	0	-	75	zinc
1/4"	7133KBN2LVJ1	50	0	60	60	BR
1/4"	7133TBN2LV00	50	0	60	60	BR
1/4"	7133TVN2LV00	52	0	60	60	SS
1/4"	7133TBN2NV00	50	0	30	30	BR
1/4"	7133TVN2NV00	51	0	30	30	SS

Three-Way Normally Closed Valves						
Flange	7131FBF4LV00	47	0	100	100	BR
1/8"	71315SN1EN00	47	0	250	250	SS
1/8"	71315SN1ENJ1	47	0	250	250	SS
1/8"	7131KBN1GV00	47	0	215	215	BR
1/8"	71315SN1GN00	47	0	200	200	SS
1/8"	71315SN1GNJ1	47	0	200	200	SS
1/8"	3131BBN1AN00	64	0	200	200	BR

+ Pressure ratings apply to typical coil wattage ratings. See appropriate catalog page for specific power ratings.

* Denotes various coil and enclosure options. Refer to appropriate catalog page.

^ These valves are remote pressure operated, not solenoid operated. Refer to catalog listings for additional information.

Skinner Condensed Valve Listing continued

Pipe Size NPT	Pressure Vessel Number	Page	Operating Pressure Differential (PSI)			
			Min.	AC+ psi	DC+ psi	Body Mat'l
1/8"	3131BSN1AN00	64	0	200	200	SS
1/8"	B13DK1200	67	0	200	200	SS
1/8"	B13ADK1200	67	0	200	200	SS
1/8"	C3*1175	69	0	175	175	BR
1/8"	C3A*1175	69	0	175	175	BR
1/8"	3131BBN1EN00	64	0	150	150	BR
1/8"	3131BSN1EN00	64	0	150	150	SS
1/8"	3131BSA6EN00	65	0	150	150	SS
1/8"	B13DK1150	67	0	150	150	SS
1/8"	B13ADK1150	67	0	150	150	SS
1/8"	71315SN1KN00	47	0	125	125	SS
1/8"	71315SN1KNJ1	47	0	125	125	SS
1/8"	C3*1125	69	0	125	125	BR
1/8"	C3A*1125	69	0	125	125	BR
1/8"	7131KBN1LV00	46	0	100	100	BR
1/8"	3131BBN1GN00	64	0	100	100	BR
1/8"	3131BSN1GN00	64	0	100	100	SS
1/8"	3131BSA6GN00	65	0	100	100	SS
1/8"	B13DK1100	67	0	100	100	SS
1/8"	B13ADK1100	67	0	100	100	SS
1/8"	71315SN1MN00	46	0	90	90	SS
1/8"	71315SN1MNJ1	46	0	90	90	SS
1/8"	3131BBN1JN00	64	0	80	80	BR
1/8"	3131BSN1JN00	64	0	80	80	SS
1/8"	C3*1075	69	0	75	75	BR
1/8"	C3A*1075	69	0	75	75	BR
1/8"	3131BBN1LN00	64	0	60	60	BR
1/8"	3131BSN1LN00	64	0	60	60	SS
1/8"	C3*1050	69	0	50	50	BR
1/8"	C3A*1050	69	0	50	50	BR
1/8"	3131BBN1NN00	64	0	40	40	BR
1/8"	3131BSN1NN00	64	0	40	40	SS
1/8"	3131BSA6NN00	65	0	40	40	SS
1/8"	B13DK1040	67	0	40	40	SS
1/8"	B13ADK1040	67	0	40	40	SS
1/8"	71315SN1SN00	46	0	25	25	SS
1/8"	71315SN1SNJ1	46	0	25	25	SS
1/8"	3131BBN1QN00	64	0	10	10	BR
1/8"	3131BSN1QN00	64	0	10	10	SS
1/8"	3131BSA6QN00	65	0	10	10	SS
1/8"	71315SN1VNJ1	46	0	VAC	VAC	SS
1/4"	7131KBN2BR00	59	0	1100	1100	BR
1/4"	7131KBN2BF00	59	0	580	580	BR
1/4"	7131KBN2ER00	59	0	435	435	BR
1/4"	71313SN2EN00	58	0	250	250	SS
1/4"	71313SN2ENJ1	58	0	250	250	SS
1/4"	71315SN2EN00	46	0	250	250	SS
1/4"	71315SN2ENJ1	46	0	250	250	SS
1/4"	A3LB2252	71	0	250	-	zinc
1/4"	A36LB2251	71	0	-	250	zinc
1/4"	7131KBN2GV00	46	0	215	215	BR
1/4"	71313SN2GN00	58	0	200	200	S
1/4"	71313SN2GNJ1	58	0	200	200	SS
1/4"	71315SN2GN00	46	0	200	200	SS
1/4"	71315SN2GNJ1	46	0	200	200	SS
1/4"	7131TVN2GV00	46	0	200	200	SS
1/4"	A3LB2177	71	0	175	-	zinc

Pipe Size NPT	Pressure Vessel Number	Page	Operating Pressure Differential (PSI)			
			Min.	AC+ psi	DC+ psi	Body Mat'l
1/4"	A36LB2176	71	0	-	175	zinc
1/4"	7131KBN2JV00	46	0	150	150	BR
1/4"	7131TBN2JV00	46	0	150	150	BR
1/4"	7131TVN2JV00	46	0	150	150	SS
1/4"	71313SN2KN00	58	0	125	125	SS
1/4"	71313SN2KNJ1	58	0	125	125	SS
1/4"	71315SN2KN00	47	0	125	125	SS
1/4"	71315SN2KNJ1	47	0	125	125	SS
1/4"	A3LB2127	71	0	125	-	zinc
1/4"	A36LB2126	71	0	-	125	zinc
1/4"	7131TBN2LV00	47	0	110	110	BR
1/4"	7131TVN2LV00	47	0	110	110	SS
1/4"	7131EBN2LN00	58	0	100	100	BR
1/4"	7131KBN2LV00	46	0	100	100	BR
1/4"	71313SN2MN00	58	0	90	90	SS
1/4"	71313SN2MNJ1	58	0	90	90	SS
1/4"	71315SN2MN00	47	0	90	90	SS
1/4"	71315SN2MNJ1	47	0	90	90	SS
1/4"	7131TVN2NV00	47	0	70	70	SS
1/4"	7131TBN2RV00	46	0	30	30	BR
1/4"	71315SN2SN00	47	0	25	25	SS
1/4"	71315SN2SNJ1	47	0	25	25	SS
1/4"	71315SN2VNJ1	47	0	VAC	VAC	SS
3/8"	73312BN3RNJ0	53	10	180	180	BR
3/8"	73312BN3RNJ1	53	10	180	180	BR
1/2"	73312BN4UNJ0	53	10	180	180	BR
1/2"	73312BN4UNJ1	53	10	180	180	BR
3/4"	73312BN52NJ0	53	10	180	180	BR
3/4"	73312BN52NJ1	53	10	180	180	BR
Three-Way Normally Open Valves						
1/8"	71395SN1ENJ1	49	0	250	250	SS
1/8"	B15DK1200	67	0	200	200	SS
1/8"	C5*1175	69	0	175	175	BR
1/8"	3139BBN1AN00	64	0	160	160	BR
1/8"	3139BSN1AN00	64	0	160	160	SS
1/8"	71395SN1GNJ1	49	0	150	150	SS
1/8"	B15DK1150	67	0	150	150	SS
1/8"	71395SN1KNJ1	49	0	125	125	SS
1/8"	3139BBN1EN00	64	0	125	125	BR
1/8"	3139BSN1EN00	64	0	125	125	SS
1/8"	3139BSA6EN00	65	0	125	125	SS
1/8"	B15DK1125	67	0	125	125	SS
1/8"	C5*1100	69	0	100	100	BR
1/8"	3139BBN1GN00	64	0	100	100	BR
1/8"	3139BSN1GN00	64	0	100	100	SS
1/8"	3139BSA6GN00	65	0	100	100	SS
1/8"	3139BBN1JN00	64	0	80	80	BR
1/8"	3139BSN1JN00	64	0	80	80	SS
1/8"	C5*1060	69	0	60	60	BR
1/8"	3139BBN1LN00	64	0	60	60	BR
1/8"	3139BSN1LN00	64	0	60	60	SS
1/8"	3139BBN1NN00	64	0	40	40	BR
1/8"	3139BSN1NN00	64	0	40	40	SS
1/8"	3139BSA6NN00	65	0	40	40	SS
1/8"	B15DK1040	67	0	40	40	SS
1/8"	3139BBN1QN00	64	0	10	10	BR
1/8"	3139BSN1QN00	64	0	10	10	SS

+ Pressure ratings apply to typical coil wattage ratings. See appropriate catalog page for specific power ratings.

* Denotes various coil and enclosure options. Refer to appropriate catalog page.

^ These valves are remote pressure operated, not solenoid operated. Refer to catalog listings for additional information.

Pipe Size NPT	Pressure Vessel Number	Page	Operating Pressure Differential (PSI)			
			Min.	AC+ psi	DC+ psi	Body Mat'l
1/8"	3139BBN1NN00	64	0	40	40	BR
1/8"	3139BSN1NN00	64	0	40	40	SS
1/8"	3139BSA6NN00	65	0	40	40	SS
1/8"	B15DK1040	67	0	40	40	SS
1/8"	3139BBN1QN00	64	0	10	10	BR
1/8"	3139BSN1QN00	64	0	10	10	SS
1/8"	3139BSA6QN00	65	0	10	10	SS
1/4"	71395SN2ENJ1	49	0	250	250	SS
1/4"	A5LB2252	71	0	250	-	zinc
1/4"	A56LB2251	71	0	-	250	zinc
1/4"	A5LB2177	71	0	175	-	zinc
1/4"	A56LB2176	71	0	-	175	zinc
1/4"	7132TBN2NV00	49	0	150	-	BR
1/4"	71395SN2GNJ1	49	0	150	150	SS
1/4"	71395SN2KNJ1	49	0	125	125	SS
1/4"	A5LB2127	71	0	125	-	zinc
1/4"	A56LB2126	71	0	-	125	zinc
3/8"	73322BN3RNJ0	55	10	180	180	BR
3/8"	73322BN3RNJ1	55	10	180	180	BR
1/2"	73322BN4UNJ0	55	10	180	180	BR
1/2"	73322BN4UNJ1	55	10	180	180	BR
3/4"	73322BN52NJ0	55	10	180	180	BR
3/4"	73322BN52NJ1	55	10	180	180	BR

Three-Way External and Remote Pilot Valves

3/8"	75332BN3RN00	63	0	180	-	BR
3/8"	74332BN3RNJ1	57	0	170	170	BR
1/2"	75332BN4UN00	63	0	180	-	BR
1/2"	74332BN4UNJ1	57	0	170	170	BR
3/4"	75332BN52N00	63	0	180	-	BR
3/4"	74332BN52NJ1	57	0	170	170	BR

Pipe Size NPT	Pressure Vessel Number	Page	Operating Pressure Differential (PSI)			
			Min.	AC+ psi	DC+ psi	Body Mat'l
Four-Way Valves						
1/8"	7341LAN1HNMO	76	15	150	150	ALUM
1/4"	76419AN2NNCB	78	0	150	150	ALUM
1/4"	76429AN2NN00	78	0	150	150	ALUM
1/4"	76469AN2NN00	78	0	150	150	ALUM
1/4"	73419AN2NN00	77	15	150	150	ALUM
1/4"	73419AN2NNMO	77	15	150	150	ALUM
1/4"	7341LMN2NNMO	76	15	150	150	ZINC
1/4"	73417BN2KN00	79	30	150	150	BR
1/4"	73477BN2KN00	79	30	150	150	BR
1/4"	73417BN2PN00	79	30	150	150	BR
1/4"	73477BN2PN00	79	30	150	150	BR
1/4"	73417VN2KN00	79	30	150	150	SS
1/4"	73417VN2PN00	79	30	150	150	SS
1/4"	73477VN2KN00	79	30	150	150	SS
1/4"	73477VN2PN00	79	30	150	150	SS
1/4"	75419AN2NN00	77	^	150	150	ALUM
1/4"	V933L**2150	83	0	150	150	ZINC
1/4"	V935L**2150	83-84	0	150	150	ZINC
1/4"	V955L**2150	83-84	0	150	150	ZINC
1/4"	71417BN2SN00	74	0	125	-	BR
3/8"	71417BN3SN00	74	0	125	-	BR
1/4"	71477BN2SN00	74	0	125	-	BR
3/8"	71477BN3SN00	74	0	125	-	BR

Pipe Size NPT	Pressure Vessel Number	Page	Operating Pressure Differential (PSI)			
			Min.	AC+ psi	DC+ psi	Body Mat'l
1/4"	V933L**2100	83	0	100	100	ZINC
1/4"	V935L**2100	83-84	0	100	100	ZINC
1/4"	V955L**2100	83-84	0	100	100	ZINC
1/4"	V933L**2075	83	0	75	75	ZINC
1/4"	V933L**2050	83	0	50	50	ZINC
1/4"	V935L**2050	83-84	0	50	50	ZINC
1/2"	73417BN4UN00	79	30	150	150	BR
1/2"	73477BN4UN00	79	30	150	150	BR

Pipe Size NPT	Pressure Vessel Number	Page	Operating Pressure Differential (PSI)			
			Min.	AC+ psi	DC+ psi	Body Mat'l

Intrinsically Safe Valves

Two-Way Normally Closed Valves

1/4"	U121K0490	95	0	-	150	BR
1/4"	U121K0890	95	0	-	100	BR
1/4"	U121K0690	95	0	-	75	BR
1/2"	U321H1590	95	5	-	150	BR
3/4"	U321G3690	95	5	-	150	BR
1"	U321G3790	95	5	-	150	BR
1 1/4"	U321G3890	95	5	-	150	BR
1 1/2"	U321G3990	95	5	-	150	BR
2"	U321G4090	95	5	-	150	BR

Three-Way Normally Closed Valves

Flange	U131F4490	97	0	-	150	BR
Flange	U131F4890	97	0	-	100	BR
Flange	U131F4690	97	0	-	75	BR
1/4"	U131K0490	97	0	-	150	BR
1/4"	U131K0890	97	0	-	100	BR
1/4"	U131K0690	97	0	-	75	BR
1/4"	U131V5490	97	0	-	150	SS
1/4"	U131V5890	97	0	-	100	SS
1/4"	U131V5690	97	0	-	75	SS
1/4"	U331B7490	97	15	-	150	Alum
1/4"	U131E0391	99	1.5	-	105	BR
1/4"	U133X5196	97	0	-	150	SS
1/2"	U331L2190	97	7	-	150	Alum

Three-Way Universal Valves

1/4"	U133X5196	97	0	-	150	SS
1/4"	U033X5156	62/99	0	-	150	SS

Four-Way Valves

1/4"	U341B3490	100	15	-	150	Alum
1/4"	U347L1190	100	15	-	150	Zinc
1/2"	U341L2190	100	7	-	150	Alum
1"	U341L4190	100	15	-	150	Alum

+ Pressure ratings apply to typical coil wattage ratings. See appropriate catalog page for specific power ratings.

* Denotes various coil and enclosure options. Refer to appropriate catalog page.

^ These valves are remote pressure operated, not solenoid operated. Refer to catalog listings for additional information.

Skinner Condensed Valve Listing continued

Pipe Size NPT	Pressure Vessel Number	Page	Operating Pressure Differential (PSI)			
			Min.	AC+ psi	DC+ psi	Body Mat'l
Manual Reset Valves						
Two-Way Normally Closed Valves						
1/4"	70215SN2KVVR	38	0	150	150	SS
1/4"	70215SN2KVET	38	0	150	150	SS
1/2"	70218BN4UNVR	38	5	150	150	BR
1/2"	70218BN4UNET	38	5	150	150	BR
3/4"	70212BN52NVR	38	5	300	300	BR
3/4"	70212BN52NET	38	5	300	300	BR
1"	70218BN64NVR	38	5	125	125	BR
1"	70218BN64NET	38	5	125	125	BR
1 1/4"	70218BN75NVR	38	5	125	125	BR
1 1/4"	70218BN75NET	38	5	125	125	BR
1 1/2"	70218BN87NVR	38	5	125	125	BR
1 1/2"	70218BN87NET	38	5	125	125	BR
Two-Way Normally Open Valves						
3/4"	70222BN52NVR	38	5	300	300	BR
3/4"	70222BN52NET	38	5	300	300	BR
1"	70228BN64NVR	38	5	125	125	BR
1"	70228BN64NET	38	5	125	125	BR
1 1/4"	70228BN75NVR	38	5	125	125	BR
1 1/4"	70228BN75NET	38	5	125	125	BR
1 1/2"	70228BN87NVR	38	5	125	125	BR
1 1/2"	70228BN87NET	38	5	125	125	BR
Three-Way Normally Closed Valves						
1/4"	70315SN2ENVR	61	0	200	200	SS
1/4"	70315SN2ENET	61	0	200	200	SS
1/4"	70315SN2GVVR	61	0	150	150	SS
1/4"	70315SN2GVET	61	0	150	150	SS
1/4"	70315SN2KVVR	61	0	90	90	SS
1/4"	70315SN2KVET	61	0	90	90	SS
1/4"	70315SN2MNVVR	61	0	60	60	SS
1/4"	70315SN2MNET	61	0	60	60	SS
3/8"	70312BN3RNVR	61	10	180	180	BR
3/8"	70312BN3RNET	61	10	180	180	BR
1/2"	70312BN4UNVR	61	10	180	180	BR
1/2"	70312BN4UNET	61	10	180	180	BR
3/4"	70312BN52NVR	61	10	180	180	BR
3/4"	70312BN52NET	61	10	180	180	BR
Three-Way Normally Open Valves						
1/4"	70325SN2GNVR	61	0	150	150	SS
1/4"	70325SN2GNET	61	0	150	150	SS
3/8"	70322BN3RNVR	61	10	180	180	BR
3/8"	70322BN3RNET	61	10	180	180	BR
1/2"	70322BN4UNVR	61	10	180	180	BR
1/2"	70322BN4UNET	61	10	180	180	BR
3/4"	70322BN52NVR	61	10	180	180	BR
3/4"	70322BN52NET	61	10	180	180	BR
Three-Way Universal Valves						
1/4"	7033TVN2GVVR	62	0	150	150	SS
1/4"	7033TVN2GVET	62	0	150	150	SS
1/4"	U033X5156	62/99	0	145	145	SS
1/4"	7033TBN2JVVR	61	0	100	100	BR
1/4"	7033TBN2JVET	61	0	100	100	BR
1/4"	7033TVN2JVVR	62	0	100	100	SS
1/4"	7033TVN2JVET	62	0	100	100	SS
1/4"	7033TBN2NVVR	61	0	50	50	BR
1/4"	7033TBN2NVET	61	0	50	50	BR
1/4"	7033TVN2NVVR	62	0	50	50	SS
1/4"	7033TVN2NVET	62	0	50	50	SS

+ Pressure ratings apply to typical coil wattage ratings. See appropriate catalog page for specific power ratings.

Ordering Information

7000 SERIES

The 7000 Series product line uses a significant numbering system that allows every user an easy method to select, identify and understand the product being purchased. Each of the 20 characters denote a specific feature. The

complete number provides a description of the valve configuration.

There are 6 different product categories that can be ordered. These product categories are:

Item	Description
1	Fully assembled valves with integrated coils
2	Fully assembled valves with conventional coils and enclosures
3	Pressure Vessels only
4	Integrated Coils only
5	Coil/Enclosure Assemblies
6	Accessories

Ordering Items 1 and 2, Fully Assembled Valves

Step 1: Select the Pressure Vessel catalog number based on the application requirements. The catalog number is specified in the individual catalog sections.

Step 2: Use the Mechanical Options Table, if required, to write the option code in place of the last two pressure vessel digits "00". See page 121.

Step 3: Select the appropriate integrated coil, and enter (N0 = nut and washer) in the 13th and 14th digit, or enclosure and conventional coil. See page 120 and 121.

Step 4: Use the Electrical Options Table, if required, to write the option code in place of the last two digits. See page 121.

Step 5: Use the Voltage Code to specify the correct voltage for the valve.

Pressure Vessel	Enclosure	Coil	Voltage Code
7121KBN2NV00	+ N0	+ C111	+ P3
7121KBN2NV00N0C111P3			
71215SN2VV00	+ N0	+ H222	+ C2
71215SN2VV00N0H222P3			

Ordering Items 3 and 4, Pressure Vessels, Integrated Coils

Pressure Vessels can be ordered as separate items. Simply select the catalog number and submit the order. If a mechanical option is desired, make sure that it is included in place of the last two "00" digits in the pressure vessel number.

Integrated Coils can also be ordered as separate items. Simply select the coil number and add the correct voltage code. If an electrical option is desired, make sure that it is included in place of the last two digits in the coil number, then specify the voltage by its code.

Example: Select integrated coil "C111" for a 120/60-110/50 voltage, the number to order this coil then becomes "C111P3".

Ordering Item 5, Coil/Enclosure Assemblies

Step 1: Select the appropriate enclosure

Step 2: Select the appropriate coil.

Step 3: Determine the correct voltage code.

Enclosure	Coil	Voltage Code
A0	+	J111
	+	C2
A0J111C2 = Standard enclosure, molded Class F coil, 24VDC		

Ordering Item 6, Accessories

Accessories can be purchased by simply specifying the part number with the accessories. If an enclosure or electrical option is being purchased as a separate item (as an accessory on page 121) select the option number and place the order.

Example: To buy a 1/2" conduit DIN plug (electrical option code D2) as a separate accessory simply order "ELECD2".

Ordering Products Not Listed in the Catalog

When an application demands a combination of features not listed in the catalog, use the option offered in the current price book to specify the exact valve needed. Fluid Control Division personnel will then assist in determining the availability and price of the new product.

Example: A 71215SN2GN00 with EPDM seal material can be requested by asking for a 71215SN2GE00. In this example the N (for nitrile) was substituted with an E (for EPDM) in the valve number.

If an application requires a combination of options not listed in the catalog, contact the Fluid Control Division Customer Response Center at 860-827-2300 for a valve number, pricing, and order quantity minimums, if any.

3000 SERIES

The 3000 Series product line uses a significant numbering system to specify a particular valve. Each of the 20 characters or combination of characters denotes a specific feature or valve configuration. To order a 3000 Series valve, specify the full 20 digit number using the codes in the chart on page 126.

The first 12 digits designate the

configuration of the Pressure Vessel, the next two digits (13th and 14th) designate the enclosure, and the last 6 digits (15th through 20th) designate the coil. Please note that the voltage is indicated by the last two digits of the coil and valve number.

The 12 digit pressure vessel number is listed in the 3000 Series catalog section.

Also note that not all combinations of materials or constructions are possible. If an application requires combinations of options not listed in the catalog, contact the Fluid Control Division Customer Response Center at 860 827-2300 for a valve number and pricing.

A, B, C, AND V9 SERIES VALVES

Ordering Standard Catalog Valves:

Example:

- 1) Specify the valve catalog number-B2DA1250
- 2) Specify the required voltage-120V, 60Hz

INTRINSICALLY SAFE VALVE ORDERING INFORMATION

Skinner Valve's Intrinsically Safe solenoid valves are available with a variety of coils and enclosures. Valve part numbers ending with 90 accept the following FM-approved coil numbers:

490885
490890
490895
490880
490860

Those valve part numbers ending with 91 and 96 only accept coil numbers:

490860
482660
483330.01

To Order a Complete Valve

Step 1: Select the base valve which meets the application requirements from pages 95 through 100.

Step 2: Select the desired coil/enclosure combination from pages 102 through 106.

Step 3: Delete the first two digits of the coil part number (either 48 or 49).

Step 4: Add the remaining four digits of the coil part number to the end of the base valve number.

Step 5: All the I.S. coils are designed for 24VDC (nominal) service. Add the voltage code N7.

Example: An application requires a 1/4" NPTF, 3-way normally closed valve for instrument air flow at 1 SCFM. Brass is a suitable body material. The customer would like a splice box style coil enclosure.

- 1) Select the base valve. In this case: U131K0490.
- 2) Select the desired coil/enclosure combination. In this case: 490885

- 3) Delete the first two digits 49 to create the coil/enclosure suffix 0885.
- 4) Add coil number as a suffix to base valve number: U131K04900885.
- 5) Finally, add the voltage code N7 (24VDC nominal only): U131K04900885N7.

IS Coil Designs

Skinner's Intrinsically Safe valve offering contains a variety of coil designs. The five different coil styles allow the project engineer to select the optimum coil configuration for the application.

The Splice Box Coil contains a small compartment in which to make the electrical terminations, eliminating the need for a separate junction box. Our Potted Lead Wire Coil has a metal enclosure for maximum environmental protection and integral strain relief on the two meter cable.

Two coils with DIN-style spade terminations are also available. The Potted Coil with DIN connection has a metal enclosure for added protection, while the 32mm DIN Coil is our

most compact coil style. The 32mm DIN is ideal for installations with space limitations or for use on our multi-station manifold assemblies.

Finally, the Booster Circuit Coil is used on many of our special purpose valve designs. By generating a brief burst of power, the Booster Circuit Coil can operate our Quick Exhaust valve and high-flow direct operated models.

All five intrinsically safe coil designs are built to meet NEMA 4 Watertight construction, and are approved for T6 temperature classification to address the most demanding applications. If the use of electrical conduit is preferred, 1/2" NPT conduit hub adaptors may be ordered for field installation.







Sleeve Exhaust Adaptor

To facilitate pipe connections to the I.S. valve operator (3-way), a sleeve exhaust adaptor may be ordered separately for field installation. The adaptor, U21-004, contains G 1/8 female (BSP) and 1/4" NPT female threads.

Coil Information

7000 SERIES COILS



Integrated Coil Offering (These coils utilize enclosure code "N0". For coil dimensions, see page 125.)

Coil Code	Type of Termination	Wattage	Description
	L111	Leads	Class F Molded with 18" leads
	L222	Leads	Class H Molded with 18" leads
	L322	Leads	Class H Molded with 18" leads
	C111	1/2" Conduit	Class F Molded, NEMA 1, 2, 3, 3s, 4, 4X, 18" leads
	C222	1/2" Conduit	Class H Molded, NEMA 1, 2, 3, 3s, 4, 4X, 18" leads
	C322	1/2" Conduit	Class H Molded, NEMA 1, 2, 3, 3s, 4, 4X, 18" leads
	H111	1/2" Conduit	Class F Molded, NEMA 3, 3s, 4, 4X, 7, 9 18" leads
	H222	1/2" Conduit	Class H Molded, NEMA 3, 3s, 4, 4X, 7, 9 18" leads
	H322	1/2" Conduit	Class H Molded, NEMA 3, 3s, 4, 4X, 7, 9 18" leads
	H2S1	1/2" Conduit Stainless	Class H Molded, NEMA 3, 3s, 4, 4X, 7, 9 18" leads, stainless steel
	D100	DIN	Class F Molded
	D200	DIN	Class H Molded
	D300	DIN	Class H Molded
	S100	Screw	Class F Molded
	S200	Screw	Class H Molded
	S300	Screw	Class H Molded
	T100	1/4" Tab	Class F Molded

Conventional Coil Offering (These coils require conventional coil enclosures-see page 120.)

	J111	Leads	Class F Molded with 18" leads
	J222	Leads	Class H Molded with 18" leads
	J322	Leads	Class H Molded with 18" leads

Specialty Coils (These coils require conventional coil enclosures-see page 134.)

	J611	18" Leads	1.3	Fluxtron 2 wire, low power, low temperature
	F611	18" Leads	1.1	Fluxtron 4 wire, low power, low temperature (TTL logic level compatible)
	J011	18" Leads	0	Magnetlatch 2 wire, DC only
	G011	18" Leads	0	Magnetlatch 3 wire, AC or DC (pulse)

Notes:

- * For coil temperature information, refer to Technical Information section beginning on page 114.
- * Refer to 7000 Series numbering system description beginning on page 119 for voltage code designations.
- * Ordinary Location Agency: Underwriter's Laboratories Inc. (UL), Ordinary Location File Number MH 15507/ Canadian Standards Association (CSA), Ordinary Location File Number LR 10716
- * Hazardous location coils certified for Class I, Division 1 and 2, Groups A,B,C,D; Class II, Division 1 and 2, Groups E,F,G. Agency File Numbers: Underwriter's Laboratories Inc. (UL), Hazardous Location File Number E 23267/ Canadian Standards Association (CSA), Hazardous Location File Number LR 16286
- * DIN terminations per DIN 43650A/ ISO 4400 requirements.

- * Valves with AC Fluxtron coils receive a 10 watt pressure rating. Valves with a DC Fluxtron coil receive a DC pressure rating.
- * **Fluxtron coils are not available for direct lift valves (code 2 in position 2) or for steam service valves (code S0 in position 11,12 of the pressure vessel)**
- * Magnetlatch coils are equipped with permanent magnets to retain plunger position after power is removed.
- * Magnetlatch coils receive the same pressure ratings as a valve with a 10 watt coil.
- * Magnetlatch coils are not available for steam service valves (S0 in position 11,12 of the pressure vessel)
- * Magnetlatch coils use minimal average power and have no appreciable temperature rise.

Available Voltages

Standard available voltages are listed here. Additional voltages can be satisfied with a new coil of a specific voltage. Consult Fluid Control Division.

Note: Valves encoded with 4th digit = 2 (i.e. 7122, 7222, 7322, except for 71221 and 73222) do not meet UL temperature approval requirements on 50Hz voltages when supplied with 10 watt or 22 watt dual frequency coils listed here. Consult Fluid Control Division if

UL approval is required. However, the following voltages and codes can be specified for operating these valves on 60Hz:

120/60	B6
240/60	B8
480/60	1B

Integrated, Conventional and Magnelatch Coil Voltages

DC Voltage	Voltage Code	Agency Approval
12 VDC	C1	Yes
24 VDC	C2	Yes
48 VDC	C4	Yes
120 VDC	C6	Yes

AC Voltage	Voltage Code	Agency Approval
24/60	B2	Yes
110/50, 120/60	P3	Yes
208/60 ¹	2K	Yes
220/50, 240/60	Q3	Yes
440/50, 480/60*	Q8	Yes

Fluxtron Coil Voltages





Voltage	Voltage Code	Agency Approval
12 VDC	C1	Yes
24 VDC	C2	Yes
24-50/60 AC	P0	Yes
110/50, 120/60 AC	2W	Yes

* Note: Not available in coil types H111, H222, H322

¹ Not available in magnelatch

Voltage range -15% to +10% for continuous duty.

ATEX 94/9/EC Compliant Coils







Coil Code	Type of Termination	Wattage	Protection/ Temperature Class Marking	Description	Certificate of Conformity
 HZ09	3-wire cable gland	10	EEx d II C T4/T5 CE 0081 Ex II 2 G/D	Molded Class F, internal and external grounding Cable length: 3 meters IP65	LCIE 02 ATEX 6009 X
 HZ10	3-wire cable gland	10	EEx m II T4/T5 CE 0344 Ex II 2 G/D	Molded Class H, internal and external grounding Cable length: 3 meters IP65	LCIE 02 ATEX 6020 X
 HZ11	3-wire cable gland	22	EEx m II T4/T5 CE 0344 Ex II 2 G/D	Molded Class H, internal and external grounding Cable length: 3 meters IP65	LCIE 02 ATEX 6020 X
 492190(VZ03)	cable connection		EEx me II T3/T4 CE 0081 Ex II 2 G/D	Reinforced plastic housing, rectification diodes and varistor protection are encapsulated, screw termination in terminal box IP66	LCIE 02 ATEX 6023 X
 483371(HZ06)	cable connection		EEx e II T4 CE 0081 Ex II 2 G/D	Metal housing with encapsulated screw terminal coil, internal and external ground screws IP67	LCIE 02 ATEX 6011 X

Notes:

* See page 114 for operating temperature classification codes and maximum allowable surface temperatures.

* IP65 and IP67 according to DIN 40050 and IEC 529 standards. Equivalent to NEMA 4 watertight. See page 122 for statement of Degree of Protection of electrical parts.

3000 SERIES COILS

Coil Code	Type of Termination	Wattage	Description	Coil Code	Type of Termination	Wattage	Description
 M1S1	1/4" Tab	6	Class B Molded	 MC11	1/2" Conduit	6	Class F Integrated NEMA 4X, 18" leads
 M4S1	1/4" Tab	3	Class B Molded	 T1J1	12" leads	6	Class B taped
 M3J5	12" leads	6	Class B Molded	 T3J1	12" leads	3	Class B taped
 M6J5	12" leads	3	Class B Molded				

Notes:

* For all 6 watt coils, actual wattage for 24/60 volt is 7.5.

* Hazardous location coils meet requirements for Class I, Division 1 and 2, Groups A,B,C,D; Class II, Division 1 and 2, Groups E,F,G

* Taped leaded coils contain 24 gauge AWG leads.

* Molded leaded coils contain 22 gauge AWG leads.

* AC coils contain full wave bridge rectifier.

* Molded coils are one piece construction.

Two-Way Valve Contents



Skinner Two-Way Valve Specifications	15-44
Skinner 7000 Series Valves	15-40
General Purpose Valves	15-27
Hot Water and Steam Valves.....	28-32
High Pressure Valves	33-35
Anti-Water Hammer Valves	36-37
Manual Reset Valves.....	38
Remote Pressure Valves.....	39
Skinner 3000 Series Valves	40-41
Skinner B-Series Valves.....	42
Skinner C-Series Valves.....	43
Skinner LB27 Zero Delta P Valves	44

SKINNER 7000

General Purpose Two-Way
Direct Acting Valves

IN THIS SECTION :
7121, 7122, 7123, 7129

SPECIFICATIONS

Mechanical Characteristics

Standard Materials of Construction

- Body—Brass or Stainless Steel (430F)
- Seals—NBR, FKM, PCTFE as listed
- Sleeve Tube—Stainless Steel (303 or 304)
- Plunger—Stainless Steel (430FR)
- Stop—Stainless Steel (430FR)
- Springs—Stainless Steel (18-8)
- Shading Rings—Copper
- Pilot Orifice—Stainless Steel (303)

Compatible Fluids

- Lubricated Air, Non-Lubricated Air, Inert Gases, Water, Hydraulic Fluids, Petroleum Products and additional fluids compatible with materials of construction. Use of non-lubricated gaseous media will substantially limit valve life.

Electrical Characteristics

Voltages

- DC—12, 24
- AC—24/60, 110/50-120/60, 220/50-240/60, (other AC/DC voltages available upon request)

Agency Approvals

- UL and CSA approvals are available on valves with applicable coil/enclosure combinations. For additional information see page 122.

Power Consumption

- 10, 22 watts
- Fluxtron Electronic Coils and Magne latch (refer to page 123 for current draw charts)

Miscellaneous

Maximum Ambient Temperature

- 10 watt AC/DC—150°F
- 22 watt AC/DC—77°F
- Fluxtron/Magne latch—122°F

7121 DIRECT ACTING BRASS VALVES—NORMALLY CLOSED, PCTFE OR FKM SEALS

Pipe Size NPT	Orifice Size (inch)	Cv Factor	Operating Pressure Differential (PSI)				MAX.* Fluid Temp. (F)	Pressure Vessel Number	UL/CSA** Approval	Const. Ref.	
			Min.	Maximum		22 watt					
				10 watt	DC Ratings						
FLG^	1/16	0.11	0	1000	435	165	7121FBF4GF00	GP	1		
	1/8	0.31	0	365	125	165	7121FBF4NF00	GP	1		
1/8	1/16	0.11	0	1000	435	700	7121KBN1GF00	GP	2		
	1/8	0.31	0	365	125	205	7121KBN1NF00	GP	2		
1/4	1/16	0.11	0	1000	435	700	7121KBN2GF00	GP	2		
	1/8	0.31	0	365	125	205	7121KBN2NF00	GP	2		
	1/8	0.31	0	145	125	125	7121KBN2NV00	SS	2		
	5/32	0.52	0	120	60	75	7121KBN2QV00	SS	2		
	13/64	0.76	0	80	30	40	7121KBN2SV00	SS	2		
3/8	1/4	0.83	0	55	20	20	185	7121KBN3UV00	SS	2	
1/2	7/16	2.5	0	17.5	35	5	10	185	7121KBN44V00	SS	3

[^] 2, 3 and 5 station subbases with 1/4" BSP common inlet port and 1/8" BSP outlet port are available for use with D400 and D500 32mm DIN coils only. For details consult factory.

7121 DIRECT ACTING STAINLESS STEEL VALVES—NORMALLY CLOSED, PCTFE OR NBR SEALS

'5' Family valves listed below containing NBR seals are also available with FKM seals.

Pipe Size NPT	Orifice Size (inch)	Cv Factor	Operating Pressure Differential (PSI)				MAX.* Fluid Temp. (F)	Pressure Vessel Number	UL/CSA** Approval	Const. Ref.		
			Min.	Maximum		1000						
				AC Ratings							DC Ratings	
				10 watt	22 watt	10 watt	22 watt					
1/8	3/64	0.06	0	1000		520		1000	165	71215SN1EF00	GP	4
	3/64	0.06	0	450		450			185	71215SN1EN00	SS	4
	1/16	0.1	0	700		350		700	165	71215SN1GF00	GP	4
	1/16	0.1	0	350		350			185	71215SN1GN00	SS	4
	3/32	0.18	0	260	650	130		300	165	71215SN1KF00	GP	4
	3/32	0.18	0	275		275			185	71215SN1KN00	SS	4
	1/8	0.28	0	200	520	100		200	165	71215SN1MF00	GP	4
	1/8	0.28	0	200		150		200	185	71215SN1MN00	SS	4
	5/32	0.4	0	110	150	60		130	185	71215SN1QN00	SS	4
	3/16	0.5	0	80	90	25		70	185	71215SN1SN00	SS	4
1/4	0.75	0	40	70	10		30	185	71215SN1VN00	SS	4	
1/4	3/64	0.06	0	1000		520		1000	165	71215SN2EF00	GP	4
	3/64	0.06	0	450		450			185	71215SN2EN00	SS	4
	1/16	0.1	0	700		350		700	165	71215SN2GF00	GP	4
	1/16	0.1	0	350		350			185	71215SN2GN00	SS	4
	3/32	0.18	0	260	650	130		300	165	71215SN2KF00	GP	4
	3/32	0.18	0	275		275			185	71215SN2KN00	SS	4
	1/8	0.28	0	200	520	100		200	165	71215SN2MF00	GP	4
	1/8	0.28	0	200		150		200	185	71215SN2MN00	SS	4
	5/32	0.4	0	110	150	60		130	185	71215SN2QN00	SS	4
	3/16	0.5	0	80	90	25		70	185	71215SN2SN00	SS	4
3/8	0.75	0	40	70	10		30	185	71215SN2VN00	SS	4	
5/16	1.1	0	20	55	3		10	185	71215SN21N00	SS	5	
3/8	3/8	2	0	6	25			5	185	71215SN33N00	SS	6
	3/8	2	5	11					185	71215SN33NHP***	SS	6

* Maximum fluid temperatures are provided for Class F coils. Valves with FKM seals (letter "V" in 10th position of pressure vessel number) can be used at fluid temperatures up to 240°F on DC and 250°F on AC provided a Class H coil is used.

** UL/CSA Approval Information: SS=Safety Shutoff GP=General Purpose Blank=Not Approved

See page 122 for additional agency approval information.

5-11PSI is the operating pressure range for bubbletight sealing. Valves may leak if the pressure differential falls below 5 PSI. Fluxtron coils not suitable for use with these valves.

DRAWINGS

#4

Port Identification: 2-IN/ 1-OUT

Dimensions: 1.62 DIA, 2.76, 1.95, 2.84, 1.48, 2, 1, .34, .44, .88, .44, .88, 2, 1

Thread: #10-32 NF TH'D x .25 DP - 2 PLC'S

#5

Port Identification: 2-IN/ 1-OUT

Dimensions: 1.62 DIA, 2.76, 1.95, 2.91, 1.88, 2, 1, .38, .61, .88, .44, .44, .88, 2, 1

Thread: #10-32U NF2B TH'D x .25 DP - 2 PLC'S

7000 Series General Purpose Two-Way Direct Acting Valves

#6

Port Identification: 2-IN/ 1-OUT

#1

Port Identification: 1-IN/ 2-OUT

Valve	Dimension			
	H	P	C	L
7121KBN1XXXX	2.63	3.07	1.61	1.57
7121KBN2XXXX	2.63	3.07	1.61	1.57
7121KBN3XXXX	2.57	3.08	1.55	1.97

*"X" denotes multiple digit combinations for brevity.

#2

Port Identification: 1-IN/ 2-OUT

#3

Port Identification: Flow arrow on body indicates flow direction - ports are not marked.

7000 Series General Purpose Two-Way Direct Acting Valves

7122 DIRECT ACTING BRASS VALVES—NORMALLY OPEN, PCTFE SEALS

Pipe Size NPT	Orifice Size (inch)	Cv Factor	Operating Pressure Differential (PSI)				MAX.* Fluid Temp. (F)	Pressure Vessel Number	UL/CSA** Approval	Const. Ref.
			Maximum							
			Min.	AC Ratings		DC Ratings				
10 watt	22 watt	10 watt		22 watt						
1/8	1/16	0.11	0	435		435	165	7122KBN1GF00	GP	96
	3/32	0.21	0	175		175	165	7122KBN1LF00	GP	96
1/4	1/16	0.11	0	435		435	165	7122KBN2GF00	GP	96
	3/32	0.21	0	175		175	165	7122KBN2LF00	GP	96

7122 DIRECT ACTING STAINLESS STEEL VALVES—NORMALLY OPEN, PCTFE SEALS

5' Family valves listed below containing NBR seals are also available with FKM seals.

Pipe Size NPT	Orifice Size (inch)	Cv Factor	Operating Pressure Differential (PSI)				MAX.* Fluid Temp. (F)	Pressure Vessel Number	UL/CSA** Approval	Const. Ref.
			Maximum							
			Min.	AC Ratings		DC Ratings				
10 watt	22 watt	10 watt		22 watt						
1/8"	3/64	0.05	0	750		750	165	71225SN1EF00	GP	99
	1/16	0.11	0	400		400	165	71225SN1GF00	GP	99
	3/32	0.15	0	170		170	165	71225SN1KF00	GP	99
1/4	3/64	0.05	0	750		750	165	71225SN2EF00	GP	99
	1/16	0.11	0	400		400	165	71225SN2GF00	GP	99
	3/32	0.15	0	170		170	165	71225SN2KF00	GP	99

** UL/CSA Approval Information: SS=Safety Shutoff GP=General Purpose Blank=Not Approved See page 122 for additional agency approval information.

DRAWINGS

Technical drawings for valve #99. Front view shows a diameter of 1.62. Side view shows a total length of 2.76 and a mounting bracket length of 1.95. Detail view shows a mounting hole with dimensions .44 and .88. Schematic diagram shows a 2-IN/1-OUT configuration.

#99

Port Identification: 2-IN/ 1-OUT

Technical drawings for valve #96. Front view shows a diameter of 1.62 (41, 1). Side view shows a total length of 2.76 (70, 1) and a mounting bracket length of 1.95 (48, 5). Detail view shows a mounting hole with dimensions .59 (15, 0) and .30 (7, 6). Schematic diagram shows a 1-IN/2-OUT configuration.

#96

Port Identification: 1-IN/ 2-OUT

7000 Series General Purpose Two-Way Direct Acting Valves

7129 DIRECT ACTING STAINLESS STEEL VALVES—NORMALLY OPEN, NBR SEALS

'5' Family valves listed below containing NBR seals are also available with FKM seals.

Pipe Size NPT	Orifice Size (inch)	Cv Factor	Operating Pressure Differential (PSI)				MAX.* Fluid Temp. (F)	Pressure Vessel Number	UL/CSA** Approval	Const. Ref.	
			Min.	Maximum		DC Ratings					
				AC Ratings							
			10 watt	22 watt	10 watt	22 watt					
1/8"	3/64	0.05	0	400		400		185	71295SN1ENJ1	GP	7
	1/16	0.11	0	325		325		185	71295SN1GNJ1	GP	7
	3/32	0.15	0	250		250		185	71295SN1KNJ1	GP	7
1/4"	3/64	0.05	0	400		400		185	71295SN2ENJ1	GP	7
	1/16	0.11	0	325		325		185	71295SN2GNJ1	GP	7
	3/32	0.15	0	250		250		185	71295SN2KNJ1	GP	7

7123 DIRECT ACTING STAINLESS STEEL VALVES—DUAL PURPOSE, NBR SEALS

'5' Family valves listed below containing NBR seals are also available with FKM seals.

Pipe Size NPT	Orifice Size (inch)	Cv Factor	Operating Pressure Differential (PSI)				MAX.* Fluid Temp. (F)	Pressure Vessel Number	UL/CSA** Approval	Const. Ref.	
			Min.	Maximum		DC Ratings					
				AC Ratings							
			10 watt	22 watt	10 watt	22 watt					
1/8	1/32	0.02	0	400		400		185	71235SN1AN00	SS	100
	3/64	0.06	0	180		180		185	71235SN1EN00	SS	100
	1/16	0.1	0	110		110		185	71235SN1GN00	SS	100
	3/32	0.17	0	70		70		185	71235SN1KN00	SS	100
	1/8	0.28	0	45		45		185	71235SN1MN00	SS	100
1/4	1/32	0.02	0	400		400		185	71235SN2AN00	SS	100
	3/64	0.06	0	180		180		185	71235SN2EN00	SS	100
	1/16	0.1	0	110		110		185	71235SN2GN00	SS	100
	3/32	0.17	0	70		70		185	71235SN2KN00	SS	100
	1/8	0.28	0	45		45		185	71235SN2MN00	SS	100

* Maximum fluid temperatures are provided for Class F coils. Valves with FKM seals (letter "V" in 10th position of pressure vessel number) can be used at fluid temperatures up to 240°F on DC and 250°F on AC provided a Class H coil is used.

** UL/CSA Approval Information: SS=Safety Shutoff GP=General Purpose Blank=Not Approved See page 122 for additional agency approval information.

DRAWINGS

#7

Port Identification: 2-IN/ 3-OUT

DRAWINGS

#100

Port Identification: Pressure can be applied to either port.

SKINNER 7000 Series General Purpose Two-Way Direct Lift and Pilot Operated Valves

IN THIS SECTION :
7221, 7222, 7321, 7322, 7423

SPECIFICATIONS

Mechanical Characteristics

Standard Materials of Construction

- Body—Brass or Stainless Steel (316 or 430F)
- Seals—NBR, FKM as listed
- Sleeve Tube—Stainless Steel (303 or 304)
- Plunger—Stainless Steel (430FR)
- Stop—Stainless Steel (430FR)
- Springs—Stainless Steel (18-8)
- Shading Ring—Copper
- Pilot Orifice—Stainless Steel (303)

Compatible Fluids

- Lubricated Air, Non-Lubricated Air, Inert Gases, Water, Hydraulic Fluids, Petroleum Products and additional fluids compatible with materials of construction. Use of non-lubricated gaseous media will substantially limit valve life.

Electrical Characteristics

Voltages

- DC—12, 24
- AC—24/60, 110/50-120/60, 220/50-240/60,(other AC/DC voltages available upon request)

Power Consumption

- 10, 22 watts
- Fluxtron* Electronic Coils and Magnelatch

Agency Approvals

- UL and CSA approvals are available on valves with applicable coil/enclosure combinations. For additional information see page 122.

Miscellaneous

Maximum Ambient Temperature

- 10 watt AC/DC—150°F
- 22 watt AC/DC—77°F
- Fluxtron*/Magnelatch—122°F

*** Fluxtron coils not for use on direct lift valves.**

7221 DIRECT LIFT BRASS VALVES— NORMALLY CLOSED, NBR SEALS

'B' and 'G' Family valves listed below are also available in FKM Seals.

Pipe Size NPT	Orifice Size (inch)	Cv Factor	Operating Pressure Differential (PSI)				MAX.** Fluid Temp. (F)	Pressure Vessel Number	UL/CSA*** Approval	Const. Ref.
			Maximum							
			Min.*	AC Ratings		DC Ratings				
10 watt	22 watt	10 watt		22 watt						
3/8"	5/8	3.0	0	100	40		185	72218BN3TN00	SS	8
	19/32	4.4	0	230	100		185	7221GBN3VN00	SS	9
1/2"	5/8	4.0	0	100	40		185	72218BN4UN00	SS	8
	19/32	4.4	0	230	100		185	7221GBN4VN00	SS	9
3/4"	3/4	5.0	0	100	40		185	72218BN5VN00	SS	8
	19/32	5.5	0	230	100		185	7221GBN51N00	SS	9
1"	19/32	5.5	0	230	100		185	7221GBN61N00	SS	9
	1	11.7	0	230	85		185	7221GBN64N00	SS	9

For Direct Lift Valve With 1" NPT Process Connection Please Go To Page 44.

7221 DIRECT LIFT STAINLESS STEEL VALVES— NORMALLY CLOSED, FKM SEALS

Pipe Size NPT	Orifice Size (inch)	Cv Factor	Operating Pressure Differential (PSI)				MAX.** Fluid Temp. (F)	Pressure Vessel Number	UL/CSA** Approval	Const. Ref.
			Maximum							
			Min.*	AC Ratings		DC Ratings				
10 watt	22 watt	10 watt		22 watt						
3/8"	5/8	3.0	0	100	40		185	72218RN3TV00	SS	8
1/2"	5/8	4.0	0	100	40		185	72218RN4UV00	SS	8
3/4"	3/4	5.0	0	100	40		185	72218RN5VV00	SS	8

* Direct lift valves will open at zero differential pressure, however full flow through the valve will not be safely achieved.

** Maximum fluid temperatures are provided for Class F coils. Valves with FKM seals (letter "V" in 10th position of pressure vessel number) can be used at fluid temperatures up to 240°F on DC and

250°F on AC provided a Class H coil is used.

*** UL/CSA Approval Information: SS= Safety Shutoff GP=General Purpose Blank=Not Approved See page 122 for additional agency approval information.

7000 Series General Purpose Two-Way Direct Lift and Pilot Operated Valves

DRAWINGS

Valve	Dimension			
	H	P	C	L
72218BN3TXXX	3.78	3.23	2.21	2.64
72218BN4UXXX	3.78	3.23	2.21	2.64
72218BN5VXXX	3.99	3.33	2.31	2.72
72218RN3TXXX	3.99	3.33	2.31	2.72
72218RN4UXXX	3.99	3.33	2.31	2.72
72218RN5VXXX	3.99	3.33	2.31	2.72

*X denotes multiple digit combinations for brevity.

#8

Port Identification: P-IN/ --OUT

Valve	Dimension				
	H	P	C	L	W
7221GBN3VXXX	3.66	3.07	2.06	2.95	2.09
7221GBN4VXXX	3.66	3.07	2.06	2.95	2.09
7221GBN51XXX	3.75	3.07	2.06	3.15	2.09
7221GBN61XXX	4.03	3.15	2.12	3.35	2.09
7221GBN64XXX	4.25	3.35	2.34	3.94	2.75

*X denotes multiple digit combinations for brevity.

#9

Port Identification: Flow arrow on body indicates flow direction—ports are not marked.

7222 DIRECT LIFT BRASS VALVES— NORMALLY OPEN, FKM SEALS

Pipe Size NPT	Orifice Size (inch)	Cv Factor	Operating Pressure Differential (PSI)				MAX.** Fluid Temp. (F)	Pressure Vessel Number	UL/CSA*** Approval	Const. Ref.
			Maximum							
			Min.*	AC Ratings		DC Ratings				
	10 watt	22 watt	10 watt	22 watt						
3/8"	5/8	3.0	0	125+		125	185	72228BN3TV00	GP	102
1/2"	5/8	4.0	0	125+		125	185	72228BN4UV00	GP	102
3/4"	3/4	5.0	0	125+		125	185	72228BN5VV00	GP	102

- * Direct lift valves will open at zero differential pressure, however full flow through the valve will not be safely achieved. If full flow is required at zero differential pressure, consult Skinner.
- ** Maximum fluid temperatures are provided for Class F coils. Valves with FKM seals (letter "V" in 10th position of pressure vessel number) can be used at fluid temperatures up to 240°F on DC and 250°F on AC provided a Class H coil is used.
- *** UL/CSA Approval Information: SS=Safety Shutoff GP=General Purpose Blank=Not Approved See page 122 for additional agency approval information.
- + Rating suitable for all 22 watt integrated coils except D300 DIN coil. Consult Skinner Valve for application review.

DRAWINGS

Valve	Dimension			
	H	P	C	L
72228BN3TXXX	4.04	3.49	2.43	2.64
72228BN4UXXX	4.04	3.49	2.43	2.64
72228BN5VXXX	4.24	3.58	2.52	2.72
72228RN3TXXX	4.04	3.49	2.43	2.64
72228RN4UXXX	4.04	3.49	2.43	2.64
72228RN5VXXX	4.24	3.58	2.52	2.72

*X denotes multiple digit combinations for brevity.

#102

Port Identification: P-IN/ --OUT

7222 DIRECT LIFT STAINLESS STEEL VALVES— NORMALLY OPEN, FKM SEALS

Pipe Size NPT	Orifice Size (inch)	Cv Factor	Operating Pressure Differential (PSI)				MAX.** Fluid Temp. (F)	Pressure Vessel Number	UL/CSA*** Approval	Const. Ref.
			Maximum							
			Min.*	AC Ratings		DC Ratings				
	10 watt	22 watt	10 watt	22 watt						
3/8"	5/8	3.0	0	125+		125	185	72228RN3TV00	GP	102
1/2"	5/8	4.0	0	125+		125	185	72228RN4UV00	GP	102
3/4"	3/4	5.0	0	125+		125	185	72228RN5VV00	GP	102

7000 Series General Purpose Two-Way Direct Lift and Pilot Operated Valves

7321 PILOT OPERATED BRASS VALVES—NORMALLY CLOSED, NBR SEALS

'K', '8' and 1/4" '2' Family valves also available with FKM seals

Pipe Size NPT	Orifice Size (inch)	Cv Factor	Operating Pressure Differential (PSI)				MAX.** Fluid Temp. (F)	Pressure Vessel Number	UL/CSA*** Approval	Const. Ref.
			Maximum							
			Min.*	AC Ratings		DC Ratings				
10 watt	22 watt	10 watt		22 watt						
1/4"	1/4	0.76	5	300	300		185	73212BN2MN00	SS	10
	7/16	2.0	3	150	60	150	185	7321KBN2RN00	SS	98
3/8"	1/2	2.4	5	300	300		185	73212BN3SN00	SS	11
	5/8	3.0	5	150	60	150	185	73218BN3TN00	SS	12
	7/16	2.5	3	150	60	150	185	7321KBN3SN00	SS	98
1/2"	1/2	2.8	5	300	300		185	73212BN4TN00	SS	11
	5/8	4.0	5	150	60	150	185	73218BN4UN00	SS	12
	7/16	2.5	3	150	60	150	185	7321KBN4SN00	SS	98
3/4"	3/4	7.3	5	300	300		185	73212BN52N00	SS	13
	3/4	5.0	5	150	60	150	185	73218BN5VN00	SS	12
	25/32	9.6	5	230	60	230	185	7321GBN53N00	SS	14
1"	1	11.0	5	300	300		185	73212BN63N00	SS	13
	1 1/16	13.5	5	125	60	125	185	73218BN64N00	SS	15
	1	12.5	5	230	60	230	185	7321GBN64N00	SS	14
1 1/4"	1 1/8	15.0	5	125	60	125	185	73218BN75N00	SS	15
	1 1/8	19.3	5	230	60	230	185	7321GBN76N00	SS	14
1 1/2"	1 1/4	22.5	5	125	60	125	185	73218BN87N00	SS	16
	1 9/16	29.0	5	230	60	230	185	7321GBN88N00	SS	14
2"	1 9/16	38.6	5	230	60	230	185	7321GBN99N00	SS	14

7321 PILOT OPERATED STAINLESS STEEL VALVES—NORMALLY CLOSED, NBR SEALS

Pipe Size NPT	Orifice Size (inch)	Cv Factor	Operating Pressure Differential (PSI)				MAX.** Fluid Temp. (F)	Pressure Vessel Number	UL/CSA*** Approval	Const. Ref.
			Maximum							
			Min.*	AC Ratings		DC Ratings				
10 watt	22 watt	10 watt		22 watt						
1/4"	1/4	0.76	5	300	300	300	185	73212SN2MN00	SS	17

* Pilot operated valves require the minimum pressure differential specified for proper valve operation.

** Maximum fluid temperatures are provided for Class F coils. Valves with FKM seals (letter "V" in 10th position of pressure vessel number) can be used at fluid temperatures up to 240°F on DC

and 250°F on AC provided a Class H coil is used.

*** UL/CSA Approval Information: SS=Safety Shutoff GP=General Purpose Blank=Not Approved See page 122 for additional agency approval information. 1/4"-2" Family SS valve also available with FKM seals.

DRAWINGS

Valve	Dimension				
	H	P	C	L	R
7321KBN4SXXX	3.56	2.97	1.96	2.17	
7321KBN2RXXX	3.56	2.97	1.96	1.97	
7321KBN3SXXX	3.56	2.97	1.96	1.97	

*X" denotes multiple digit combinations for brevity.
Flow arrow on body indicates flow direction—ports are not marked.

#10-24 UNC TH'D
X .22 DP-2 PLC'S

IN
OUT

#98

Valve	Dimension				
	H	P	C	L	R
73218BN3TXXX	4.38	3.84	2.81	2.64	1.39
73218BN4UXXX	4.38	3.84	2.81	2.64	1.39
73218BN5VXXX	4.59	3.94	2.91	2.72	1.43

*X" denotes multiple digit combinations for brevity.

IN P
R
L
C
P
H
L
R
2.55

IN
OUT

#12

Port Identification: P-IN/ - -OUT

7000 Series General Purpose Two-Way Direct Lift and Pilot Operated Valves

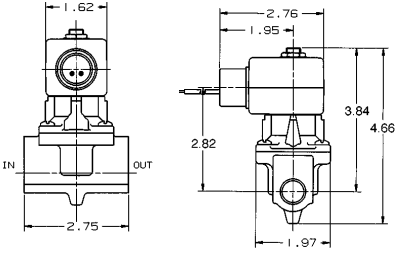
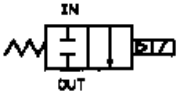
#11

Port Identification: IN-IN/ OUT-OUT

Valve	Dimension		
	H	P	C
73218BN64XXX	5.45	4.59	3.57
73218BN75XXX	5.74	2.97	1.96

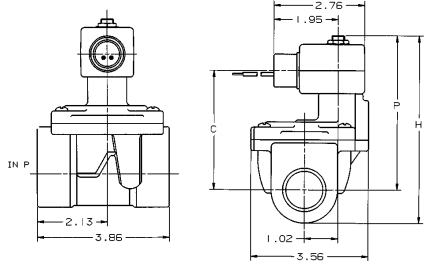
"X" denotes multiple digit combinations for brevity.

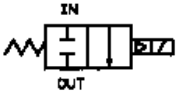

#15

Port Identification: P-IN/ --OUT

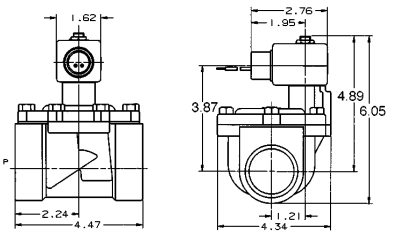
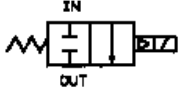
#16

Port Identification: P-IN/ --OUT



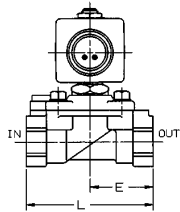

Valve	Dimension			
	H	P	C	L W
7321GBN53XXX	4.75	3.86	2.84	3.94 2.75
7321GBN64XXX	4.75	3.86	2.84	3.94 2.75
7321GBN76XXX	5.41	4.11	3.09	4.33 2.75
7321GBN88XXX	5.66	4.37	3.35	5.51 3.90
7321GBN99XXX	6.25	4.60	3.58	5.91 3.90

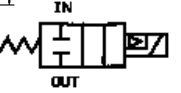
"X" denotes multiple digit combinations for brevity.
Flow arrow on body indicates flow direction—ports are not marked.

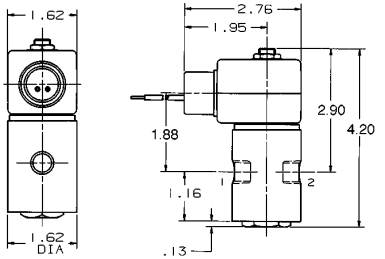
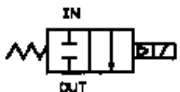

#14

#17

Port Identification: 2-IN/ 1-OUT



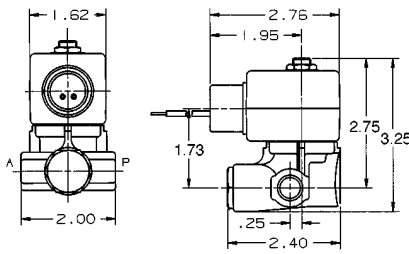
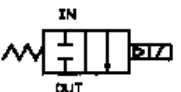

#10

Port Identification: P-IN/ A-OUT

7000 Series General Purpose Two-Way Direct Lift and Pilot Operated Valves

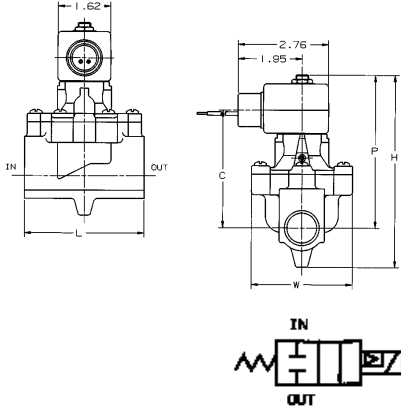
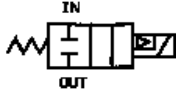
Valve	Dimension					Port Identification	
	H	P	C	L	W	IN	OUT
73212BN52N00	5.81	4.62	3.59	3.62	3.09	IN	OUT
73212BN63N00	6.22	4.89	3.87	4.31	3.45	P	A

#13

7321 PILOT OPERATED BRASS TIMER DRAIN VALVES—NORMALLY CLOSED, FKM SEALS

Pipe Size NPT	Orifice Size (inch)	Cv Factor	Operating Pressure Differential (PSI)				MAX. Fluid Temp. (F)	Pressure Vessel Number	UL/CSA** Approval	Const. Ref.
			Min.*	Maximum						
				10 watt	22 watt					
1/4"	7/16	1.75	3	300	45	210	7321KBY61640	SS	18	
3/8"	7/16	2.5	3	300	45	210	7321KBY63200	SS	18	
1/2"	7/16	2.7	3	300	45	210	7321KBY6320A	SS	18	

* Pilot operated valves require the minimum pressure differential specified for proper valve operation.
 ** UL/CSA Approval Information: SS=Safety Shutoff GP=General Purpose Blank=Not Approved

See page 122 for additional agency approval information.
 NOTE: See Electrical options section on page 121 for timer available for these valves. These valves are rated for intermittent duty cycle applications only.

DRAWINGS

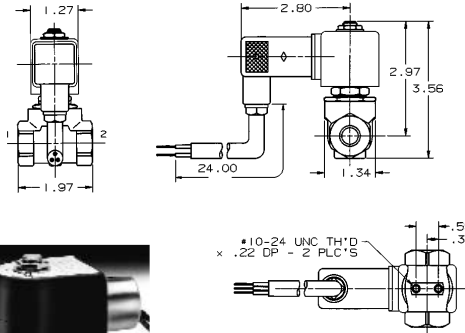
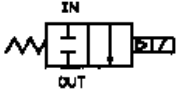
#18

Port Identification: Flow arrow on body indicates flow direction—ports are not marked.

7000 Series General Purpose Two-Way Direct Lift and Pilot Operated Valves

7322 PILOT OPERATED BRASS VALVES— NORMALLY OPEN, NBR SEALS

'8' and 1/4" '2' Family valves listed below are also available in FKM Seals.

Pipe Size NPT	Orifice Size (inch)	Cv Factor	Operating Pressure Differential (PSI)				MAX.** Fluid Temp. (F)	Pressure Vessel Number	UL/CSA*** Approval	Const. Ref.	
			Min.*	Maximum		10 watt					22 watt
				10 watt	22 watt						
1/4"	1/4	0.76	5	200	200	185	73222BN2MN00	GP	104		
3/8"	1/2	2.4	5	200	200	185	73222BN3SN00	GP	105		
	5/8	3.0	5	150	150	185	73228BN3TN00	GP	106		
1/2"	1/2	2.8	5	200	200	185	73222BN4TN00	GP	105		
	5/8	4.0	5	150	150	185	73228BN4UN00	GP	106		
3/4"	3/4	7.3	5	200	200	185	73222BN52N00	GP	107		
	3/4	5.0	5	150	150	185	73228BN5VN00	GP	106		
	25/32	9.6	5	230	230	185	7322GBN53N00	GP	108		
1"	1	11.0	5	200	200	185	73222BN63N00	GP	107		
	1 1/16	13.5	5	125	125	185	73228BN64N00	GP	110		
	1	12.5	5	230	230	185	7322GBN64N00	GP	108		
1 1/4"	1 1/8	15.0	5	125	125	185	73228BN75N00	GP	110		
	1 1/8	19.3	5	230	230	185	7322GBN76N00	GP	108		
1 1/2"	1 1/4	22.5	5	125	125	185	73228BN87N00	GP	111		
	1 9/16	29.0	5	170	170	185	7322GBN88N00	GP	108		
2"	1 9/16	38.6	5	170	170	185	7322GBN99N00	GP	108		

7322 PILOT OPERATED STAINLESS STEEL VALVES— NORMALLY OPEN, NBR SEAL

Pipe Size NPT	Orifice Size (inch)	Cv Factor	Operating Pressure Differential (PSI)				MAX.** Fluid Temp. (F)	Pressure Vessel Number	UL/CSA*** Approval	Const. Ref.	
			Min.*	Maximum		10 watt					22 watt
				10 watt	22 watt						
1/4"	1/4	0.76	5	200	200	185	73222SN2MN00	GP	112		

* Pilot operated valves require the minimum pressure differential specified for proper valve operation.

** Maximum fluid temperatures are provided for Class F coils. Valves with FKM seals (letter "V" in 10th position of pressure vessel number) can be used at fluid temperatures up to 240°F on DC

and 250°F on AC provided a Class H coil is used.

*** UL/CSA Approval Information: SS= Safety Shutoff GP= General Purpose Blank= Not Approved See page 122 for additional agency approval information. 1/4"-2" Family valves listed are also available with FKM seals.

DRAWINGS

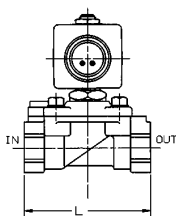

Valve	Dimension				
	H	P	C	L	W
7322GBN53XXX	4.75	3.86	2.84	3.94	2.75
7322GBN64XXX	4.75	3.86	2.84	3.94	2.75
7322GBN76XXX	5.41	4.11	3.09	4.33	2.75
7322GBN88XXX	5.66	4.37	3.35	5.51	3.90
7322GBN99XXX	6.25	4.60	3.58	5.91	3.90

*X denotes multiple digit combinations for brevity.

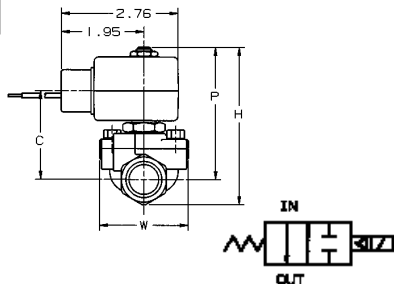

Port Identification: Flow arrow on body indicates flow direction— ports are not marked.



#108

Valve	Dimension				
	H	P	C	L	R
73228BN3TXXX	4.62	4.07	3.01	2.64	1.39
73228BN4UXXX	4.62	4.07	3.01	2.64	1.39
73228BN5VXXX	4.83	4.17	3.11	2.72	1.43

*X denotes multiple digit combinations for brevity.

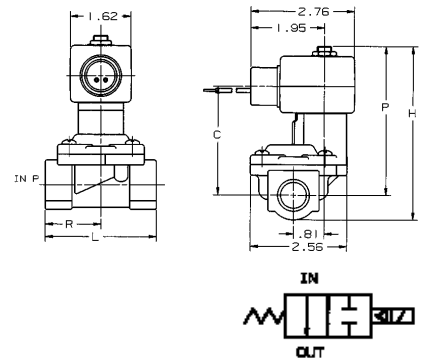

Port Identification: P-IN / - - OUT



#106

7000 Series General Purpose Two-Way Direct Lift and Pilot Operated Valves



Valve	Dimension		
	H	P	C
73228BN64XXX	5.69	4.83	3.77
73228BN75XXX	5.97	4.97	3.91

"X" denotes multiple digit combinations for brevity.

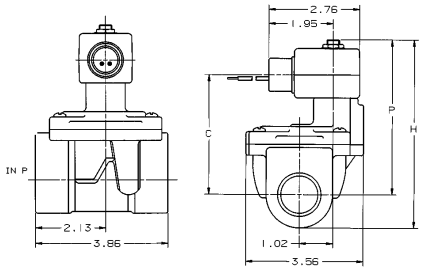
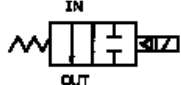
Port Identification: P-IN/ - -OUT

#110

Port Identification: P-IN/ - -OUT

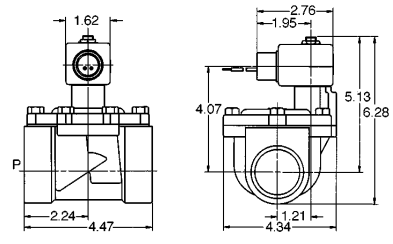
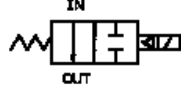
#111

Port Identification: 2-IN/ 1-OUT

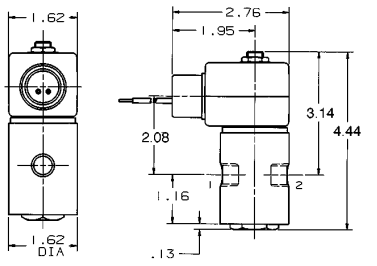
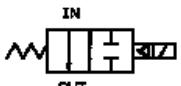
#112

Port Identification: P-IN/ A-OUT

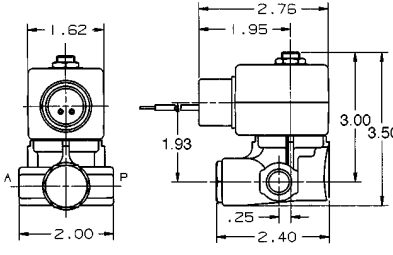
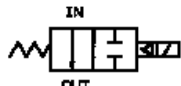
#104

Valve	Dimension						Port Identification	
	H	P	C	L	W	IN	OUT	
73222BN52N00	6.04	4.85	3.79	3.62	3.09	IN	OUT	
73222BN63N00	6.46	5.13	4.07	4.31	3.45	P	A	

Port Identification: P-IN/ - -OUT

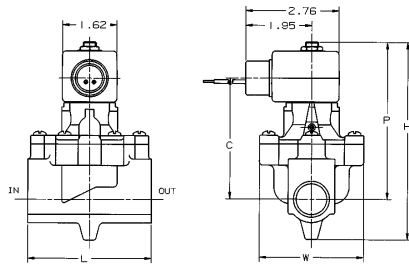
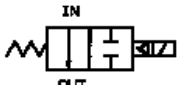
#107

Port Identification: IN-IN/ OUT-OUT

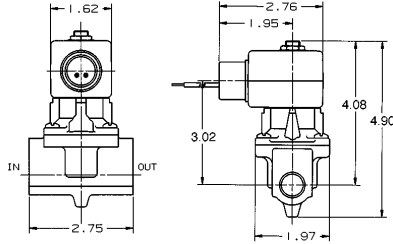
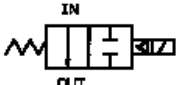
#105

7000 Series General Purpose Two-Way Direct Lift and Pilot Operated Valves

7423 PILOT OPERATED BRASS VALVES— DUAL PURPOSE, NBR SEALS

Pipe Size NPT	Orifice Size (inch)	Cv Factor	Operating Pressure Differential (PSI)				MAX.* Fluid Temp. (F)	Pressure Vessel Number	UL/CSA** Approval	Const. Ref.
			Maximum							
			Min.*	AC Ratings		DC Ratings				
10 watt	22 watt	10 watt		22 watt						
3/8"	1/2	2.4	0	150	150	185	74232BN3SNJ1	GP	19	
1/2"	1/2	2.8	0	150	150	185	74232BN4TNJ1	GP	19	
3/4"	3/4	7.3	0	150	150	185	74232BN52NJ1	GP	20	
1"	1	11.0	0	150	150	185	74232BN63NJ1	GP	20	

* Maximum fluid temperatures are provided for Class F coils. Valves with FKM seals (letter 'V' in 10th position of pressure vessel number) can be used at fluid temperatures up to 240°F on DC and 250°F on AC provided a Class H coil is used.
 Note: External Pilot Pressure valves require a minimum external pilot pressure equal to the main line pressure plus 10 PSI. Maximum external pilot pressure is 145 PSI for vacuum applications, and 160

PSI for pressure applications.
 Pressure ratings may be reduced, however. Consult factory for details.
 ** UL/CSA Approval information: SS= Safety Shutoff GP=General Purpose
 BLANK = Not Approved
 See page 122 for additional agency approval information.

DRAWINGS

#19

IN
OUT

NORMALLY CLOSED

IN
OUT

NORMALLY OPEN

Port Identification: IN-IN/ OUT-OUT
 Note: Valve may be normally closed or normally open, depending on piping of external pilot.

Valve	Dimension						Port Identification	
	H	P	C	L	W	S	IN	OUT
74232BN52NJ1	6.78	5.59	3.59	3.62	3.09	2.28	IN	OUT
74232BN63NJ1	7.19	5.86	3.87	4.31	3.45	2.56	P	A

Valve can be normally closed or normally open, depending on piping of external pilot.

#20

IN
OUT

NORMALLY CLOSED

IN
OUT

NORMALLY OPEN

SKINNER 7000 Series Hot Water and Steam Two-Way, Direct Acting, Direct Lift and Pilot Operated Valves

SPECIFICATIONS

Mechanical Characteristics

Standard Materials of Construction

- Body—Brass or Stainless Steel (316 or 430F)
- Seals—PTFE, EPDM as listed
- Sleeve Tube—Stainless Steel (303 or 304)
- Plunger—Stainless Steel (430FR)
- Piston—Brass
- Piston Seal—PTFE Composite
- Piston Guide—Teflon Composite
- Stop—Stainless Steel (430FR)
- Springs—Stainless Steel (18-8 or 17-7PH)
- Shading Ring—Copper

Compatible Fluids

- Steam to 353°F, Hot Water to 210°F

Electrical Characteristics

Voltagess

- DC—12, 24
- AC—24/60, 110/50-120/60, 220/50-240/60,
(other AC/DC voltages available upon request)

Power Consumption

- 10, 22 watts
- Fluxtron* Electronic Coils and Magnelatch

Agency Approvals

- UL and CSA approvals are available on valves with applicable coil/enclosure combinations. For additional information see page 122.

Miscellaneous

Maximum Ambient Temperature

- 10 watt AC/DC—150°F(-E00 valves), 122°F (-ES0 valves), 77°F(-TS0 valves)
- 22 watt AC/DC—77°F
- Fluxtron*/Magnelatch—122°F

- **Fluxtron coils not suitable for use on direct lift valves. Fluxtron and Magnelatch coils not suitable for use on valves rated for steam service (S0).**

Valves with 'S0' in last two digits of pressure vessel number are rated for steam applications.

DIRECT ACTING BRASS VALVES—NORMALLY CLOSED, EPDM SEALS

Pipe Size NPT	Orifice Size (inch)	Cv Factor	Operating Pressure Differential (PSI)				MAX. Fluid Temp. (F)	Pressure** Vessel Number	UL/CSA*** Approval	Const. Ref.	
			Min.*	Maximum		10 watt					22 watt
				AC Ratings							
1/4	13/64	0.76	0	100	40	100	210	7121KBN2SE00	GP	2	
	13/64	0.76	0	40		40	285	7121KBN2SES0	GP	2	

DIRECT LIFT BRASS VALVES—NORMALLY CLOSED, EPDM SEALS

Pipe Size NPT	Orifice Size (inch)	Cv Factor	Operating Pressure Differential (PSI)				MAX. Fluid Temp. (F)	Pressure** Vessel Number	UL/CSA*** Approval	Const. Ref.	
			Min.*	Maximum		10 watt					22 watt
				AC Ratings							
3/8"	5/8	3.0	0	100		40	210	72218BN3TE00	GP	8	
	5/8	3.0	0	50			297	72218BN3TES0	GP	8	
	19/32	4.4	0	150		100	210	7221GBN3VE00	GP	9	
	19/32	4.4	0	45		45	293	7221GBN3VES0	GP	9	
1/2"	5/8	4.0	0	100		40	210	72218BN4UE00	GP	8	
	5/8	4.0	0	50			297	72218BN4UES0	GP	8	
	19/32	4.4	0	150		100	210	7221GBN4VE00	GP	9	
	19/32	4.4	0	45		45	293	7221GBN4VES0	GP	9	
3/4"	3/4	5.0	0	100		40	210	72218BN5VE00	GP	8	
	3/4	5.0	0	50			297	72218BN5VES0	GP	8	
	19/32	5.5	0	150		100	210	7221GBN51E00	GP	9	
	19/32	5.5	0	45		45	293	7221GBN51ES0	GP	9	
1"	5/8	5.5	0	150		100	210	7221GBN61E00	GP	9	
	5/8	5.5	0	45		45	293	7221GBN61ES0	GP	9	
	1	11.7	0	150		100	210	7221GBN64E00	GP	9	
	1	11.7	0	45		45	293	7221GBN64ES0	GP	9	



7000 Series Hot Water and Steam Two-Way,
Direct Acting, Direct Lift and Pilot Operated Valves

DIRECT LIFT STAINLESS STEEL VALVES– NORMALLY CLOSED, EPDM SEALS

Pipe Size NPT	Orifice Size (inch)	Cv Factor	Operating Pressure Differential (PSI)				MAX. Fluid Temp. (F)	Pressure** Vessel Number	UL/CSA*** Approval	Const. Ref.	
			Min.*	Maximum							
				AC Ratings	DC Ratings						
			10 watt	22 watt	10 watt	22 watt					
3/8"	5/8	3.0	0	100		40	210	72218RN3TE00	GP	8	
	5/8	3.0	0	50			297	72218RN3TES0	GP	8	
1/2"	5/8	4.0	0	100		40	210	72218RN4UE00	GP	8	
	5/8	4.0	0	50			297	72218RN4UES0	GP	8	
3/4"	3/4	5.0	0	100		40	210	72218RN5VE00	GP	8	
	3/4	5.0	0	50			297	72218RN5VES0	GP	8	

DIRECT LIFT BRASS VALVES– NORMALLY OPEN, EPDM SEALS

Pipe Size NPT	Orifice Size (inch)	Cv Factor	Operating Pressure Differential (PSI)				MAX. Fluid Temp. (F)	Pressure** Vessel Number	UL/CSA*** Approval	Const. Ref.	
			Min.*	Maximum							
				AC Ratings	DC Ratings						
			10 watt	22 watt	10 watt	22 watt					
3/8"	5/8	3.0	0		125		210	72228BN3TE00	GP	102	
	5/8	3.0	0	50			297	72228BN3TES0	GP	102	
1/2"	5/8	4.0	0		125		210	72228BN4UE00	GP	102	
	5/8	4.0	0	50			297	72228BN4UES0	GP	102	
3/4"	3/4	5.0	0		125		210	72228BN5VE00	GP	102	
	3/4	5.0	0	50			297	72228BN5VES0	GP	102	

DIRECT LIFT STAINLESS STEEL VALVES– NORMALLY OPEN, EPDM SEALS

Pipe Size NPT	Orifice Size (inch)	Cv Factor	Operating Pressure Differential (PSI)				MAX. Fluid Temp. (F)	Pressure** Vessel Number	UL/CSA*** Approval	Const. Ref.	
			Min.*	Maximum							
				AC Ratings	DC Ratings						
			10 watt	22 watt	10 watt	22 watt					
3/8"	5/8	3.0	0		125		210	72228RN3TE00	GP	102	
	5/8	3.0	0	50			297	72228RN3TES0	GP	102	
1/2"	5/8	4.0	0		125		210	72228RN4UE00	GP	102	
	5/8	4.0	0	50			297	72228RN4UES0	GP	102	
3/4"	3/4	5.0	0		125		210	72228RN5VE00	GP	102	
	3/4	5.0	0	50			297	72228RN5VES0	GP	102	

PILOT OPERATED BRASS VALVES–NORMALLY CLOSED, EPDM OR PTFE SEALS

Pipe Size NPT	Orifice Size (inch)	Cv Factor	Operating Pressure Differential (PSI)				MAX. Fluid Temp. (F)	Pressure** Vessel Number	UL/CSA*** Approval	Const. Ref.	
			Min.*	Maximum							
				AC Ratings	DC Ratings						
			10 watt	22 watt	10 watt	22 watt					
1/4"	7/16	2.0	3	150		60	150	210	7321KBN2RE00	GP	98
	7/16	2.0	3	45			45	293	7321KBN2RES0	GP	98
3/8"	5/8	3.0	5	150		150		210	73218BN3TE00	GP	12
	5/8	3.0	5	50		50		297	73218BN3TES0	GP	12
	5/8	3.0	3	125				353	73218BN3TTS0	GP	21
	7/16	2.5	3	150		60	150	210	7321KBN3SE00	GP	98
	7/16	2.5	3	45			45	293	7321KBN3SES0	GP	98
1/2"	5/8	4.0	5	150		150		210	73218BN4UE00	GP	12
	5/8	4.0	5	50		50		297	73218BN4UES0	GP	12
	5/8	4.0	3	125				353	73218BN4UTS0	GP	21
	7/16	2.5	3	150		60	150	210	7321KBN4SE00	GP	98
	7/16	2.5	3	45			45	293	7321KBN4SES0	GP	98
3/4"	3/4	5.0	5	150		150		210	73218BN5VE00	GP	12
	3/4	5.0	5	50		50		297	73218BN5VES0	GP	12
	5/8	4.5	3	125				353	73218BN5VTS0	GP	21
1"	1 1/16	13.5	5	125		125		210	73218BN64E00	GP	15
	1 1/16	13.5	5	50		50		297	73218BN64ES0	GP	15
	1 1/16	13.5	5	125				353	73218BN64TS0	GP	22
1 1/4"	1 1/8	15.0	5	125		125		210	73218BN75E00	GP	15
	1 1/8	15.0	5	50		50		297	73218BN75ES0	GP	15
	1 1/8	16.0	5	125				353	73218BN75TS0	GP	22
1 1/2"	1 1/4	22.5	5	125		125		210	73218BN87E00	GP	16
	1 1/4	22.5	5	50		50		297	73218BN87ES0	GP	16
	1 1/4	22.5	5	125				353	73218BN87TS0	GP	23

7000 Series Hot Water and Steam Two-Way,
Direct Acting, Direct Lift and Pilot Operated Valves

PILOT OPERATED BRASS VALVES— NORMALLY OPEN, PTFE SEALS

Pipe Size NPT	Orifice Size (inch)	Cv Factor	Operating Pressure Differential (PSI)				MAX. Fluid Temp. (F)	Pressure** Vessel Number	UL/CSA*** Approval	Const. Ref.
			Maximum							
			Min.*	AC Ratings		DC Ratings				
10 watt	22 watt	10 watt		22 watt						
3/8"	5/8	3.0	5	125			73228BN3TTSO	GP	21	
1/2"	5/8	4.0	5	125			73228BN4UTSO	GP	21	
3/4"	3/4	7.5	5	125			73228BN52TTSO	GP	21	
1"	1 1/16	13.5	5	125			73228BN64TTSO	GP	22	
1 1/4"	1 1/8	16.0	5	125			73228BN75TTSO	GP	22	
1 1/2"	1 1/4	22.5	5	125			73228BN87TTSO	GP	23	

* Direct lift valves will open at zero differential pressure, however, full flow through the valve will not be safely achieved. Pilot operated valves require the minimum pressure differential specified for proper valve operation.

** Class H coils are required on steam valves with PTFE seals which are identified by the letters 'TSO'

in the last three digits of the pressure vessel number. Class F coils can be used on all other steam and hot water valves.

***UL/CSA Approval Information: SS=Safety Shutoff GP=General Purpose Blank=Not Approved See page 122 for additional agency information.

DRAWINGS

Valve	Dimension			
	H	P	C	L
73218BN3TTSO	5.12	4.58	3.55	2.65
73218BN4UTSO	5.12	4.58	3.55	2.65
73218BN5VTSO	5.33	4.68	3.65	2.73
73228BN3TTSO	5.36	4.81	3.75	2.65
73228BN4UTSO	5.36	4.81	3.75	2.65
73228BN5VTSO	5.57	4.91	3.85	2.73

#21

NORMALLY CLOSED
NORMALLY OPEN

Port Identification: P-IN/ - - OUT

Valve	Dimension					
	H	P	C	L	W	S
73218BN64TTSO	4.56	3.70	2.38	5.58	3.96	2.94
73218BN75TTSO	4.85	3.85	2.52	5.58	3.96	2.94
73228BN64TTSO	4.56	3.70	2.38	5.82	4.20	3.14
73228BN75TTSO	4.85	3.85	2.52	5.82	4.20	3.14

#22

NORMALLY CLOSED
NORMALLY OPEN

Port Identification: P-IN/ - - OUT

Valve	Dimension			
	H	P	C	L
7121KBN1XXXX	2.63	3.07	1.61	1.57
7121KBN2XXXX	2.63	3.07	1.61	1.57
7121KBN3XXXX	2.57	3.08	1.55	1.97

*X denotes multiple digit combinations for brevity.

#2

Port Identification: 1-IN/ 2-OUT

Valve	Dimension			
	H	P	C	L
72218BN3TXXX	3.78	3.23	2.21	2.64
72218BN4UXXX	3.78	3.23	2.21	2.64
72218BN5VXXX	3.99	3.33	2.31	2.72
72218RN3TXXX	3.99	3.33	2.31	2.72
72218RN4UXXX	3.99	3.33	2.31	2.72
72218RN5VXXX	3.99	3.33	2.31	2.72

*X denotes multiple digit combinations for brevity.

#8

Port Identification: P-IN/ - -OUT

7000 Series Hot Water and Steam Two-Way, Direct Acting, Direct Lift and Pilot Operated Valves

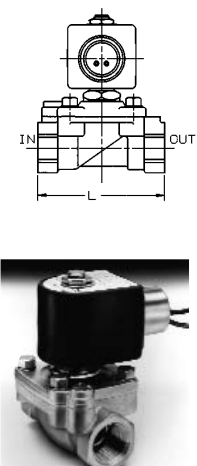

Valve	Dimension				
	H	P	C	L	W
7221GBN3VXXX	3.66	3.07	2.06	2.95	2.09
7221GBN4VXXX	3.66	3.07	2.06	2.95	2.09
7221GBN51XXX	3.75	3.07	2.06	3.15	2.09
7221GBN61XXX	4.03	3.15	2.12	3.35	2.09
7221GBN64XXX	4.25	3.35	2.34	3.94	2.75

*X denotes multiple digit combinations for brevity.

#9

Port Identification: Flow arrow on body indicates flow direction—ports are not marked.

DRAWINGS

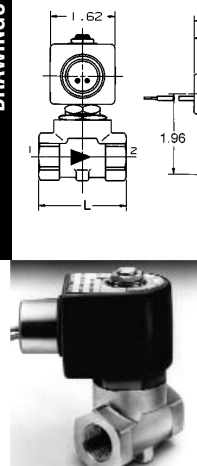

Valve	Dimension			
	H	P	C	L
7321KBN4SXXX	3.56	2.97	1.96	2.17
7321KBN2RXXX	3.56	2.97	1.96	1.97
7321KBN3SXXX	3.56	2.97	1.96	1.97

*X denotes multiple digit combinations for brevity.
Flow arrow on body indicates flow direction—ports are not marked.

*10-24 UNC TH'D
X .22 DP-2 PLC'S

#98

Port Identification: 1-IN/ 2-OUT

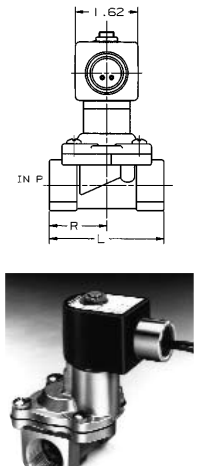

Valve	Dimension				
	H	P	C	L	R
73218BN3TXXX	4.38	3.84	2.81	2.64	1.39
73218BN4UXXX	4.38	3.84	2.81	2.64	1.39
73218BN5VXXX	4.59	3.94	2.91	2.72	1.43

*X denotes multiple digit combinations for brevity.

#12

Port Identification: P-IN/ - -OUT

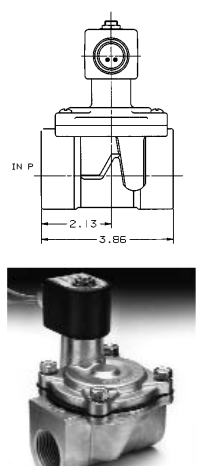

Valve	Dimension		
	H	P	C
73218BN64XXX	5.45	4.59	3.57
73218BN75XXX	5.74	4.73	3.71

*X denotes multiple digit combinations for brevity.

#15

Port Identification: P-IN/ - -OUT



Valve	Dimension		
	B	D	G
73218BN87TSO	6.03	4.08	3.05
73228BN87TSO	6.27	4.32	3.25

#16

Port Identification: P-IN/ - -OUT

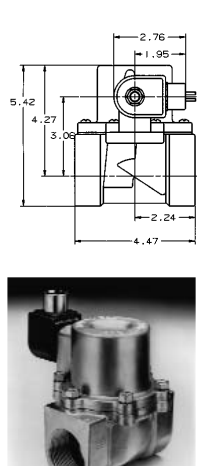

Valve	Dimension		
	B	D	G
73218BN87TSO	6.03	4.08	3.05
73228BN87TSO	6.27	4.32	3.25

#23

Port Identification: P-IN/ - -OUT

NORMALLY CLOSED

NORMALLY OPEN

7000 Series Hot Water and Steam Two-Way,
Direct Acting, Direct Lift and Pilot Operated Valves

DRAWINGS

Valve	Dimension			
	H	P	C	L
72228BN3TXXX	4.04	3.49	2.43	2.64
72228BN4UXXX	4.04	3.49	2.43	2.64
72228BN5VXXX	4.24	3.58	2.52	2.72
72228RN3TXXX	4.04	3.49	2.43	2.64
72228RN4UXXX	4.04	3.49	2.43	2.64
72228RN5VXXX	4.04	3.58	2.52	2.72

*"X" denotes multiple digit combinations for brevity.

Port Identification: P-IN/ - -OUT

#102

Steam Valve Sizing

The following flow charts for saturated steam are based on a valve with a Cv factor = 1. To size valves for steam service ("SO" at end of catalog number), follow these steps:

- 1) Locate the known downstream pressure on the appropriate steam flow chart. From this point draw a horizontal line to intersect the known inlet pressure.
- 2) At this point draw a vertical line down to determine the corresponding steam flow (pounds per hour) for a valve with a Cv = 1.
- 3) Multiply this figure by the Cv factor listed in the catalog for a particular steam valve to determine the actual steam flow through the valve.

For hot water valves refer to page 115, Valve Sizing for Liquid Service.

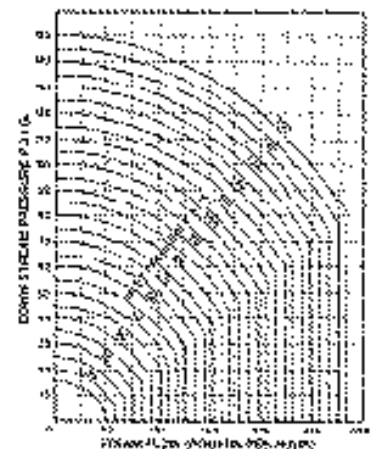
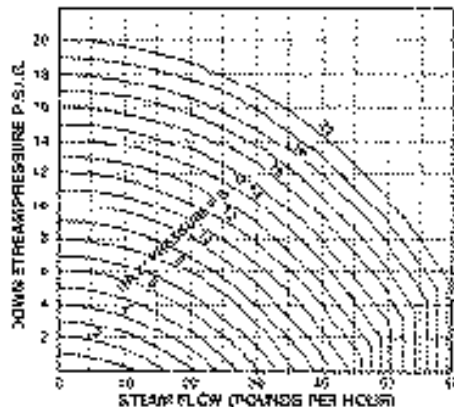

SKINNER 7000 Series High Pressure Two-Way Direct Acting and Pilot Operated Valves

IN THIS SECTION :
7121, 7122, 7321, 7322

SPECIFICATIONS

Mechanical Characteristics

Standard Materials of Construction

- Body—Brass or Stainless Steel (430F)
- Seals—FKM, PCTFE, PTFE, NBR, Nylon, Ruby as listed
- Sleeve Tube—Stainless Steel (303 or 304)
- Pilot Guide—Stainless Steel (303)
- Pilot Orifice—Stainless Steel (303)
- Piston—Stainless Steel (303)
- Plunger—Stainless Steel (430FR)
- Shading Ring—Copper
- Stop—Stainless Steel (430FR)
- Springs—Stainless Steel (18-8)

Compatible Fluids

- All common media including air, inert gases, hydraulic fluids, petroleum products, freons, water, steam and corrosive media. Use of non-lubricated gaseous media will substantially limit valve life.

Power Consumption

- 10, 22 watts

Agency Approvals

- UL and CSA approvals are available on valves with applicable coil/enclosure combinations. For additional information see page 122.

Electrical Characteristics

Voltages

- DC—12, 24
- AC—24/60, 110/50-120/60, 220/50-240/60, (other AC/DC voltages available upon request)

Miscellaneous

Maximum Ambient Temperature

- 10 watt AC/DC—150°F
- 22 watt AC/DC—77°F
- Fluxtron*/Magnetlatch—122°F

DIRECT ACTING BRASS VALVES—NORMALLY CLOSED, PCTFE OR RUBY SEALS

Pipe Size NPT	Orifice Size (inch)	Cv Factor	Operating Pressure Differential (PSI)				MAX.** Fluid Temp. (F)	Pressure Vessel Number	UL/CSA*** Approval	Const. Ref.	
			Min.*	Maximum		DC Ratings					
				AC Ratings	DC Ratings						
			10 watt	22 watt	10 watt	22 watt					
1/8"	1/16	0.11	0	1000		435		165	7121KBN1GF00	GP	97
	3/32	0.24	0	500	725	175	320	210	7121KBN1LR00	GP	97
1/4"	1/16	0.11	0	1000		435		165	7121KBN2GF00	GP	97
	1/16	0.11	0	1100	1450	435	800	210	7121KBN2GR00	GP	97
	5/64	0.17	0	700	1030	260	460	210	7121KBN2JR00	GP	97
	3/32	0.24	0	500	725	175	320	210	7121KBN2LR00	GP	97
	1/8	0.31	0	365	525	125	220	210	7121KBN2NR00	GP	97

DIRECT ACTING STAINLESS STEEL VALVES—NORMALLY CLOSED, PCTFE, NYLON OR PTFE SEALS (Flange Seal-NBR)

Pipe Size NPT	Orifice Size (inch)	Cv Factor	Operating Pressure Differential (PSI)				MAX.** Fluid Temp. (F)	Pressure Vessel Number	UL/CSA*** Approval	Const. Ref.	
			Min.*	Maximum		DC Ratings					
				AC Ratings	DC Ratings						
			10 watt	22 watt	10 watt	22 watt					
1/8"	3/64	0.062	0	1000		520	1000	165	71215SN1EF00	GP	101
	1/16	0.095	0	700		350	700	165	71215SN1GF00	GP	101
	1/32	0.021	0	3000		2500	3000	185	71216SN1BL00	-	101
	3/64	0.037	0	1500		1000	1500	185	71216SN1FU00	GP	101
	1/16	0.070	0	1250		500	1000	185	71216SN1GL00	GP	101
	5/64	0.090	0	500		200	400	185	71216SN1JT00	GP	101
1/4"	3/64	0.062	0	1000		520	1000	165	71215SN2EF00	GP	101
	1/16	0.095	0	700		350	700	165	71215SN2GF00	GP	101
	1/32	0.021	0	3000		2500	3000	185	71216SN2BL00	-	101
	3/64	0.037	0	1500		1000	1500	185	71216SN2FU00	GP	101
	1/16	0.070	0	1250		500	1000	185	71216SN2GL00	GP	101
	5/64	0.090	0	500		200	400	185	71216SN2JT00	GP	101

DIRECT ACTING BRASS VALVES—NORMALLY OPEN, PCTFE OR RUBY SEALS

Pipe Size NPT	Orifice Size (inch)	Cv Factor	Operating Pressure Differential (PSI)				MAX.** Fluid Temp. (F)	Pressure Vessel Number	UL/CSA*** Approval	Const. Ref.	
			Min.*	Maximum		DC Ratings					
				AC Ratings	DC Ratings						
			10 watt	22 watt	10 watt	22 watt					
1/8"	1/16	0.11	0	435		435		165	7122KBN1GF00	GP	97
1/4"	1/16	0.11	0	435		435		165	7122KBN2GF00	GP	97

7000 Series High Pressure Two-Way
Direct Acting and Pilot Operated Valves

DIRECT ACTING STAINLESS STEEL VALVES—NORMALLY OPEN, PCTFE SEALS

Pipe Size NPT	Orifice Size (inch)	Cv Factor	Operating Pressure Differential (PSI)				MAX.** Fluid Temp. (F)	Pressure Vessel Number	UL/CSA*** Approval	Const. Ref.
			Maximum							
			Min.*	AC Ratings		DC Ratings				
10 watt	22 watt	10 watt		22 watt						
1/8"	3/64	0.054	0	750		750		71225SN1EF00	GP	101
	1/16	0.11	0	400		400				
1/4"	3/64	0.054	0	750		750		71225SN2EF00	GP	101
	1/16	0.11	0	400		400				

PILOT OPERATED BRASS VALVES—NORMALLY CLOSED, NBR, PTFE SEALS

'H' Family valves listed are also available in FKM. 'H' Family valves contain ruby plunger seal.

Pipe Size NPT	Orifice Size (inch)	Cv Factor	Operating Pressure Differential (PSI)				MAX.** Fluid Temp. (F)	Pressure Vessel Number	UL/CSA*** Approval	Const. Ref.
			Maximum							
			Min.*	AC Ratings		DC Ratings				
10 watt	22 watt	10 watt		22 watt						
1/4"	1/4	0.76	5	1500		800		73216BN2MT00	GP	10
	5/16	2.5	5	600		435				
3/8"	7/16	3.5	5	600		435		7321HBN3TN00	GP	24
1/2"	9/16	4.1	5	600		435		7321HBN4UN00	GP	24

PILOT OPERATED STAINLESS STEEL VALVES—NORMALLY CLOSED, PTFE SEALS

Pipe Size NPT	Orifice Size (inch)	Cv Factor	Operating Pressure Differential (PSI)				MAX.** Fluid Temp. (F)	Pressure Vessel Number	UL/CSA*** Approval	Const. Ref.
			Maximum							
			Min.*	AC Ratings		DC Ratings				
10 watt	22 watt	10 watt		22 watt						
1/4"	1/4	0.76	5	1500		800		73216SN2MT00	GP	17

PILOT OPERATED BRASS VALVES—NORMALLY OPEN, NBR SEALS

Valves are also available in FKM. 'H' Family valves contain Ruby plunger seals.

Pipe Size NPT	Orifice Size (inch)	Cv Factor	Operating Pressure Differential (PSI)				MAX.** Fluid Temp. (F)	Pressure Vessel Number	UL/CSA*** Approval	Const. Ref.
			Maximum							
			Min.*	AC Ratings		DC Ratings				
10 watt	22 watt	10 watt		22 watt						
1/4"	5/16	2.5	5	600		600		7322HBN2SV00	GP	24
3/8"	7/16	3.5	5	600		600		7322HBN3TN00	GP	24
1/2"	9/16	4.1	5	600		600		7322HBN4UN00	GP	24

* Pilot operated valves require the minimum pressure differential specified for proper valve operation.
 ** Maximum fluid temperatures are provided for Class F coils. Valves with FKM seals (letter 'V' in 10th position of pressure vessel number) can be used at fluid temperatures up to 250°F on DC and 250°F on AC provided a Class H coil is used. Pressure ratings may be reduced, however. Consult factory for details.

***UL/CSA Approval information: SS = Safety Shutoff GP = General Purpose Blank = Not Approved
 See page 122 for additional agency approval information.
 ^ Rating suitable for all 22 watt integrated coils except DIN 300 coil. Consult Fluid Control Division for application review.
 See page 120 for additional seal material combinations.

DRAWINGS

Valve	Dimension H	Dimension C
71215SN1XXXX	2.84	1.48
71215SN2XXXX	2.84	1.48
71216SN1XXXX	2.84	1.48
71216SN2XXXX	2.84	1.48
71225SN1XXXX	3.08	1.68
71225SN2XXXX	3.08	1.68

X* denotes multiple digit combinations for brevity.

#101
Port Identification: 1-OUT/ 2-IN

#97
Port Identification: 1-IN/ 2-OUT

7000 Series High Pressure Two-Way
Direct Acting and Pilot Operated Valves

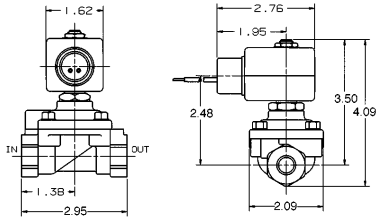
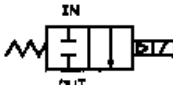
NORMALLY CLOSED

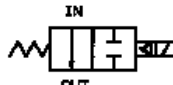

NORMALLY OPEN

Port Identification: Flow arrow on body indicates flow direction—ports are not marked.

#24

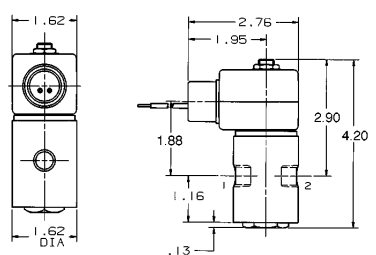
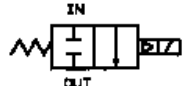
Port Identification: 2-IN/ 1-OUT

#17

Port Identification: P-IN/ A-OUT

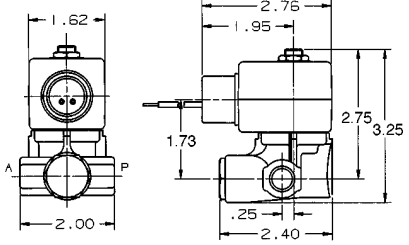
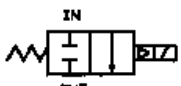
#10

SKINNER 7000 Series Anti-Water Hammer Two-Way Direct Lift and Pilot Operated Valves

SPECIFICATIONS

Mechanical Characteristics

Standard Materials of Construction

- Body—Brass
- Seals—NBR
- Sleeve Tube—Stainless Steel (303 or 304)
- Plunger—Stainless Steel (430FR)
- Shading Ring—Copper
- Stop—Stainless Steel (430FR)
- Springs—Stainless Steel (18-8)
- Pilot Orifice—Stainless Steel (303)

Compatible Fluids

- Water up to 185°F

Electrical Characteristics

Voltagess

- DC—12, 24
- AC—24/60, 110/50-120/60, 220/50-240/60, (other AC/DC voltages available upon request)

Power Consumption

- 10, 22 watts

Agency Approvals

- UL and CSA approvals are available on valves with applicable coil/enclosure combinations. For additional information see page 122.

Miscellaneous

Maximum Ambient Temperature

- 10 watt AC/DC—150°F
- 22 watt AC/DC—77°F
- Fluxtron*/Magnetlatch—122°F
- Fluxtron coils not suitable for use on direct lift valves.

DIRECT LIFT BRASS VALVES—NORMALLY CLOSED, NBR SEALS

Pipe Size NPT	Orifice Size (inch)	Cv Factor	Operating Pressure Differential (PSI)				MAX. Fluid Temp. (F)	Pressure Vessel Number	UL/CSA*** Approval	Const. Ref.	
			Min.*	Maximum		10 watt					22 watt
				AC Ratings	DC Ratings						
3/4"	19/32	5.5	0	230		100	7221GBN51NC0	SS	103		
1"	19/32	5.5	0	230		100	7221GBN61NC0	SS	103		
	1	11.7	0	230		85	7221GBN64NC0	SS	103		

PILOT OPERATED BRASS VALVES—NORMALLY CLOSED, NBR SEALS

Pipe Size NPT	Orifice Size (inch)	Cv Factor	Operating Pressure Differential (PSI)				MAX. Fluid Temp. (F)	Pressure Vessel Number	UL/CSA*** Approval	Const. Ref.	
			Min.*	Maximum		10 watt					22 watt
				AC Ratings	DC Ratings						
3/8"	7/16	2.5	3	150	60	150	7321KBN3SNW0	SS	98		
1/2"	7/16	2.5	3	150	60	150	7321KBN4SNW0	SS	98		
3/4"	3/4	9.6	5	230		230	7321GBN53NMC	GP	109		
1"	1	12.5	5	230		230	7321GBN64NMC	GP	109		
1 1/4"	1 1/8	19.3	5	230		230	7321GBN76NMC	GP	109		
1 1/2"	1 9/16	29.0	5	230		200	7321GBN88NMC	GP	109		
2"	1 9/16	38.6	5	230		200	7321GBN99NMC	GP	109		

PILOT OPERATED BRASS VALVES—NORMALLY OPEN, NBR SEALS

Pipe Size NPT	Orifice Size (inch)	Cv Factor	Operating Pressure Differential (PSI)				MAX. Fluid Temp. (F)	Pressure Vessel Number	UL/CSA*** Approval	Const. Ref.	
			Min.*	Maximum		10 watt					22 watt
				AC Ratings	DC Ratings						
3/4"	3/4	9.6	5	230		230	7322GBN53NC0	GP	109		
1"	1	12.5	5	230		230	7322GBN64NC0	GP	109		
1 1/4"	1 1/8	19.3	5	230		230	7322GBN76NC0	GP	109		
1 1/2"	1 9/16	29.0	5	170		170	7322GBN88NC0	GP	109		
2"	1 9/16	38.6	5	170		170	7322GBN99NC0	GP	109		

**NOTE: Mechanical Options indicated in pressure vessel catalog number (eleventh and twelfth digits) are as follows:
CO=four-step adjustable closing, MC>manual override with four-step adjustable closing, WO=non-adjustable control.**

7000 Series Anti-Water Hammer Two-Way Direct Lift and Pilot Operated Valves

Response Time	Valve Type	Opening Time Range (seconds)	Closing Time Range (seconds)
		7221GBN51NCO	0.03
	7221GBN61NCO	0.04-0.05	0.2-1.7
	7221GBN64NCO	0.07-0.17	0.5-4.0
	7321KBN3SNWO	0.015	0.85
	7321KBN4SNWO	0.015	0.85
	7321GBN53NMC	0.25-0.1	0.6-4.5
	7321GBN64NMC	0.25-0.1	0.6-4.5
	7321GBN76NMC	0.5-0.2	0.8-5.8
	7321GBN88NMC	0.4-0.2	1.5-9.0
	7321GBN99NMC	0.45-0.25	1.5-9.5
	7322GBN53NCO	0.25-0.1	0.6-4.5
	7322GBN64NCO	0.25-0.1	0.6-4.5
	7322GBN76NCO	0.5-0.2	0.8-5.8
	7322GBN88NCO	0.4-0.2	1.5-9.0
	7322GBN99NCO	0.45-0.25	1.5-9.5

DRAWINGS

Valve	Dimension				
	H	P	C	L	W
7321GBN53XXX	4.75	3.86	2.84	3.94	2.75
7322GBN53XXX	4.75	3.86	2.84	3.94	2.75
7321GBN64XXX	4.75	3.86	2.84	3.94	2.75
7322GBN64XXX	4.75	3.86	2.84	3.94	2.75
7321GBN76XXX	5.41	4.11	3.09	4.33	2.75
7322GBN76XXX	5.41	4.11	3.09	4.33	2.75
7321GBN88XXX	5.66	4.37	3.35	5.51	3.90
7322GBN88XXX	5.66	4.37	3.35	5.51	3.90
7321GBN99XXX	6.25	4.60	3.58	5.91	3.90
7322GBN99XXX	6.25	4.60	3.58	5.91	3.90

*"X" denotes multiple digit combinations for brevity.

NORMALLY CLOSED

NORMALLY OPEN

Port Identification: Flow arrow on body indicates flow direction—ports are not marked.

#109

DRAWINGS

Valve	Dimension				
	H	P	C	L	W
7221GBN51XXX	3.75	3.07	2.06	3.15	2.09
7221GBN61XXX	4.03	3.15	2.12	3.35	2.09
7221GBN64XXX	4.25	3.35	2.34	3.94	2.75

*"X" denotes multiple digit combinations for brevity.

NORMALLY CLOSED

NORMALLY OPEN

Port Identification: Flow arrow on body indicates flow direction—ports are not marked.

#103

DRAWINGS

Valve	Dimension			
	H	P	L	
7321KBN4SXXX	3.56	2.97	1.96	2.17
7321KBN2RXXX	3.56	2.97	1.96	1.97
7321KBN3SXXX	3.56	2.97	1.96	1.97

*"X" denotes multiple digit combinations for brevity.

NORMALLY CLOSED

Port Identification: Flow arrow on body indicates flow direction—ports are not marked.

#98

* Direct Lift valves will open at zero differential pressure, however, full flow through the valve will not be safely achieved. Pilot operated valves require the minimum pressure differential specified for proper valve operation.

***UL/CSA Approval Information: SS=Safety Shutoff GP=General Purpose Blank=Not Approved See page 122 for additional agency information.

SKINNER 7000 Series Manual Reset Two-Way Direct Acting and Pilot Operated Valves

SPECIFICATIONS

Mechanical Characteristics

Standard Materials of Construction

- Body—Brass or Stainless Steel (430)
- Seals—NBR or FKM seals as listed
- Sleeve Tube—Stainless Steel (303 or 304)
- Plunger—Stainless Steel (430FR)
- Shading Ring—Copper
- Stop—Stainless Steel (430FR)
- Springs—Stainless Steel (18-8)
- Pilot Orifice—Stainless Steel (303)

Compatible Fluids

- Depending on the valve used, most common media including air, inert gases or petroleum products.

Electrical Characteristics

Voltages

- DC—12, 24
- AC—110/50-120/60, 220/50-240/60

Power Consumption

- 10, 22 watts

Agency Approvals

- cUL approval.

Miscellaneous

Maximum Ambient Temperature

- 131°F

DIRECT ACTING STAINLESS STEEL MANUAL RESET VALVES—NORMALLY CLOSED, FKM SEALS*

Pipe Size NPT	Orifice Size (inch)	Cv Factor	Min.*	Operating Pressure Differential (PSI)				MAX. Fluid Temp. (F)	No-Voltage Release Pressure Vessel	Electrically Tripped Pressure Vessel	Const. Ref.
				Maximum							
				AC Ratings		DC Ratings					
10 watt	22 watt	10 watt	22 watt								
1/4"	3/32	0.18	0	150			150	185	70215SN2KVVR	70215SN2KVET	25

* All wetted parts are stainless steel, FKM and plastic.

PILOT OPERATED BRASS MANUAL RESET VALVES—NORMALLY CLOSED, NBR SEALS

Pipe Size NPT	Orifice Size (inch)	Cv Factor	Min.*	Operating Pressure Differential (PSI)				MAX. Fluid Temp. (F)	No-Voltage Release Pressure Vessel	Electrically Tripped Pressure Vessel	Const. Ref.
				Maximum							
				AC Ratings		DC Ratings					
10 watt	22 watt	10 watt	22 watt								
1/2"	5/8	4.0	5	150			150	185	70218BN4UNVR	70218BN4UNET	25
3/4"	3/4	7.3	5	300			300	185	70212BN52NVR	70212BN52NET	25
1"	1 1/16	13.5	5	125			125	185	70218BN64NVR	70218BN64NET	25
1 1/4"	1 1/8	15.0	5	125			125	185	70218BN75NVR	70218BN75NET	25
1 1/2"	1 1/4	22.5	5	125			125	185	70218BN87NVR	70218BN87NET	25

PILOT OPERATED BRASS MANUAL RESET VALVES—NORMALLY OPEN, NBR SEALS

Pipe Size NPT	Orifice Size (inch)	Cv Factor	Min.*	Operating Pressure Differential (PSI)				MAX. Fluid Temp. (F)	No-Voltage Release Pressure Vessel	Electrically Tripped Pressure Vessel	Const. Ref.
				Maximum							
				AC Ratings		DC Ratings					
10 watt	22 watt	10 watt	22 watt								
3/4"	3/4	7.3	5	300			300	185	70222BN52NVR	70222BN52NET	25
1"	1 1/16	13.5	5	125			125	185	70228BN64NVR	70228BN64NET	25
1 1/4"	1 1/8	15.0	5	125			125	185	70228BN75NVR	70228BN75NET	25
1 1/2"	1 1/4	22.5	5	125			125	185	70228BN87NVR	70228BN87NET	25

* Pilot operated valves require the minimum pressure differential specified for proper valve operation.

DRAWINGS

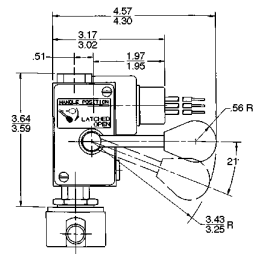

Dimension	No-Voltage Release	Electrically Tripped
A	4.64	4.40
B	4.31	4.07
C	1.79	1.59
D	3.26	3.06



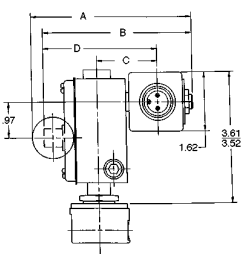

Dimensions apply to Manual Reset feature only.

#25

SKINNER 7000 Series Remote Pressure Operated Two-Way Remote Operated Valves

SPECIFICATIONS

Mechanical Characteristics

Standard Materials of Construction

- Body—Brass
- Seals—NBR
- Springs—Stainless Steel (18-8)
- Pilot Orifice—Stainless Steel (303)

Compatible Fluids

- Lubricated Air, Non-Lubricated Air, Inert Gases, Water, Hydraulic Fluids, Petroleum Products and additional fluids compatible with materials of construction.

Cv Factor

- 2.4 to 11.0

Pipe Sizes

- 3/8" TO 1" NPT

Maximum Operating Pressure Differential

- 190 PSI

REMOTE PRESSURE OPERATED VALVES—DUAL PURPOSE

Pipe Size NPT	Orifice Size (Inch)	Cv Factor	Pressure Vessel Catalog Number	Const. Ref.
3/8"	1/2	2.4	75232BN3SN00	26
1/2"	1/2	2.8	75232BN4TN00	26
3/4"	3/4	7.3	75232BN52N00	26
1"	1	11.0	75232BN63N00	26

TWO-WAY REMOTE OPERATED VALVE PORT CONNECTIONS

Valve Type	Main Line Supply	Remote Control Valve Hookup		Pilot Inlet Port* 1/8" NPT	3-Way Pilot Valve Hookup		
		IN Port	Out Port		Normally Closed Port	Normally Open Port	Common Port
Normally Open	0-190 PSIG	IN	Out	Common Port of 3-Way Pilot Valve	Main Line Pressure + 10 PSI Minimum	Pilot Exhaust	Pilot IN Port (1/8" NPT) of Remote Control Valve
Normally Open	Vacuum	Non-Vacuum Pump	Vacuum Pump		Main Line Pressure + 10 PSI Minimum	Vacuum	
Normally Closed	0-190 PSIG	IN	Out		Pilot Exhaust	Main Line Pressure + 10 PSI Minimum	
Normally Closed	Vacuum	Non-Vacuum Pump	Vacuum Pump		Vacuum	Main Line Pressure + 10 PSI Minimum	

* To assure long, trouble free life, the Pilot IN to main pressure differential should not exceed 200 PSIG.

NOTE: This valve in its normal state, without piloting, is normally open.

DRAWINGS

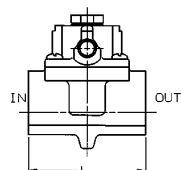

Valve	Dimension					Port Identification	
	H	P	C	L	W	IN	OUT
75232BN3SN00	3.17	2.35	1.51	2.75	1.97	IN	OUT
75232BN4TN00	3.17	2.35	1.51	2.75	1.97	IN	OUT
75232BN52N00	4.31	3.12	2.28	3.62	3.09	IN	OUT
75232BN63N00	4.73	3.40	2.56	4.31	3.45	P	A

Valve can be normally closed or normally open, depending on piping of external pilot.

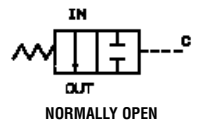
SKINNER 3000 Series Two-Way Direct Acting Valves

SPECIFICATIONS

Mechanical Characteristics

Standard Materials of Construction

- Body—Brass or Stainless Steel (303)
- Seals—NBR, FKM, Ethylene Propylene, CR
- Sleeve Assembly—305 Stainless Steel (tube-flange), 430F Stainless Steel (stop)
- Plunger—430F Stainless Steel
- Manifold Body—Aluminum
- Flux Plate—Plated Steel
- Housing—Plated Steel
- Integrated Coil Encapsulant—Nylon
- Springs—

Compatible Fluids

- Air, inert gas, water, oil

Vacuum

- Up to 5 microns depending on application

Electrical Characteristics

Voltages

- DC 12, 24
- AC—24/50-60, 110/50-120/60, 220/50-240/60

Power Consumption

- 6 watts, 7.5 for 24/60
- 3 watts

Agency Approvals

- UL and CSA component recognition.

Miscellaneous

Maximum Ambient Temperature

- 68°F for continuous duty cycle.

Response Time

- 8 to 16 milliseconds to open or close.

Duty Cycle/Cycle Time

- Continuous duty, 600 cycles per minute.

Weight

- 8 oz.

Mounting

- Two 8-32 tapped holes in bottom of valve body supplied standard. A universal mounting bracket B19-006 is also available. See page 68 for dimensions.

DIRECT ACTING BRASS AND STAINLESS STEEL VALVES—NORMALLY CLOSED

Pipe Size NPT	Body Orifice Size (inch)	Body Cv Factor	Sleeve Orifice Size (inch)	Sleeve Cv Factor	Maximum Operating Pressure Differential (PSI)		Brass Pressure Vessel Catalog Number	Stainless Steel Pressure Vessel Catalog Number
					6 watt	3 watt*		
1/8"	1/32	0.03	-	-	800	775	3121BBN1AN00	3121BSN1AN00
	3/64	0.05	-	-	500	300	3121BBN1EN00	3121BSN1EN00
	1/16	0.09	-	-	300	95	3121BBN1GN00	3121BSN1GN00
	5/64	0.13	-	-	200	65	3121BBN1JN00	3121BSN1JN00
	3/32	0.18	-	-	175	40	3121BBN1LN00	3121BSN1LN00
	1/8	0.24	-	-	100	4	3121BBN1NN00	3121BSN1NN00
	5/32	0.30	-	-	50	-	3121BBN1QN00	3121BSN1QN00

DIRECT ACTING BRASS AND STAINLESS STEEL VALVES—NORMALLY OPEN

Pipe Size NPT	Body Orifice Size (inch)	Body Cv Factor	Sleeve Orifice Size (inch)	Sleeve Cv Factor	Maximum Operating Pressure Differential (PSI)		Brass Pressure Vessel Catalog Number	Stainless Steel Pressure Vessel Catalog Number
					6 watt	3 watt*		
1/8"	-	-	1/32	0.03	300	-	3129BBN1AN00	3129BSN1AN00
	-	-	3/64	0.05	200	-	3129BBN1EN00	3129BSN1EN00
	-	-	1/16	0.09	150	-	3129BBN1GN00	3129BSN1GN00
	-	-	5/64	0.13	80	-	3129BBN1JN00	3129BSN1JN00
	-	-	3/32	0.18	40	-	3129BBN1LN00	3129BSN1LN00

* When ordering a pressure vessel with a 3 watt coil the second digit must be a 9. Example: 3921BBN1AN00 is a 2-way normally closed pressure vessel for use with 3 watt coils.

Performance Ratings Apply to All Voltages, Coil Constructions, Seal and Body Materials.

3000 Series Two-Way Direct Acting Valves

MANIFOLD ASSEMBLED VALVES—NORMALLY CLOSED, COMMON INLET PRESSURE OVER SEAT

Body Orifice Size (inch)	Body Cv Factor	Sleeve Orifice Size (inch)	Sleeve Cv Factor	Maximum Operating Pressure Differential (PSI)		Cavity Manifold Assembly Catalog Number	Screw-In Manifold Assembly** Catalog Number
				6 watt	3 watt*		
3/64	0.05	-	-	500	300	3121BJA7ENC#	3121BSA6EN00
1/16	0.09	-	-	300	95	3121BJA7GNC#	3121BSA6GN00
1/8	0.24	-	-	100	4	-	3121BSA6NN00
5/32	0.30	-	-	50	-	-	3121BSA6QN00

MANIFOLD ASSEMBLED VALVES—NORMALLY OPEN, COMMON INLET PRESSURE OVER SEAT

Body Orifice Size (inch)	Body Cv Factor	Sleeve Orifice Size (inch)	Sleeve Cv Factor	Maximum Operating Pressure Differential (PSI)		Cavity Manifold Assembly Catalog Number	Screw-In Manifold Assembly** Catalog Number
				6 watt	3 watt		
-	-	3/64	0.05	200	-	3129BJA7ENC#	3129BSA6EN00
-	-	1/16	0.09	150	-	3129BJA7GNC#	3129BSA6GN00
-	-	3/32	0.09	40	-	3129BJA7LNC#	3129BSA6LN00

* When ordering a pressure vessel with a 3 watt coil the second digit must be a 9. Example: 3921BSA6EN00 is a 2-way normally closed pressure vessel for use with 3 watt coils. Performance Ratings Apply to All Voltages, Coil Constructions, Seal and Body Materials. Screw-in body available in stainless steel only. Note: Integrated coils not suitable for manifold mounting.

Denotes the number of valves in the manifold, from 2 to 4.
** Screw-in manifolds and valves sold separately. Fitting V1-22-028 available to join manifolds when more than 4 stations required.

Screw-In Manifolds	Common Port	Pressure Direction	Number of Stations		
			2	3	4
2WNC (3121)	Inlet	Over Seat	300-40-015	300-40-016	300-40-017

DRAWINGS

#27

2 way normally closed

Port Identification: 2-IN/ 1-OUT

2 way normally open

Port Identification: 2-IN/ 3*-OUT (*not marked)

#28

SKINNER B-Series General Purpose Two-Way Direct Acting Valves

SPECIFICATIONS

Mechanical Characteristics

Standard Materials of Construction

- Body—Stainless Steel (303)
- Seals—NBR, FKM
- Sleeve—304 Stainless Steel
- Plunger—430F Stainless Steel
- Stop—430 FR Stainless Steel
- Springs—Stainless Steel (18-8)
- Shading Ring—Copper (AC only)
- Orifice 303 Stainless Steel

Compatible Fluids

- Lubricated Air, non-Lubricated Air, Inert Gases, Water, Steam, Hydraulic Fluids, Petroleum Products, Freons, and additional fluids compatible with materials of construction.

Note: Use with Steam and some Petroleum Products normally requires a plunger seal material modification. Consult Fluid Control Division to specify a suitable material.

Minimum Operating Pressure Differential

- 0 PSI

Electrical Characteristics

Voltages

- DC—12, 24
- AC—24/60, 120/60, 240/60

Power Consumption

- 7 watts

Miscellaneous

Vacuum

- Down to 5 microns (0.005 torr, 2x10⁻⁴ in Hg)

Operating Speed

- Up to 800 cycles per minute

Response Time

- AC—Approximately 4-8 milliseconds to open or close.
- DC—Approximately 10-15 milliseconds to open, 6-12 milliseconds to close.

Accessories

- Universal mounting bracket (B19-006)
For Universal mounting Bracket Dimensions see page 68. (3Way section)
- Wrench nut (B99-007)

DIRECT ACTING STAINLESS STEEL VALVES—NORMALLY CLOSED, NBR SEALS

Pipe Size	Orifice Diameter	Cv Factor	Max. Operating Pressure Differential (PSI)		Class A Taped Coil	
			AC	DC	Grommet Enclosure	Const. Ref..
	3/64	0.045	250	250	B2DA1250	113
	1/16	0.065	175	175	B2DA1175	113
	1/8	0.24	50	-	B2DA1052	113
	1/8	0.24	-	25	B2DA1026	113

Ordering B Series Valves:

Example:

- 1) Specify the valve catalog number-B2DA1250
- 2) Specify the required voltage-120V, 60Hz
OR 3. See price book for coil codes

DIRECT ACTING STAINLESS STEEL VALVES—NORMALLY OPEN, FKM SEALS

Pipe Size	Orifice Diameter	Cv Factor	Max. Operating Pressure Differential (PSI)		Class A Taped Coil	
			AC	DC	Grommet Enclosure	Const. Ref.
	3/64	0.054	200	200	B11DK1200	114
	3/32	0.13	40	40	B11DK1040	114

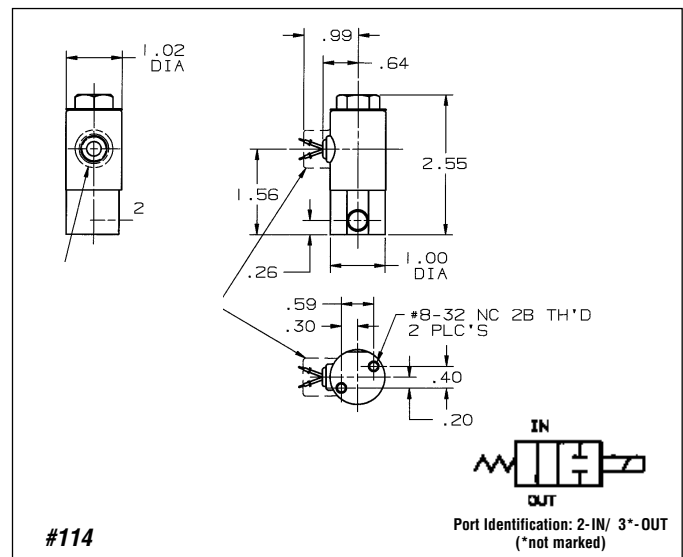
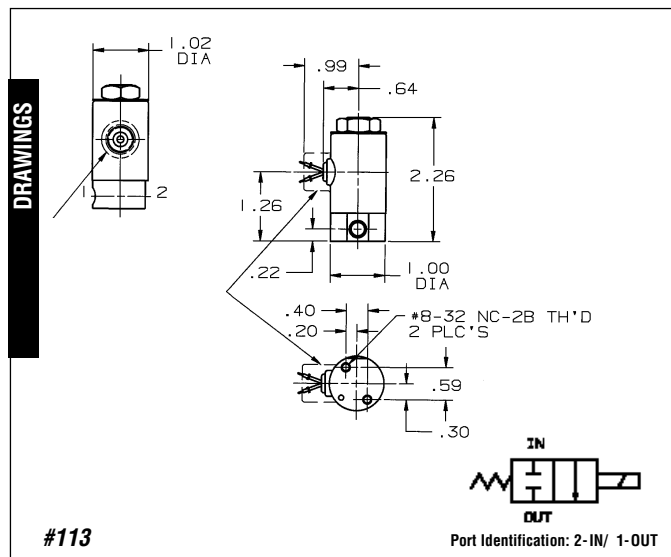

SKINNER C-Series General Purpose Two-Way Direct Acting Valves

SPECIFICATIONS

Mechanical Characteristics

Standard Materials of Construction

- Body—Brass (Stainless Steel available)
- Seals—NBR, EPDM available
- Sleeve—304 Stainless Steel
- Plunger—430FR Stainless Steel
- Stop—430 FR Stainless Steel
- Springs—Stainless Steel (18-8)
- Shading Ring—Copper (AC only)
- Orifice—Brass, Stainless Steel

Compatible Fluids

- Lubricated Air, Non-Lubricated Air, Inert Gases, Water, Steam, Hydraulic Fluids, Petroleum Products, Freons, and additional fluids compatible with materials of construction. Note: Use with Steam may require plunger seal material modification. Consult Fluid Control Division to specify a suitable material.

Minimum Operating Pressure Differential

- 0 PSI

Pipe Sizes

- 1/8" NPT dry seal.

Electrical Characteristics

Voltages

- DC—12, 24, 120
- AC—24/60, 120/60, 240/60 (other voltages available upon request)

Power Consumption

- 8 watts

Agency Approvals

- UL and CSA approvals are generally available on valves with applicable coil/enclosure combinations. For details consult Fluid Control Division.

Miscellaneous

Vacuum

- Down to 5 microns (0.005 torr, 2x10⁻⁴ in Hg)

Operating Speed

- Up to 600 cycles per minute

Response Time

- AC—Approximately 4-8 milliseconds to open or close.
- DC—Approximately 10-15 milliseconds to open, 6-12 milliseconds to close.

Accessories

- Universal mounting bracket (MECHB5)
- Wrench nut

DIRECT ACTING BRASS VALVES—NORMALLY CLOSED, NBR SEALS

NPT Pipe Size	Orifice Diameter	Cv Factor	Max. Operating Pressure Differential (PSI)		Class A Taped Coil Brass Body		Const. Ref.
			AC	DC	Grommet Enclosure	1/2" NPT Conduit	
1/8"	1/16	0.10	275	-	C2DA1277	C2DB1277	31
	1/16	0.10	-	250	C2DA1251	C2DB1251	31
	7/64	0.25	130	-	C2DA1132	C2DB1132	31
	7/64	0.25	-	80	C2DA1081	C2DB1081	31
	1/8	0.31	90	-	C2DA1092	C2DB1092	31
	1/8	0.31	-	50	C2DA1051	C2DB1051	31
	5/32	0.39	60	-	C2DA1062	C2DB1062	31
	5/32	0.39	-	30	C2DA1031	C2DB1031	31

Ordering C Series Valves:

Example:

- 1) Specify the valve catalog number-C2DA1051
 - 2) Specify the required voltage-24 VDC
- OR 3. See price book for coil codes

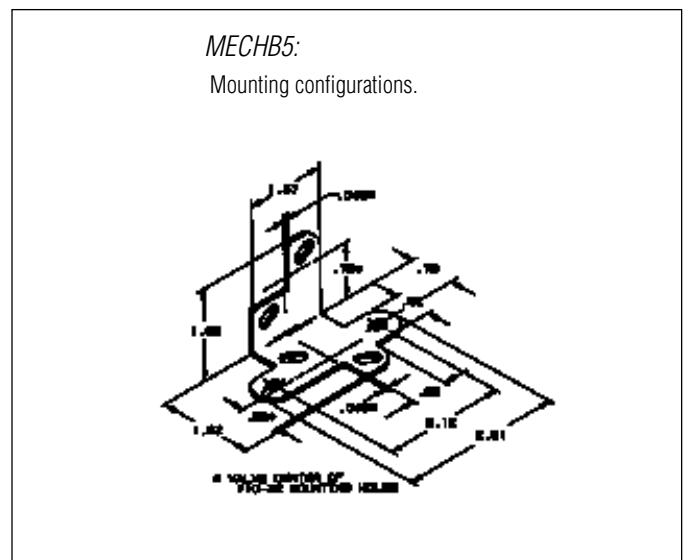
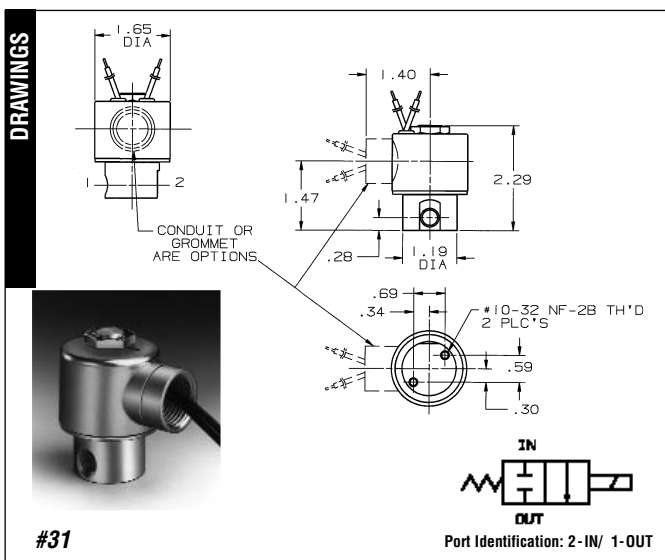

SKINNER LB27 Series Zero Delta P Two-Way Direct Lift Valves

SPECIFICATIONS

Mechanical Characteristics

Standard Materials of Construction

- Body—Brass
- Seals—NBR
- Sleeve—Stainless Steel
- Plunger—Stainless Steel
- Stop—Stainless Steel
- Springs—Stainless Steel
- Shading Ring—Copper

Compatible Fluids

- Lubricated Air, Non-Lubricated Air, Inert Gases, Water, Hydraulic Fluids, Petroleum Products, and additional fluids compatible with materials of construction.

Electrical Characteristics

Voltages

- AC—24/60, 110/50-120/60, 220/50-240/60

Power Consumption

- 20 watts (Normal location)
- 22 watts (Explosion-proof)

Agency Approvals

- Valves are UL listed and CSA certified general purpose for normal location. Explosion-proof valves are UL listed and CSA certified for hazardous locations Class I groups C and D, Class II groups E, F, and G.

Miscellaneous

Maximum Ambient Temperature

- 77°F

Ordering LB27Series Valves:

Example:

- 1) Specify the valve catalog number-XLB27BB8127
- 2) Specify the required voltage-120/60-110/50

BRASS VALVE—NORMALLY CLOSED FOR NORMAL LOCATIONS

Pipe Size NPT	Orifice Size (inch)	Cv Factor	Operating Pressure Differential (PSI)		Max. Fluid Temp. (F)	Catalog Number	Seal Mat'l	Constr. Ref.
			Minimum*	Maximum				
1 1/2"	1 1/4	22.5	0	125	180	LB27BB8127	NBR	33

BRASS VALVE—NORMALLY CLOSED FOR HAZARDOUS LOCATIONS

Pipe Size NPT	Orifice Size (inch)	Cv Factor	Operating Pressure Differential (PSI)		Max. Fluid Temp. (F)	Catalog Number	Seal Mat'l	Constr. Ref.
			Minimum*	Maximum				
1 1/2"	1 1/4	22.5	0	125	180	XLB27BB8127	NBR	34

- * Valves will open at zero differential pressure, however full flow through the valve will not be achieved. If full flow is required at near zero differential, consult factory.
- For Direct Lift valves with other process connection sizes please go to pg 20.

DRAWINGS



#33



#34

Pipe Size	Dimension							
	A	B	C	D	E	F	G	H
1 1/2"	6.55	5.37	4.66	1.70	2.24	2.24	2.15	3.94

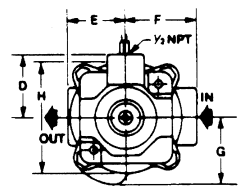
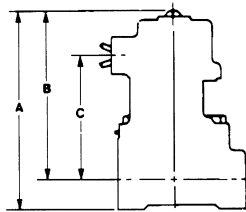
Three-Way Valve Contents

Skinner Three-Way Valve Specifications.....	46-72
Skinner 7000 Series Valves	46-63
General Purpose Valves	46-57
Quick Exhaust Valves	58
High Pressure Valves	59-60
Manual Reset Valves	61-62
Remote Pressure Valves.....	63
Skinner 3000 Series Valves	64-66
Skinner B-Series Valves	67-68
Skinner C-Series Valves	69-70
Skinner A-Series Valves	71-72



SKINNER 7000 Series General Purpose Three-Way Direct Acting Valves

IN THIS SECTION :
7131, 7132, 7133, 7138

SPECIFICATIONS

Mechanical Characteristics

Standard Materials of Construction

- Body—Brass or Stainless Steel (303 or 430F)
- Seals—NBR, FKM, PCTFE as listed
- Sleeve Tube—Stainless Steel (303 or 304)
- Plunger—Stainless Steel (430FR)
- Stop—Stainless Steel (430FR)
- Springs—Stainless Steel (18-8)
- Shading Ring—Copper
- Pilot Orifice—Stainless Steel (303)

Compatible Fluids

- Lubricated Air, Non-Lubricated Air, Inert Gases, Water, Hydraulic Fluids, Petroleum Products and additional fluids compatible with materials of construction. Use of non-lubricated gaseous media will substantially limit valve life.

Electrical Characteristics

Voltages

- DC—12, 24
- AC—24/60, 110/50-120/60, 220/50-240/60, (other AC/DC voltages available upon request)

Agency Approvals

- UL and CSA approvals are available on valves with applicable coil/enclosure combinations. For additional information see page 122.

Miscellaneous

Maximum Ambient Temperature

- 10 watt AC/DC—150°F
- 22 watt AC/DC—77°F
- Fluxtron/Magnelatch—122°F

7131 DIRECT ACTING BRASS VALVES—NORMALLY CLOSED, PCTFE OR FKM SEALS

Pipe Size NPT	Orifice Body NC (inch)	Orifice Body NO (inch)	Orifice Sleeve Size (inch)	Cv Factor NC	Cv Factor NO	Operating Pressure Differential (PSI)				Max.* Fluid Temp. (F)	Pressure Vessel Catalog Number	UL/CSA** Approval	Const. Ref.	
						Min.	Maximum		10 watt					22 watt
							10 watt	22 watt						
FLG^	3/32		3/32	0.24	0.24	0	100		100	185	7131FBF4LV00	GP	36	
1/8"	1/16		1/16	0.11	0.11	0	215		215	185	7131KBN1GV00	GP	37	
	3/32		3/32	0.24	0.24	0	100		100	185	7131KBN1LV00	GP	37	
1/4"	1/32		1/32	0.02	0.02	0	580		580	165	7131KBN2BF00	GP	37	
	1/16		1/16	0.11	0.11	0	215		215	185	7131KBN2GV00	GP	37	
	5/64		3/32	0.17	0.24	0	150		150	185	7131KBN2JV00	GP	37	
	3/32		3/32	0.24	0.24	0	100		100	185	7131KBN2LV00	GP	37	
	5/64	1/8			0.17	0.31	0	150		150	185	7131TBN2JV00	GP	38
	3/32	9/64			0.24	0.38	0	110		110	185	7131TBN2LV00	GP	38
	3/16	1/4			0.49	0.63	0	30		30	185	7131TBN2RV00	GP	38

^ 2, 3 and 5 station subbases with 1/4" BSP common inlet port and 1/8" BSP outlet ports are available for use with D400 and D500 32mm DIN coils only. For details consult factory.

7000 Series General Purpose Three-Way Direct Acting Valves

7131 DIRECT ACTING STAINLESS STEEL VALVES—NORMALLY CLOSED, NBR OR FKM SEALS

'5' Family valves also available with FKM seals.

Pipe Size NPT	Orifice Body NC (inch)	Orifice Body NO (inch)	Orifice Sleeve Size (inch)	Cv Factor NC	Cv Factor NO	Operating Pressure Differential (PSI)				Max.* Fluid Temp. (F)	Pressure Vessel Catalog Number	UL/CSA** Approval	Const. Ref.	
						Min.	Maximum		22 watt					
							10 watt	22 watt						10 watt
1/8"	3/64		1/16	0.062	0.095	0	250		250	185	71315SN1EN00	GP	39	
	3/64		1/16	0.062	0.095	0	250		250	185	71315SN1ENJ1	GP	39	
	1/16		1/16	0.11	0.095	0	200		200	185	71315SN1GN00	GP	39	
	1/16		1/16	0.11	0.095	0	200		200	185	71315SN1GNJ1	GP	39	
	3/32		3/32	0.17	0.17	0	125		125	185	71315SN1KN00	GP	39	
	3/32		3/32	0.17	0.17	0	125		125	185	71315SN1KNJ1	GP	39	
	1/8		3/32	0.23	0.17	0	90		90	185	71315SN1MN00	GP	39	
	1/8		3/32	0.23	0.17	0	90		90	185	71315SN1MNJ1	GP	39	
	3/16		3/32	0.38	0.17	0	25		25	185	71315SN1SN00	GP	39	
	3/16		3/32	0.38	0.17	0	25		25	185	71315SN1SNJ1	GP	39	
	1/4		3/32	0.67	0.17	0	vac		vac	185	71315SN1VNJ1	GP	39	
1/4"	3/64		1/16	0.062	0.095	0	250		250	185	71315SN2EN00	GP	39	
	3/64		1/16	0.062	0.095	0	250		250	185	71315SN2ENJ1	GP	39	
	1/16		1/16	0.11	0.095	0	200		200	185	71315SN2GN00	GP	39	
	1/16		1/16	0.11	0.095	0	200		200	185	71315SN2GNJ1	GP	39	
	3/32		3/32	0.17	0.17	0	125		125	185	71315SN2KN00	GP	39	
	3/32		3/32	0.17	0.17	0	125		125	185	71315SN2KNJ1	GP	39	
	1/8		3/32	0.23	0.17	0	90		90	185	71315SN2MN00	GP	39	
	1/8		3/32	0.23	0.17	0	90		90	185	71315SN2MNJ1	GP	39	
	3/16		3/32	0.38	0.17	0	25		25	185	71315SN2SN00	GP	39	
	3/16		3/32	0.38	0.17	0	25		25	185	71315SN2SNJ1	GP	39	
	1/4		3/32	0.67	0.17	0	vac		vac	185	71315SN2VNJ1	GP	39	
	1/16	1/16			0.095	0.095	0	200		200	185	7131TVN2GV00	GP	40
	5/64	5/64			0.18	0.18	0	150		150	185	7131TVN2JV00	GP	40
	3/32	3/32			0.19	0.19	0	110		110	185	7131TVN2LV00	GP	40
	1/8	1/8			0.32	0.32	0	70		70	185	7131TVN2NV00	GP	40

* Maximum fluid temperatures are provided for Class F coils. Valves with FKM seals (letter 'V' in the 10th position of pressure vessel number) can be used at fluid temperatures up to 240°F on DC and 250°F on AC provided a Class H coil is used.

** UL/CSA Approval Information: GP=General Purpose Blank=Not Approved See page 122 for additional agency approval information.

DRAWINGS

MECHANICAL OPTION "JI" FOR TYPE 71315

MECHANICAL OPTION "MG"

#10-32 NF TH'D
2 X .25 DP
2 PLC'S

Port Identification:
1-Pressure/ 2-Cylinder/ 3-Exhaust

#39

#8-32 UNC TH'D
2 X .18 DP
2 PLC'S

MECHANICAL OPTION "MG"

Port Identification:
1-Pressure/ 2-Cylinder/ 3-Exhaust

#40

Three-Way Solenoid Valves

7000 Series General Purpose Three-Way Direct Acting Valves

#38

Port Identification:
1-Pressure/2-Cylinder/3-Exhaust

#36

Port Identification:
1-Cylinder/2-Pressure/0-Exhaust

#37

Port Identification:
1-Cylinder/2-Pressure/0-Exhaust

Three-Way Solenoid Valves

7000 Series General Purpose Three-Way Direct Acting Valves

7132 DIRECT ACTING BRASS VALVES—NORMALLY OPEN, FKM SEALS

Pipe Size NPT	Orifice Body NC (inch)	Orifice Body NO (inch)	Orifice Sleeve Size (inch)	Cv Factor NC	Cv Factor NO	Operating Pressure Differential (PSI)				Max.* Fluid Temp. (F)	Pressure Vessel Catalog Number	UL/CSA** Approval	Const. Ref.		
						Min.	Maximum		Min.					Maximum	
							AC Ratings							DC Ratings	
1/4"	5/32	1/8		0.31	0.41	0	10 watt	22 watt	150	10 watt	22 watt	185	7132TBN2NV00	GP	118

7139 DIRECT ACTING STAINLESS STEEL VALVES—NORMALLY OPEN, NBR SEALS

'5' family valves also available with FKM seals.

Pipe Size NPT	Orifice Body NC (inch)	Orifice Body NO (inch)	Orifice Sleeve Size (inch)	Cv Factor NC	Cv Factor NO	Operating Pressure Differential (PSI)				Max.* Fluid Temp. (F)	Pressure Vessel Catalog Number	UL/CSA** Approval	Const. Ref.		
						Min.	Maximum		Min.					Maximum	
							AC Ratings							DC Ratings	
1/8"	1/16		3/64	0.10	0.052	0	250		250	185	71395SN1ENJ1	GP	120		
	1/8		1/16	0.28	0.10	0	150		150	185	71395SN1GNJ1	GP	120		
	1/8		3/32	0.28	0.17	0	125		125	185	71395SN1KNJ1	GP	120		
1/4"	1/16		3/64	0.10	0.052	0	250		250	185	71395SN2ENJ1	GP	120		
	1/8		1/16	0.28	0.10	0	150		150	185	71395SN2GNJ1	GP	120		
	1/8		3/32	0.28	0.17	0	125		125	185	71395SN2KNJ1	GP	120		

* Maximum fluid temperatures are provided for Class F coils. Valves with FKM seals (letter 'V' in the 10th position of pressure vessel number) can be used at fluid temperatures up to 250°F on DC and 250°F on AC provided a Class H coil is used. Pressure ratings may be reduced, however. Consult

factory for details.
 ** UL/CSA Approval Information: SS=Safety Shutoff SGP=General Purpose Blank=Not Approved See page 122 for additional agency approval information.

DRAWINGS

Port Identification:
1-Exhaust/ 2-Cylinder/ 3-Pressure

Port Identification:
1-Exhaust/ 2-Cylinder/ 3-Pressure

Three-Way Solenoid Valves

7000 Series General Purpose Three-Way Direct Acting Valves

7133 DIRECT ACTING BRASS VALVES—MULTIPURPOSE, FKM SEALS

Pipe Size NPT	Orifice Body NC (inch)	Orifice Body NO (inch)	Orifice Sleeve Size (inch)	Cv Factor NC	Cv Factor NO	Operating Pressure Differential (PSI)				Max.* Fluid Temp. (F)	Pressure Vessel Catalog Number	UL/CSA** Approval	Const. Ref.
						Maximum							
						AC Ratings		DC Ratings					
Min.	10 watt	22 watt	10 watt	22 watt									
FLG [^]	3/32		3/32	0.24	0.24	0	60		60	185	7133FBF4LVJ1	GP	114
1/8"	1/16		1/16	0.11	0.11	0	150		150	185	7133KBN1GVJ1	GP	116
	5/64		5/64	0.15	0.15	0	100		100	185	7133KBN1JVJ1	GP	116
	3/32		3/32	0.24	0.24	0	60		60	185	7133KBN1LVJ1	GP	116
1/4"	1/32		1/32	0.02	0.02	0	435		435	185	7133KBN2BVJ1	GP	116
	1/16		1/16	0.10	0.10	0	150		150	185	7133KBN2GVJ1	GP	116
	5/64		5/64	0.15	0.15	0	100		100	185	7133KBN2JVJ1	GP	116
	3/32		3/32	0.24	0.24	0	60		60	185	7133KBN2LVJ1	GP	116
	5/64	5/64		0.17	0.17	0	100		100	185	7133TBN2JV00	GP	119
	3/32	3/32		0.19	0.19	0	60		60	185	7133TBN2LV00	GP	119
	1/8	1/8		0.31	0.31	0	30		30	185	7133TBN2NV00	GP	119

* Maximum fluid temperatures are provided for Class F coils. Valves with FKM seals (letter 'V' in the 10th position of pressure vessel number) can be used at fluid temperatures up to 240°F on DC and 250°F on AC provided a Class H coil is used. Pressure ratings may be reduced, however. Consult factory for details.

** UL/CSA Approval Information: SS=Safety Shutoff GP=General Purpose Blank=Not Approved See page 122 for additional agency approval information.

[^] 2, 3 and 5 station subbases with 1/4" BSP outlet ports and 1/8" BSP outlet ports are available for use with D400 and D500 32mm DIN coils only. See page 98

Three-Way Solenoid Valves

#114
Port Identification:
Pressure can be applied at either port.

#116
Port Identification:
Pressure can be applied at either port.

#119
Port Identification:
Pressure can be applied at either port.

DRAWINGS

7000 Series General Purpose Three-Way Direct Acting Valves

7133 DIRECT ACTING STAINLESS STEEL VALVES—MULTIPURPOSE, NBR OR FKM SEALS

'5' family valves also available with FKM seals.

Pipe Size NPT	Orifice Body NC (inch)	Orifice Body NO (inch)	Orifice Sleeve Size (inch)	Cv Factor NC	Cv Factor NO	Operating Pressure Differential (PSI)				Max.* Fluid Temp. (F)	Pressure Vessel Catalog Number	UL/CSA** Approval	Const. Ref.	
						Min.	Maximum		10 watt					22 watt
							10 watt	22 watt						
1/8"	1/32		1/32	0.024	0.024	0	400	400	185	71335SN1ANJ1	GP	121		
	3/64		3/64	0.052	0.052	0	180	180	185	71335SN1ENJ1	GP	121		
	1/16		1/16	0.095	0.095	0	115	115	185	71335SN1GNJ1	GP	121		
	3/32		3/32	0.17	0.17	0	80	80	185	71335SN1KNJ1	GP	121		
1/4"	1/32		1/32	0.024	0.024	0	400	400	185	71335SN2ANJ1	GP	121		
	3/64		3/64	0.052	0.052	0	180	180	185	71335SN2ENJ1	GP	121		
	1/16		1/16	0.095	0.095	0	115	115	185	71335SN2GNJ1	GP	121		
	3/32		3/32	0.17	0.17	0	80	80	185	71335SN2KNJ1	GP	121		
	1/16	1/16		0.095	0.095	0	150	150	185	7133TVN2GV00	GP	123		
	5/64	5/64		0.18	0.18	0	100	100	185	7133TVN2JV00	GP	123		
	3/32	3/32		0.19	0.19	0	60	60	185	7133TVN2LV00	GP	123		
	1/8	1/8		0.32	0.32	0	30	30	185	7133TVN2NV00	GP	123		

DRAWINGS

MECHANICAL OPTION "J1" FOR TYPE 71315

MECHANICAL OPTION "MO"

#10-32 NF TH'D x .25 DP 2 PLC'S

1 3
2

1 = NC, 2 = Common, 3 = NO

#121

#8-32 UNC TH'D x .18 DP 2 PLC'S

MECHANICAL OPTION "MO"

1 3
2

1 = NC, 2 = Common, 3 = NO

#123

Three-Way Solenoid Valves

7000 Series General Purpose Three-Way Direct Acting Valves

7138 DIRECT ACTING STAINLESS STEEL VALVES—DIVERTING, NBR SEALS

'5' family valves also available with FKM seals.

Pipe Size NPT	Orifice Body NC (inch)	Orifice Body NO (inch)	Orifice Sleeve Size (inch)	Cv Factor NC	Cv Factor NO	Operating Pressure Differential (PSI)				Max.* Fluid Temp. (F)	Pressure Vessel Catalog Number	UL/CSA** Approval	Const. Ref.
						Min.	Maximum		22 watt				
							10 watt	22 watt					
1/8"	1/16		1/16	0.095	0.095	0	235		235	185	71385SN1GNJ1	GP	122
	3/32		3/32	0.17	0.17	0	140		140	185	71385SN1KNJ1	GP	122
	1/8		3/32	0.23	0.17	0	125		125	185	71385SN1MNJ1	GP	122
1/4"	1/16		1/16	0.095	0.095	0	235		235	185	71385SN2GNJ1	GP	122
	3/32		3/32	0.17	0.17	0	140		140	185	71385SN2KNJ1	GP	122
	1/8		3/32	0.23	0.17	0	125		125	185	71385SN2MNJ1	GP	122

* Maximum fluid temperatures are provided for Class F coils. Valves with FKM seals (letter 'V' in the 10th position of pressure vessel number) can be used at fluid temperatures up to 240°F on DC and 250°F on AC provided a Class H coil is used.

** UL/CSA Approval Information: GP=General Purpose Blank=Not Approved See page 122 for additional agency approval information.

DRAWINGS

MECHANICAL OPTION "J1" FOR TYPE 71315

1.62

1.62 DIA

.34

2

2.76

1.95

3

3.82 (1/4 NPT)

3.65 (1/8 NPT)

3.12

1.62

2

.44

.88

.44

.88

#10-.32 NF TH'D
x .25 DP
2 PLC'S

1 3

2

Port Identification:
1-NC/ 2-IN/ 3-NO

#122

SKINNER 7000 Series General Purpose Three-Way Pilot Operated Valves

IN THIS SECTION :
7331, 7332, 7338, 7433

SPECIFICATIONS

Mechanical Characteristics

Standard Materials of Construction

- Body—Brass
- Seals—NBR
- Diaphragm Seal—NBR/PTFE
- Sleeve Tube—Stainless Steel (304)
- Plunger—Stainless Steel (430FR)
- Stop—Stainless Steel (430FR)
- Springs—Stainless Steel (18-8)
- Shading Ring—Copper
- Pilot Orifice—Stainless Steel (303)

Compatible Fluids

- Lubricated Air, Non-Lubricated Air, Inert Gases, Water, Hydraulic Fluids, Petroleum Products and additional fluids compatible with materials of construction. Use of non-lubricated gaseous media will substantially limit valve life.

Electrical Characteristics

Voltages

- DC—12, 24
- AC—24/60, 110/50-120/60, 220/50-240/60, (other AC/DC voltages available upon request)

Agency Approvals

- UL and CSA approvals are available on valves with applicable coil/enclosure combinations. For additional information see page 122.

Miscellaneous

Maximum Ambient Temperature

- 10 watt AC/DC—150°F
- 22 watt AC/DC—77°F
- Fluxtron/Magnelatch—122°F

7331 PILOT OPERATED BRASS VALVES—NORMALLY CLOSED, NBR SEALS

Pipe Size NPT	Orifice Body NC (inch)	Orifice Body NO (inch)	Cv Factor NC	Cv Factor NO	Operating Pressure Differential (PSI)				Max. Fluid Temp. (F)	Pressure Vessel Catalog Number	UL/CSA** Approval	Const. Ref.
					Maximum							
					AC Ratings		DC Ratings					
3/8"	3/8	3/8	2.1	2.1	10	180	180		185	73312BN3RNJ0	GP	41
	3/8	3/8	2.1	2.1	10	180	180		185	73312BN3RNJ1	GP	42
1/2"	1/2	1/2	3.6	3.6	10	180	180		185	73312BN4UNJ0	GP	41
	1/2	1/2	3.6	3.6	10	180	180		185	73312BN4UNJ1	GP	42
3/4"	3/4	3/4	7.3	7.3	10	180	180		185	73312BN52NJ0	GP	43
	3/4	3/4	7.3	7.3	10	180	180		185	73312BN52NJ1	GP	44

DRAWINGS

Valve	Dimension									
	H	P	C	L	W	S	T	R	J	K
73312BN3RNJ1	4.89	3.98	1.96	2.97	2.62	0.65	0.59	1.44	1.22	0.91
73312BN4UNJ1	5.10	4.08	2.08	3.38	3.09	0.78	0.69	1.66	1.44	1.06

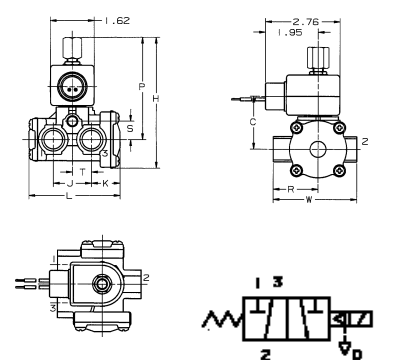
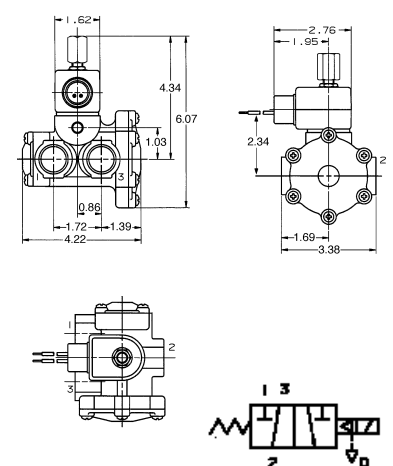
Port Identification:
1-Pressure/ 2-Cylinder/ 3-Exhaust

Port Identification:
1-Pressure/ 2-Cylinder/ 3-Exhaust

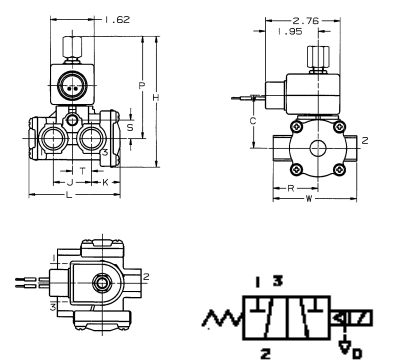
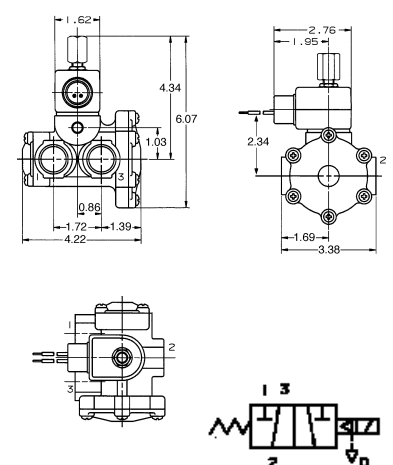
Three-Way Solenoid Valves

7000 Series General Purpose Three-Way Pilot Operated Valves

DRAWINGS

Valve	Dimension									
	H	P	C	L	W	T	R	J	K	
73312BN3RNJO	5.34	4.41	1.96	2.97	2.62	0.59	1.44	1.22	0.91	
73312BN4UNJO	5.62	4.56	2.08	3.38	3.09	0.69	1.66	1.41	1.06	



#41

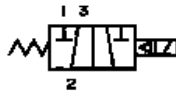
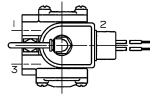
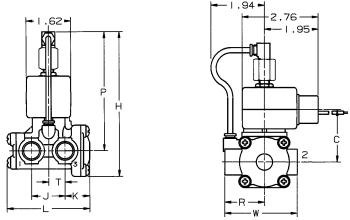

Port Identification:
1-Pressure/ 2-Cylinder/ 3-Exhaust



#43

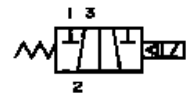
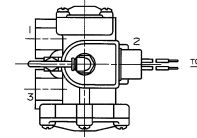
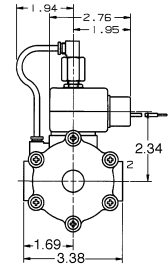
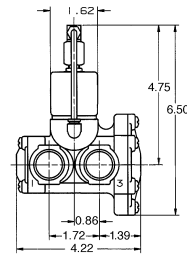

Port Identification:
1-Pressure/ 2-Cylinder/ 3-Exhaust

7000 Series General Purpose Three-Way Pilot Operated Valves

7332 PILOT OPERATED BRASS VALVES—NORMALLY OPEN, NBR SEALS

Pipe Size NPT	Orifice Body NC (inch)	Orifice Body NO (inch)	Cv Factor NC	Cv Factor NO	Operating Pressure Differential (PSI)				Max. Fluid Temp. (F)	Pressure Vessel Catalog Number	UL/CSA** Approval	Const. Ref.
					Maximum							
					AC Ratings		DC Ratings					
Min.*	10 watt	22 watt	10 watt	22 watt								
3/8"	3/8	3/8	2.1	2.1	10	180		180	185	73322BN3RNJ0	GP	124
	3/8	3/8	2.1	2.1	10	180		180	185	73322BN3RNJ1	GP	125
1/2"	1/2	1/2	3.6	3.6	10	180		180	185	73322BN4UNJ0	GP	124
	1/2	1/2	3.6	3.6	10	180		180	185	73322BN4UNJ1	GP	125
3/4"	3/4	3/4	7.3	7.3	10	180		180	185	73322BN52NJ0	GP	128
	3/4	3/4	7.3	7.3	10	180		180	185	73322BN52NJ1	GP	129

DRAWINGS

Valve	Dimension										
	H	P	C	L	W	S	T	R	J	K	
73322BN3RNJ1	4.89	3.98	1.96	2.97	2.62	0.65	0.59	1.44	1.22	0.91	
73322BN4UNJ1	5.10	4.08	2.08	3.38	3.09	0.78	0.69	1.66	1.44	1.06	

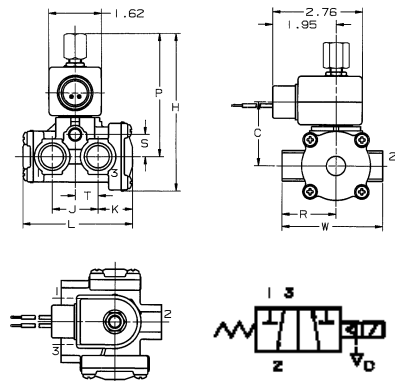

#125

Port Identification:
1-Exhaust/ 2-Cylinder/ 3-Pressure

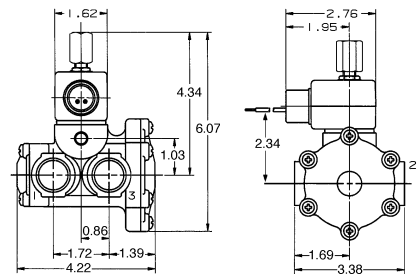

#129

Port Identification:
1-Exhaust/ 2-Cylinder/ 3-Pressure

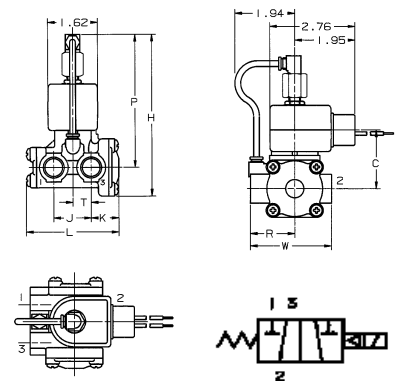

#124

Port Identification:
1-Exhaust/ 2-Cylinder/ 3-Pressure

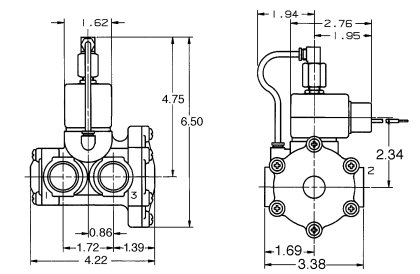

#128

Port Identification:
1-Exhaust/ 2-Cylinder/ 3-Pressure

7000 Series General Purpose Three-Way Pilot Operated Valves

7338 PILOT OPERATED BRASS VALVES—DIVERTING, NBR SEALS

Pipe Size NPT	Orifice Body NC (inch)	Orifice Body NO (inch)	Cv Factor NC	Cv Factor NO	Operating Pressure Differential (PSI)				Max. Fluid Temp. (F)	Pressure Vessel Catalog Number	UL/CSA** Approval	Const. Ref.
					Maximum							
					AC Ratings		DC Ratings					
Min.*	10 watt	22 watt	10 watt	22 watt								
3/8"	3/8	3/8	2.1	2.1	10	180		180	185	73382BN3RNJ1	GP	126
1/2"	1/2	1/2	3.6	3.6	10	180		180	185	73382BN4UNJ1	GP	126
3/4"	3/4	3/4	7.3	7.3	10	180		180	185	73382BN52NJ1	GP	130

* Pilot operated valves require the minimum pressure differential specified for proper valve operation.
 ** UL/CSA Approval Information: GP=General Purpose Blank=Not Approved

See page 122 for additional agency approval information.

DRAWINGS

Valve	Dimension									
	H	P	C	L	W	S	T	R	J	K
73382BN3RNJ1	4.89	3.98	1.96	2.97	2.62	0.65	0.59	1.44	1.22	0.91
73382BN4UNJ1	5.10	4.08	2.08	3.38	3.09	0.78	0.69	1.66	1.44	1.06

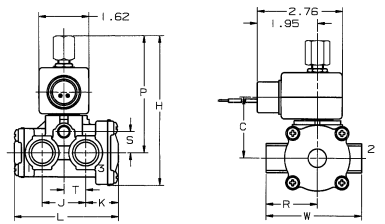
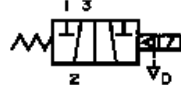
Port Identification:
1-NC/ 2-IN/ 3-NO

Port Identification:
1-NC/ 2-IN/ 3-NO

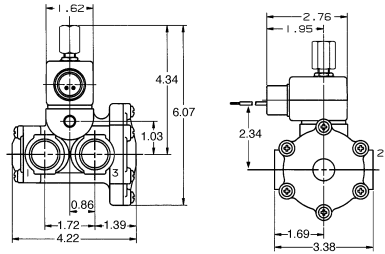
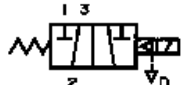
7000 Series General Purpose Three-Way Pilot Operated Valves

External Pilot Pressure Valves

When an application requires the separation of the fluid in the main line from the pilot operator, it is necessary to control the pilot externally. Examples include:

- Controlling contaminated fluids up to 170 PSI.
- Controlling pressures below the minimum

- operating pressure of 10 PSI.
- Operating valves on vacuum.

For such applications, the following 3-way multipurpose valves are provided with connections for external pressure to operate the pilot. The minimum external pilot pressure required is the main line pressure plus 10 PSI. The maximum

external pilot pressure is 180 PSI for pressure applications, and 165 PSI for vacuum applications.

For vacuum service the vacuum line must be connected to the normally open port, and pilot pressure must be connected to the normally closed pilot port.

7433 PILOT OPERATED BRASS VALVES (EXTERNAL PILOT PRESSURE)– MULTIPURPOSE, NBR SEALS

Pipe Size NPT	Orifice Body NC (inch)	Orifice Body NO (inch)	Cv Factor NC	Cv Factor NO	Operating Pressure Differential (PSI)				Max. Fluid Temp. (F)	Pressure Vessel Catalog Number	UL/CSA* Approval	Const. Ref.	
					Maximum								
					AC Ratings		DC Ratings						
					Min.	10 watt	22 watt	10 watt	22 watt				
3/8"	3/8	3/8	2.1	2.1	0	170		170		185	74332BN3RNJ1	GP	127
1/2"	1/2	1/2	3.6	3.6	0	170		170		185	74332BN4UNJ1	GP	127
3/4"	3/4	3/4	7.3	7.3	0	170		170		185	74332BN52NJ1	GP	131

* UL/CSA Approval Information: GP=General Purpose Blank=Not Approved
See page 122 for additional agency approval information.

DRAWINGS

Valve	Dimension										
	H	P	C	L	W	S	T	R	J	K	
74332BN3RNJ1	4.72	3.79	1.96	2.97	2.62	0.65	0.59	1.44	1.22	0.91	
74332BN4UNJ1	4.93	3.91	2.08	3.38	3.09	0.78	0.69	1.66	1.44	1.06	

Port Identification:
Pressure can be applied at either port.

Port Identification:
Pressure can be applied at either port.

SKINNER 7000 Series Quick Exhaust Three-Way Direct Acting Valves

SPECIFICATIONS

Mechanical Characteristics

Standard Materials of Construction

- Body—Stainless Steel (430F), Brass
- Seals—NBR
- Sleeve Tube—Stainless Steel (303 or 304)
- Plunger—Stainless Steel (430FR)
- Stop—Stainless Steel (430FR)
- Springs—Stainless Steel (18-8 or 17-7PH)
- Shading Ring—Copper
- Pilot Orifice—Stainless Steel (303)

Compatible Fluids

- Lubricated Air, Non-Lubricated Air, Inert Gases, Water, Hydraulic Fluids, Petroleum Products and additional fluids compatible with materials of construction. Use of non-lubricated gaseous media will substantially limit valve life.

Electrical Characteristics

Voltages

- DC—12, 24
- AC—24/60, 110/50-120/60, 220/50-240/60,

Agency Approvals

- UL and CSA approvals are available on valves with applicable coil/enclosure combinations. For additional information see page 122.

Miscellaneous

Maximum Ambient Temperature

- 10 watt AC/DC—150°F
- 22 watt AC/DC—77°F
- Fluxtron/Magnelatch—122°F

DIRECT ACTING BRASS VALVES—NORMALLY CLOSED, NBR SEALS

Pipe Size NPT	Orifice Body NC (inch)	Orifice Body NO (inch)	Orifice Sleeve Size (inch)	Cv Factor NC	Cv Factor NO	Operating Pressure Differential (PSI)				Max. Fluid Temp. (F)	Pressure Vessel Catalog Number	UL/CSA** Approval	Const. Ref.	
						Min.*	Maximum		Min.*					Max.
							AC Ratings	DC Ratings						
1/4"	3/32	1/4	3/32	0.2	1.1	0	100	220	100	185	7131EBN2LN00	GP	45	

DIRECT ACTING STAINLESS STEEL VALVES—NORMALLY CLOSED, NBR SEALS

Pipe Size NPT	Orifice Body NC (inch)	Orifice Body NO (inch)	Orifice Sleeve Size (inch)	Cv Factor NC	Cv Factor NO	Operating Pressure Differential (PSI)				Max. Fluid Temp. (F)	Pressure Vessel Catalog Number	UL/CSA** Approval	Const. Ref.	
						Min.*	Maximum		Min.*					Max.
							AC Ratings	DC Ratings						
1/4"	3/64	1/8	3/32	0.052	0.35	0	250	250	250	185	71313SN2EN00	GP	46	
	3/64	1/8	3/32	0.052	0.35	0	250	250	250	185	71313SN2ENJ1	GP	46	
	1/16	1/8	3/32	0.09	0.35	0	200	200	200	185	71313SN2GN00	GP	46	
	1/16	1/8	3/32	0.09	0.35	0	200	200	200	185	71313SN2GNJ1	GP	46	
	3/32	1/8	3/32	0.11	0.35	0	125	125	125	185	71313SN2KN00	GP	46	
	3/32	1/8	3/32	0.11	0.35	0	125	125	125	185	71313SN2KNJ1	GP	46	
	1/8	1/8	3/32	0.13	0.35	0	90	90	90	185	71313SN2MN00	GP	46	
	1/8	1/8	3/32	0.13	0.35	0	90	90	90	185	71313SN2MNJ1	GP	46	

* The valves operate at 0 PSI, however a 2 PSI minimum pressure differential is required to actuate the pressure operated quick exhaust poppet.

** UL/CSA Approval Information: GP=General Purpose Blank=Not Approved See page 122 for additional agency approval information.

DRAWINGS

#46

#45

SKINNER 7000 Series High Pressure Three-Way Direct Acting Valves

SPECIFICATIONS

Mechanical Characteristics

Standard Materials of Construction

- Body—Brass, Stainless Steel (430F)
- Seals FKM, PCTFE, NBR, Ruby as listed
- Sleeve Tube—Stainless Steel (304)
- Plunger—Stainless Steel (430FR)
- Stop—Stainless Steel (430FR)
- Springs—Stainless Steel (18-8)
- Shading Ring—Copper
- Pilot Orifice—Stainless Steel (303)

Compatible Fluids

- All common media including air, inert gases, hydraulic fluids, petroleum products, and water. Use of non-lubricated gaseous media will substantially limit valve life.

Electrical Characteristics

Voltagess

- DC—12, 24
- AC—24/60, 110/50-120/60, 220/50-240/60, (other AC/DC voltages available upon request)

Agency Approvals

- UL and CSA approvals are available on valves with applicable coil/enclosure combinations. For additional information see page 122.

Miscellaneous

Maximum Ambient Temperature

- 10 watt AC/DC—150°F
- 22 watt AC/DC—77°F
- Fluxtron/Magnelatch—122°F

DIRECT ACTING BRASS VALVES—NORMALLY CLOSED, PCTFE OR RUBY SEALS

Pipe Size NPT	Orifice Body NC (inch)	Orifice Body NO (inch)	Cv Factor NC	Cv Factor NO	Operating Pressure Differential (PSI)				Max.* Fluid Temp. (F)	Pressure Vessel Catalog Number	UL/CSA** Approval	Const. Ref.	
					Min.	Maximum		Min.					Max.
						AC Ratings	DC Ratings						
1/4"	1/32	1/32	0.02	0.02	0	580	580	165	7131KBN2BF00	GP	117		
	1/32	1/32	0.02	0.02	0	1100	1100	210	7131KBN2BR00	GP	117		
	3/64	1/16	0.055	0.11	0	435	435	210	7131KBN2ER00	GP	117		

DIRECT ACTING BRASS VALVES—MULTIPURPOSE, FKM SEALS

Pipe Size NPT	Orifice Body NC (inch)	Orifice Body NO (inch)	Cv Factor NC	Cv Factor NO	Operating Pressure Differential (PSI)				Max.* Fluid Temp. (F)	Pressure Vessel Catalog Number	UL/CSA** Approval	Const. Ref.	
					Min.	Maximum		Min.					Max.
						AC Ratings	DC Ratings						
1/4"	1/32	1/32	0.02	0.02	0	435	435	185	7133KBN2BVJ1	GP	117		

DIRECT ACTING STAINLESS STEEL VALVES—MULTIPURPOSE, NBR SEALS

Pipe Size NPT	Orifice Body NC (inch)	Orifice Body NO (inch)	Cv Factor NC	Cv Factor NO	Operating Pressure Differential (PSI)				Max.* Fluid Temp. (F)	Pressure Vessel Catalog Number	UL/CSA** Approval	Const. Ref.	
					Min.	Maximum		Min.					Max.
						AC Ratings	DC Ratings						
1/8"	1/32	1/32	0.024	0.024	0	400	400	185	71335SN1ANJ1	GP	121		
1/4"	1/32	1/32	0.024	0.024	0	400	400	185	71335SN2ANJ1	GP	121		

* Maximum fluid temperatures are provided for Class F coils. Valves with Ruby or FKM seals (letter 'R' or 'V' in 10th position of pressure vessel number) can be used at fluid temperatures up to 240°F on DC and 250°F on AC provided a Class H coil is used.

** UL/CSA Approval Information: GP=General Purpose Blank=Not Approved See page 122 for additional agency approval information.

7000 Series High Pressure Three-Way Direct Acting Valves

DRAWINGS

MECHANICAL OPTION "J1" FOR TYPE 71315

1.62
2
1.62 DIA
.34

2.76
1.95
3
3.62 (1/4 NPT)
3.65 (1/8 NPT)
3.12
1.82
2

*10-32 NF TH'D
.25 DP = 2 PLC'S

.44
.88
.44
.88

1 3
2

Port Identification:
Pressure can be applied at either port.

#121

MECHANICAL OPTION "J1" FOR TYPE 7133KEN

1.62
2
1.57

2.76
1.95
3
2.90
3.34
.77

*10-24 UNC 2A
.22 DP = 2 PLC'S

.59
.30

2 0
1

NORMALLY CLOSED
Port Identification:
1-Cylinder/ 2-Pressure/ 0-Exhaust

2 0
1

MULTIPURPOSE
Port Identification:
Pressure can be applied at either port.

#117

SKINNER 7000 Series Manual Reset Three-Way Direct Acting and Pilot Operated Valves

SPECIFICATIONS

Mechanical Characteristics

Standard Materials of Construction

- Body—Brass or Stainless Steel (430)
- Seals—NBR or FKM seals as listed
- Sleeve Tube—Stainless Steel (303 or 304)
- Plunger—Stainless Steel (430FR)
- Shading Ring—Copper
- Stop—Stainless Steel (430FR)
- Springs—Stainless Steel (18-8)
- Pilot Orifice—Stainless Steel (303)

Compatible Fluids

- Depending on the valve used, most common media including air, inert gases or petroleum products.

Electrical Characteristics

Voltages

- DC—12, 24
- AC—110/50-120/60, 220/50-240/60

Power Consumption

- 10, 22 watts

Agency Approvals

- cUL approval.

Miscellaneous

Maximum Ambient Temperature

- 131°F

DIRECT ACTING STAINLESS STEEL VALVES—NORMALLY CLOSED, NBR OR FKM SEALS

Pipe Size NPT	Orifice Size (inch)	Cv Factor	Operating Pressure Differential (PSI)				No-Voltage Release Pressure Vessel Number	Electrically Tripped Pressure Vessel Number	Const. Ref.	
			Min.*	Maximum		10 watt				22 watt
				AC Ratings	DC Ratings					
			10 watt	22 watt	10 watt	22 watt				
1/4"	3/64 x 3/32	0.062 x 0.17	0	200			200	70315SN2ENVR	70315SN2ENET	25
	1/16 x 3/32	0.11 x 0.17	0	150			150	70315SN2GVVR	70315SN2GVET	25
	3/32 x 3/32	0.17 x 0.17	0	90			90	70315SN2KVVR	70315SN2KVET	25
	1/8 x 3/32	0.23 x 0.17	0	60			60	70315SN2MNVVR	70315SN2MNET	25

PILOT OPERATED BRASS VALVES—NORMALLY CLOSED, NBR SEALS

Pipe Size NPT	Orifice Size (inch)	Cv Factor	Operating Pressure Differential (PSI)				No-Voltage Release Pressure Vessel Number	Electrically Tripped Pressure Vessel Number	Const. Ref.	
			Min.*	Maximum		10 watt				22 watt
				AC Ratings	DC Ratings					
			10 watt	22 watt	10 watt	22 watt				
3/8"	3/8	2.1	10	180			180	70312BN3RNVR	70312BN3RNET	25
1/2"	1/2	3.6	10	180			180	70312BN4UNVR	70312BN4UNET	25
3/4"	3/4	7.3	10	180			180	70312BN52NVR	70312BN52NET	25

DIRECT ACTING STAINLESS STEEL VALVES—NORMALLY OPEN, NBR SEALS

Pipe Size NPT	Orifice Size (inch)	Cv Factor	Operating Pressure Differential (PSI)				No-Voltage Release Pressure Vessel Number	Electrically Tripped Pressure Vessel Number	Const. Ref.	
			Min.*	Maximum		10 watt				22 watt
				AC Ratings	DC Ratings					
			10 watt	22 watt	10 watt	22 watt				
1/4"	1/16 x 3/32	0.095 x 0.17	0	150			150	70325SN2GNVR	70325SN2GNET	25

PILOT OPERATED BRASS VALVES—NORMALLY OPEN, NBR SEALS

Pipe Size NPT	Orifice Size (inch)	Cv Factor	Operating Pressure Differential (PSI)				No-Voltage Release Pressure Vessel Number	Electrically Tripped Pressure Vessel Number	Const. Ref.	
			Min.*	Maximum		10 watt				22 watt
				AC Ratings	DC Ratings					
			10 watt	22 watt	10 watt	22 watt				
3/8"	5/8	2.1	10	180			180	70322BN3RNVR	70322BN3RNET	25
1/2"	1/2	3.6	10	180			180	70322BN4UNVR	70322BN4UNET	25
3/4"	3/4	7.3	10	180			180	70322BN52NVR	70322BN52NET	25

DIRECT ACTING BRASS VALVES—UNIVERSAL ALL-PORTS-IN-BODY, FKM SEALS

Pipe Size NPT	Orifice Size (inch)	Cv Factor	Operating Pressure Differential (PSI)				No-Voltage Release Pressure Vessel Number	Electrically Tripped Pressure Vessel Number	Const. Ref.	
			Min.*	Maximum		10 watt				22 watt
				AC Ratings	DC Ratings					
			10 watt	22 watt	10 watt	22 watt				
1/4"	5/64 x 5/64	0.14 x 0.14	0	100			100	7033TBN2JVVR	7033TBN2JVET	25
1/4"	1/8 x 1/8	0.23 x 0.23	0	50			50	7033TBN2NVVR	7033TBN2NVET	25

* Pilot operated valves require the minimum pressure differential specified for proper valve operation.

7000 Series Manual Reset Three-Way
Direct Acting and Pilot Operated Valves

DIRECT ACTING 303 STAINLESS STEEL VALVES—UNIVERSAL ALL-PORTS-IN-BODY, FKM SEALS**

Pipe Size NPT	Orifice Size (inch)	Cv Factor	Operating Pressure Differential (PSI)				No-Voltage Release Pressure Vessel Number	Electrically Tripped Pressure Vessel Number	Const. Ref.	
			Min.*	Maximum		10 watt				22 watt
				AC Ratings						
1/4"	1/16 x 1/16	0.095 x 0.095	0	150		150	7033TVN2GVVR	7033TVN2GVET	25	
1/4"	5/64 x 5/64	0.14 x 0.14	0	100		100	7033TVN2JVVR	7033TVN2JVET	25	
1/4"	1/8 x 1/8	0.23 x 0.23	0	50		50	7033TVN2NVVR	7033TVN2NVET	25	

* All wetted parts are stainless steel, FKM and plastic.

DIRECT ACTING 316L STAINLESS STEEL VALVES—INTRINSICALLY SAFE, NBR SEALS

Pipe Size NPT	Orifice Size (inch)	Cv Factor	Operating Pressure Differential (PSI)				No-Voltage Release Pressure Vessel Number	Electrically Tripped Pressure Vessel Number	Const. Ref.	
			Min.*	Maximum		10 watt				22 watt
				AC Ratings						
1/4"	3/16	0.53	0			145	U033X51560860N7+	-	25	

+ Includes coil, ref. page 106.

DRAWINGS

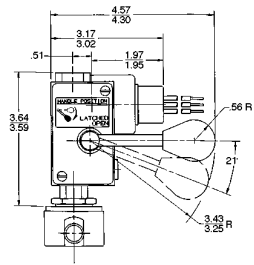

Dimension	No-Voltage Release	Electrically Tripped
A	4.64	4.40
B	4.31	4.07
C	1.79	1.59
D	3.26	3.06



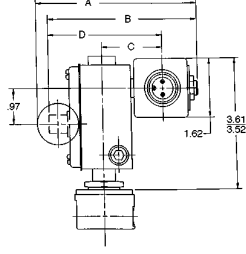

Dimensions apply to Manual Reset feature only.

#25

SKINNER 7000 Series Remote Pressure Operated Three-Way Remote Operated Valves

SPECIFICATIONS

Mechanical Characteristics

Standard Materials of Construction

- Body—Brass
- Diaphragm Seal—NBR/PTFE
- Seals—NBR
- Springs—Stainless Steel (18-8)
- Pilot Orifice—Stainless Steel (303)

Compatible Fluids

- Lubricated Air, Non-Lubricated Air, Inert Gases, Water, Hydraulic Fluids, Petroleum Products and additional fluids compatible with materials of construction.

REMOTE PRESSURE OPERATED VALVES—DUAL PURPOSE

Pipe Size NPT	Orifice Body NC (inch)	Orifice Body NO (inch)	Cv Factor NC	Cv Factor NO	Pressure Vessel Catalog Number	Const. Ref.
3/8"	3/8	3/8	2.1	2.1	75332BN3RN00	47
1/2"	1/2	1/2	3.6	3.6	75332BN4UN00	47
3/4"	3/4	3/4	7.3	7.3	75332BN52N00	48

Note that these valves do not feature an electrical operator, therefore no enclosure and coil selection is necessary.

REMOTE OPERATED VALVE PORT CONNECTIONS

Valve Type	Main Line Supply	Connections For Remote Valve				3-Way Pilot Valve Hookup		
		Normally Closed Port	Normally Open Port	Common Port	Pilot Inlet Port* 1/8" NPT	Normally Closed Port	Normally Open Port	Common Port
Normally Open	0-180 PSIG	Media Exhaust	Media Inlet	Cylinder	Connect to Common Port of 3-Way Pilot	Main Line Pressure +10 PSI Minimum	Pilot Exhaust	1/8" NPT Pilot of Remote Control Valve
	Vacuum	Atmosphere	Vacuum	Cylinder		10 PSI Minimum	Vacuum	
Normally Closed	0-180 PSIG	Media Inlet	Media Exhaust	Cylinder		Main Line Pressure +10 PSI Minimum	Pilot Exhaust	
	Vacuum	Vacuum	Atmosphere	Cylinder		10 PSI Minimum	Vacuum	
Directional Control	0-180 PSIG	Media Outlet	Media Outlet	Media Inlet		Main Line Pressure +10 PSI Minimum	Pilot Exhaust	
	Vacuum	Inlet	Inlet	Vacuum		10 PSIG Minimum	Vacuum	

* To assure long, trouble free life, the Pilot IN to main pressure should not exceed 200 PSIG.

DRAWINGS

Valve	H	P	L	W	S	T	R	J	K
75332BN3RN00	2.43	1.49	2.97	2.62	0.65	0.59	1.44	1.22	0.91
75332BN4UN00	2.67	1.61	3.38	3.09	0.78	0.69	1.66	1.41	1.06

#47

Port Identification:
Pressure can be applied at any port.

#48

Port Identification:
Pressure can be applied at any port.

Three-Way Solenoid Valves

SKINNER 3000 Series Three-Way Direct Acting Valves

SPECIFICATIONS

Mechanical Characteristics

Standard Materials of Construction

- Body—Brass or Stainless Steel (303)
- Seals—NBR, FKM, Ethylene Propylene, CR
- Sleeve Assembly—305 Stainless Steel (tube-flange), 430F Stainless Steel (stop)
- Plunger—430F Stainless Steel
- Manifold Body—Aluminum
- Flux Plate—Plated Steel
- Housing—Plated Steel
- Integrated Coil Encapsulant—Nylon
- Springs - 18-8

Compatible Fluids

- Air, inert gas, water, oil

Vacuum

- Up to 5 microns depending on application

Electrical Characteristics

Voltages

- DC 12, 24
- AC—24, 50/60, 110/50-120/60, 220/50-240/60

Power Consumption

- 6 watts, 7.5 for 24/60
- 3 watts

Agency Approvals

- UL and CSA component recognition.

Miscellaneous

Maximum Ambient Temperature

- 68°F for continuous duty cycle.

Response Time

- 8 to 16 milliseconds to open or close.

Duty Cycle

- Continuous duty, 600 cycles per minute.

Weight

- 8 oz.

Mounting

- Two 8-32 tapped holes in bottom of valve body supplied standard. A universal mounting bracket B19-006 is also available. See page 68

DIRECT ACTING BRASS AND STAINLESS STEEL VALVES—NORMALLY CLOSED

Pipe Size NPT	Body Orifice Size (inch)	Body Cv Factor	Sleeve Orifice Size (inch)	Sleeve Cv Factor	Maximum Operating Pressure Differential (PSI)		Brass Pressure Vessel Catalog Number	Stainless Steel Pressure Vessel Catalog Number
					6 watt	3 watt*		
1/8"	1/32	0.03	1/32	0.03	200	-	3131BBN1AN00	3131BSN1AN00
	3/64	0.05	3/64	0.05	150	-	3131BBN1EN00	3131BSN1EN00
	1/16	0.09	1/16	0.09	100	-	3131BBN1GN00	3131BSN1GN00
	5/64	0.13	1/16	0.09	80	50	3131BBN1JN00	3131BSN1JN00
	3/32	0.18	1/16	0.09	60	35	3131BBN1LN00	3131BSN1LN00
	1/8	0.24	1/16	0.09	40	20	3131BBN1NN00	3131BSN1NN00
	5/32	0.30	1/16	0.09	10	10	3131BBN1QN00	3131BSN1QN00

DIRECT ACTING BRASS AND STAINLESS STEEL VALVES—NORMALLY OPEN

Pipe Size NPT	Body Orifice Size (inch)	Body Cv Factor	Sleeve Orifice Size (inch)	Sleeve Cv Factor	Maximum Operating Pressure Differential (PSI)		Brass Pressure Vessel Catalog Number	Stainless Steel Pressure Vessel Catalog Number
					6 watt	3 watt*		
1/8"	1/32	0.03	1/32	0.03	160	-	3139BBN1AN00	3139BSN1AN00
	3/64	0.05	3/64	0.05	125	-	3139BBN1EN00	3139BSN1EN00
	1/16	0.09	1/16	0.09	100	-	3139BBN1GN00	3139BSN1GN00
	5/64	0.13	1/16	0.09	80	-	3139BBN1JN00	3139BSN1JN00
	3/32	0.18	1/16	0.09	60	-	3139BBN1LN00	3139BSN1LN00
	1/8	0.24	1/16	0.09	40	-	3139BBN1NN00	3139BSN1NN00
	5/32	0.30	1/16	0.09	10	-	3139BBN1QN00	3139BSN1QN00

DIRECT ACTING BRASS AND STAINLESS STEEL VALVES—MULTIPURPOSE

Pipe Size NPT	Body Orifice Size (inch)	Body Cv Factor	Sleeve Orifice Size (inch)	Sleeve Cv Factor	Maximum Operating Pressure Differential (PSI)		Brass Pressure Vessel Catalog Number	Stainless Steel Pressure Vessel Catalog Number
					6 watt	3 watt*		
1/8"	1/32	0.03	1/32	0.03	150	95	3133BBN1AN00	3133BSN1AN00
	3/64	0.05	3/64	0.05	100	60	3133BBN1EN00	3133BSN1EN00
	1/16	0.09	1/16	0.09	80	20	3133BBN1GN00	3133BSN1GN00
	5/64	0.13	1/16	0.09	60	8	3133BBN1JN00	3133BSN1JN00
	3/32	0.18	1/16	0.09	35	-	3133BBN1LN00	3133BSN1LN00
	1/8	0.24	1/16	0.09	20	-	3133BBN1NN00	3133BSN1NN00
	5/32	0.30	1/16	0.09	10	-	3133BBN1QN00	3133BSN1QN00

3000 Series Three-Way Direct Acting Valves

DIRECT ACTING BRASS AND STAINLESS STEEL VALVES—DIRECTIONAL CONTROL

Pipe Size NPT	Body Orifice Size (inch)	Body Cv Factor	Sleeve Orifice Size (inch)	Sleeve Cv Factor	Maximum Operating Pressure Differential (PSI)		Brass Pressure Vessel Catalog Number	Stainless Steel Pressure Vessel Catalog Number
					6 watt	3 watt*		
1/8"	1/32	0.03	1/32	0.03	230	-	3138BBN1AN00	3138BSN1AN00
	3/64	0.05	3/64	0.05	160	-	3138BBN1EN00	3138BSN1EN00
	1/16	0.09	1/16	0.09	120	-	3138BBN1GN00	3138BSN1GN00
	5/64	0.13	1/16	0.09	80	-	3138BBN1JN00	3138BSN1GN00
	3/32	0.18	1/16	0.09	60	-	3138BBN1LN00	3138BSN1LN00
	1/8	0.24	1/16	0.09	35	-	3138BBN1NN00	3138BSN1NN00
	5/32	0.30	1/16	0.09	20	-	3138BBN1QN00	3138BSN1QN00

Performance Ratings Apply to All Voltages, Coil Constructions, Seal and Body Materials.

* When ordering a pressure vessel with a 3 watt coil the second digit must be a 9. Example: 3931BBN1JN00 is a 3-way normally closed pressure vessel for use with 3 watt coils.

MANIFOLD ASSEMBLED VALVES—NORMALLY CLOSED, COMMON INLET PRESSURE UNDER SEAT

Body Orifice Size (inch)	Body Cv Factor	Sleeve Orifice Size (inch)	Sleeve Cv Factor	Maximum Operating Pressure Differential (PSI)		Cavity Manifold Assembly Catalog Number	Screw-In Manifold Assembly Catalog Number
				6 watt	3 watt*		
3/64	0.05	3/64	0.05	150	-	3131BJA7ENC#	3131BSA6EN00
1/16	0.09	1/16	0.09	100	-	3131BJA7GNC#	3131BSA6GN00
1/8	0.24	1/16	0.09	40	20	-	3131BSA6NN00
5/32	0.30	1/16	0.09	10	10	-	3131BSA6QN00

MANIFOLD ASSEMBLED VALVES—NORMALLY OPEN, COMMON INLET PRESSURE UNDER SEAT

Body Orifice Size (inch)	Body Cv Factor	Sleeve Orifice Size (inch)	Sleeve Cv Factor	Maximum Operating Pressure Differential (PSI)		Cavity Manifold Assembly Catalog Number	Screw-In Manifold Assembly Catalog Number
				6 watt	3 watt*		
3/64	0.05	3/64	0.05	125	-	3139BJA7ENC#	3139BSA6EN00
1/16	0.09	1/16	0.09	100	-	3139BJA7GNC#	3139BSA6GN00
1/8	0.24	1/16	0.09	40	-	-	3139BSA6NN00
5/32	0.30	1/16	0.09	10	-	-	3139BSA6QN00

MANIFOLD ASSEMBLED VALVES—MULTIPURPOSE, COMMON INLET PRESSURE UNDER SEAT

Body Orifice Size (inch)	Body Cv Factor	Sleeve Orifice Size (inch)	Sleeve Cv Factor	Maximum Operating Pressure Differential (PSI)		Cavity Manifold Assembly Catalog Number	Screw-In Manifold Assembly Catalog Number
				6 watt	3 watt*		
3/64	0.05	3/64	0.05	100	60	3133BJA7ENC#	3133BSA6EN00
1/16	0.09	1/16	0.09	80	20	3133BJA7GNC#	3133BSA6GN00
1/8	0.24	1/16	0.09	20	-	-	3133BSA6NN00
5/32	0.30	1/16	0.09	10	-	-	3133BSA6QN00

MANIFOLD ASSEMBLED VALVES—DIRECTIONAL CONTROL, COMMON INLET PRESSURE OVER SEAT

Body Orifice Size (inch)	Body Cv Factor	Sleeve Orifice Size (inch)	Sleeve Cv Factor	Maximum Operating Pressure Differential (PSI)		Cavity Manifold Assembly Catalog Number	Screw-In Manifold Assembly Catalog Number
				6 watt	3 watt*		
3/64	0.05	3/64	0.05	160	-	3138BJA7ENC#	3138BSA6EN00
1/16	0.09	1/16	0.09	120	-	3138BJA7GNC#	3138BSA6GN00
1/8	0.24	1/16	0.09	35	-	-	3138BSA6NN00
5/32	0.30	1/16	0.09	20	-	-	3138BSA6QN00

* When ordering a pressure vessel with a 3 watt coil the second digit must be a 9. Example: 3931BSA6NN00 is a 3-way normally closed pressure vessel for use with 3 watt coils. Performance Ratings Apply to All Voltages, Coil Constructions, Seal and Body Materials. Screw-in body available in stainless steel only.

Note: Integrated coils not suitable for manifold mount valved.

Denotes the number of valves in the manifold, from 2 to 4. Screw-in manifolds and valves sold separately.

Fittings #V1-22-028 available to join manifolds when more than 4 stations required.

3000 Series Three-Way Direct Acting Valves

Technical drawing of valve #27 showing cross-section, side view, and port identification table.

Port Identification

Ports	3131	3139	3133	3138
1	IN	Exhaust	NC	NC
2	Cylinder	Cylinder	Common	IN
3	Exhaust	IN	No	NO

#27

Technical drawing of valve #28 showing cross-section, side view, and port identification table.

Port Identification

Ports	3131	3139	3133	3138
1	IN	Exhaust	NC	NC
2	Cylinder	Cylinder	Common	IN
3	Exhaust	IN	No	NO

#28

Three-Way Solenoid Valves

Screw-In Manifolds	Common Port	Pressure Direction	Number of Stations		
			2	3	4
3WNC (3131)	Inlet	Under Seat	300-40-022	300-40-023	300-40-024
3WDIR (3138)	Common	Over Seat	300-40-015	300-40-016	300-40-017

SKINNER B-Series General Purpose Three-Way Direct Acting Valves

SPECIFICATIONS

Mechanical Characteristics

Standard Materials of Construction

- Body—Stainless Steel (303)
- Seals—FKM
- Sleeve—304 Stainless Steel
- Plunger—430F Stainless Steel
- Stop—430 FR Stainless Steel
- Springs—Stainless Steel (18-8)
- Shading Ring—Copper (AC only)
- Orifice 303 Stainless Steel

Compatible Fluids

- Lubricated Air, Non-Lubricated Air, Inert Gases, Water, Steam, Hydraulic Fluids, Petroleum Products, Freons, and additional fluids compatible with materials of construction.

Minimum Operating Pressure Differential

- 0 PSI

Electrical Characteristics

Voltages

- DC—12, 24
- AC—24/60, 120/60, 240/60 (other voltages available upon request)

Power Consumption

- 7 watts

Ordering B Series Valves:

Example:

- 1) Specify the valve catalog number-B13DK1100
- 2) Specify the required voltage-120V, 60Hz

Miscellaneous

Vacuum

- Down to 5 microns (0.005 torr, 2x10⁻⁴ in Hg)

Operating Speed

- Up to 800 cycles per minute

Response Time

- AC—Approximately 4-8 milliseconds to open or close.
- DC—Approximately 10-15 milliseconds to open, 6-12 milliseconds to close.

Accessories

- Universal Mounting Bracket (B19-006)
- Wrench nut (B99-007)

B13 DIRECT ACTING STAINLESS STEEL VALVES—NORMALLY CLOSED, FKM SEALS

Pipe Size	Orifice Diameter		Cv Factor		Maximum Operating Pressure Differential (PSI) (AC & DC)	Class A Taped Coil Grommet Enclosure	Const. Ref.
	Inlet Port	Exh. Port	Inlet Port	Exh. Port			
1/8" NPT	1/32	1/32	0.019	0.019	200	B13DK1200	132
	3/64	3/64	0.048	0.052	150	B13DK1150	132
	1/16	3/64	0.085	0.052	100	B13DK1100	132
	3/32	3/32	0.16	0.13	40	B13DK1040	132

B13A DIRECT ACTING STAINLESS STEEL VALVES—NORMALLY CLOSED EXHAUST TO ATMOSPHERE, FKM SEALS

1/8" NPT	1/32	1/32	0.019	0.019	200	B13ADK1200	133
	3/64	3/64	0.048	0.052	150	B13ADK1150	133
	1/16	3/64	0.085	0.052	100	B13ADK1100	133
	3/32	3/32	0.16	0.13	40	B13ADK1040	133

B14 DIRECT ACTING STAINLESS STEEL VALVES—MULTIPURPOSE, FKM SEALS

1/8" NPT	1/32	1/32	0.019	0.019	150	B14DK1150	132
	3/64	3/64	0.048	0.052	100	B14DK1100	132
	1/16	3/64	0.085	0.052	75	B14DK1075	132
	3/32	3/32	0.16	0.13	30	B14DK1030	132

B15 DIRECT ACTING STAINLESS STEEL VALVES—NORMALLY OPEN, FKM SEALS

1/8" NPT	1/32	1/32	0.019	0.019	200	B15DK1200	132
	3/64	3/64	0.052	0.048	150	B15DK1150	132
	3/64	1/16	0.052	0.085	125	B15DK1125	132
	3/32	3/32	0.16	0.13	40	B15DK1040	132

B16 DIRECT ACTING STAINLESS STEEL VALVES—DIRECTIONAL CONTROL, FKM SEALS

1/8" NPT	1/32	1/32	0.019	0.019	250	B16DK1250	132
	3/64	3/64	0.048	0.052	200	B16DK1200	132
	1/16	3/64	0.085	0.052	175	B16DK1175	132
	3/32	3/32	0.16	0.13	50	B16DK1050	132

B-Series General Purpose Three-Way Direct Acting Valves

DRAWINGS

1/4" CONDUIT OR GROMMET ARE OPTIONS

#8-32 NC-2B TH'D
2 PLC'S

Port Identification:			
B13	B14	B15	B16
1-IN	NC	Exhaust	NC
2-Cylinder	Common	Cylinder	IN
3-Exhaust	NO	IN	NO

#132

1/4" CONDUIT OR GROMMET ARE OPTIONS

#8-32 NC-2B TH'D
2 PLC'S

Port Identification:	
B13	2
1-IN/ 2-Cylinder/ 3*-Exhaust	(* not marked)

#133

Three-Way Solenoid Valves

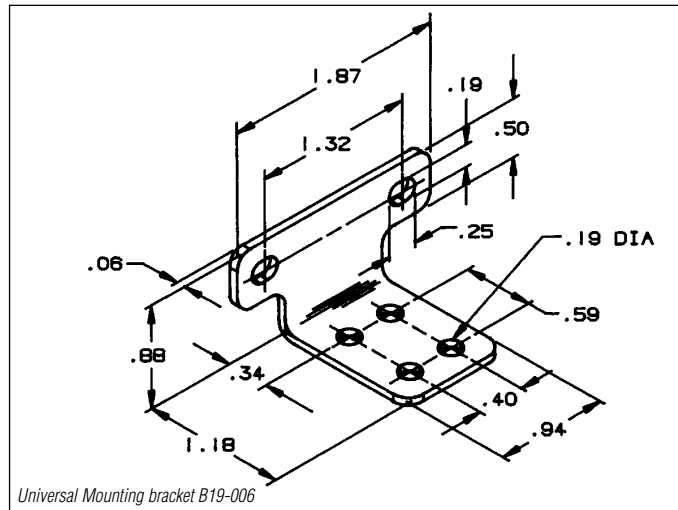

SKINNER C-Series General Purpose Three-Way Direct Acting Valves

SPECIFICATIONS

Mechanical Characteristics

Standard Materials of Construction

- Body—Brass (Stainless Steel available)
- Seals—FKM, EPDM available
- Sleeve—304 Stainless Steel
- Plunger—430FR Stainless Steel
- Stop—430 FR Stainless Steel
- Springs—Stainless Steel (18-8)
- Shading Ring—Copper (AC only)
- Orifice—Brass, Stainless Steel

Compatible Fluids

- Lubricated Air, Non-Lubricated Air, Inert Gases, Water, Steam, Hydraulic Fluids, Petroleum Products and additional fluids compatible with materials of construction. Note: Use with Steam and some Petroleum Products may require plunger seal material modification.

Consult Fluid Control Division to specify a suitable material.

Minimum Operating Pressure Differential

- 0 PSI

Electrical Characteristics

Voltages

- DC—12, 24
- AC—24/60, 120/60, 240/60

Power Consumption

- 8 watts

Agency Approvals

- UL and CSA approvals are generally available on valves with applicable coil/enclosure combinations. For details consult Fluid Control Division.

Miscellaneous

Vacuum

- Down to 5 microns (0.005 torr, 2x10⁻⁴ in Hg)

Operating Speed

- Up to 600 cycles per minute

Response Time

- AC—Approximately 4-8 milliseconds to open or close.
- DC—Approximately 10-15 milliseconds to open, 6-12 milliseconds to close.

Ordering C Series Valves:

Example:

- 1) Specify the valve catalog number-C4DK1052
- 2) Specify the required voltage-120V, 60Hz

C3 DIRECT ACTING BRASS VALVES—NORMALLY CLOSED, FKM SEALS

NPT Pipe Size	Orifice Diameter		Cv Factor		Maximum Operating Pressure Differential (PSI)		Class A Taped Coil		Const. Ref.
	Inlet Port	Exh. Port	Inlet Port	Exh. Port	AC	DC	Grommet Enclosure	1/2" NPT Conduit	
							C3DK1175	C3DM1175	
1/8"	3/64	1/16	0.05	0.09	175	175	C3DK1125	C3DM1125	51
	1/16	1/16	0.09	0.09	125	125	C3DK1075	C3DM1075	51
	3/32	3/32"	0.18	0.18	75	75	C3DK1050	C3DM1050	51
	1/8	3/32	0.26	0.18	50	50			

C3A DIRECT ACTING BRASS VALVES—NORMALLY CLOSED EXHAUST TO ATMOSPHERE, FKM SEALS

NPT Pipe Size	Orifice Diameter		Cv Factor		Maximum Operating Pressure Differential (PSI)		Class A Taped Coil		Const. Ref.
	Inlet Port	Exh. Port	Inlet Port	Exh. Port	AC	DC	Grommet Enclosure	1/2" NPT Conduit	
							C3ADK1175	C3ADM1175	
1/8"	3/64	1/16	0.05	0.09	175	175	C3ADK1125	C3ADM1125	52
	1/16	1/16	0.09	0.09	125	125	C3ADK1075	C3ADM1075	52
	3/32	3/32	0.18	0.18	75	75	C3ADK1050	C3ADM1050	52
	1/8"	3/32	0.26	0.18	50	50			

C4 DIRECT ACTING BRASS VALVES—MULTIPURPOSE, FKM SEALS

NPT Pipe Size	Orifice Diameter		Cv Factor		Maximum Operating Pressure Differential (PSI)		Class A Taped Coil		Const. Ref.
	Inlet Port	Exh. Port	Inlet Port	Exh. Port	AC	DC	Grommet Enclosure	1/2" NPT Conduit	
							C4DK1150	C4DM1150	
1/8"	3/64	3/64	0.05	0.05	150	150	C4DK1075	C4DM1075	51
	1/16	1/16	0.09	0.09	75	75	C4DK1052	C4DM1052	51
	3/32	3/32	0.18	0.18	50	-	C4DK1031	C4DM1031	51
	3/32	3/32	0.18	0.18	-	30			

C5 DIRECT ACTING BRASS VALVES—NORMALLY OPEN, FKM SEALS

NPT Pipe Size	Orifice Diameter		Cv Factor		Maximum Operating Pressure Differential (PSI)		Class A Taped Coil		Const. Ref.
	Inlet Port	Exh. Port	Inlet Port	Exh. Port	AC	DC	Grommet Enclosure	1/2" NPT Conduit	
							C5DK1175	C5DM1175	
1/8"	3/64	1/16	0.05	0.09	175	175	C5DK1100	C5DM1100	51
	1/16	3/32	0.09	0.15	100	100	C5DK1060	C5DM1060	51
	3/32	1/8	0.18	0.26	60	60			

C-Series General Purpose Three-Way Direct Acting Valves

Valve Accessories

Accessories	Part No.
Universal mounting bracket	MECHB5
Wrench nut	V0-233
Metered exhaust adapter (air only-type C3 valves)	V5-1024

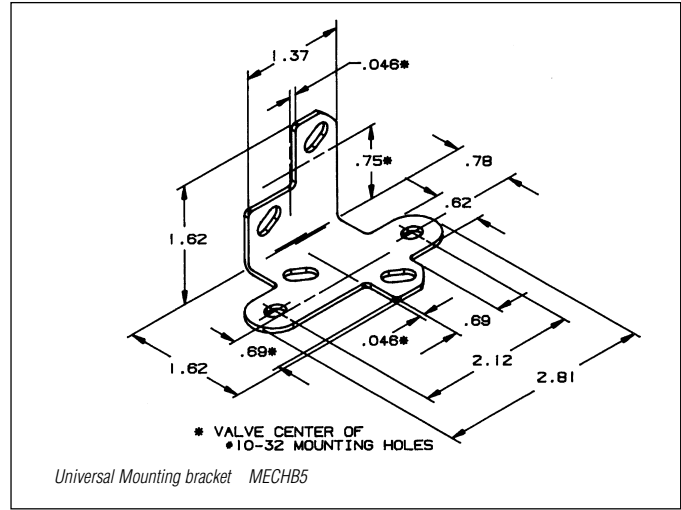

DRAWINGS

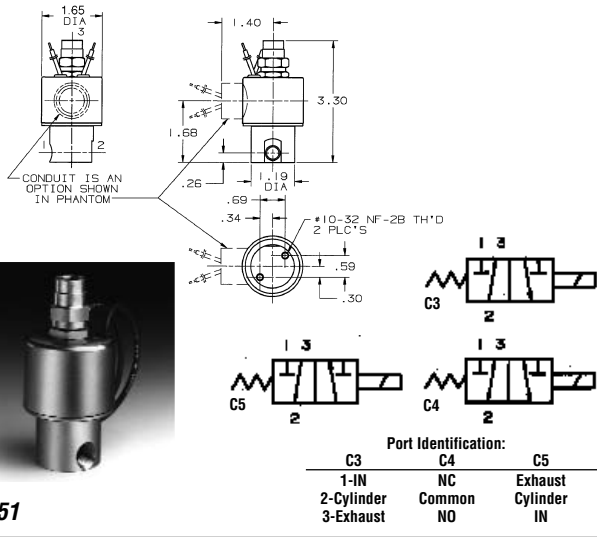

#51

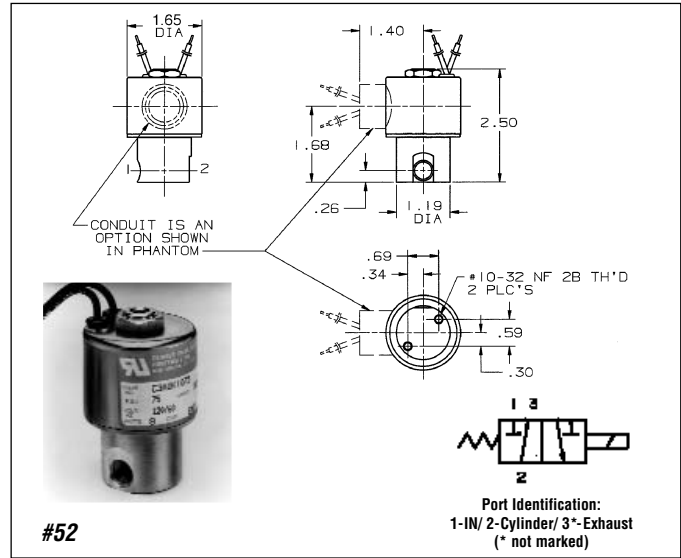

#52

Three-Way Solenoid Valves

SKINNER A-Series General Purpose Three-Way Direct Acting Valves

SPECIFICATIONS

Mechanical Characteristics

Standard Materials of Construction

- Body—Brass
- Seals—NBR
- Sleeve—304 Stainless Steel
- Plunger—430FR Stainless Steel
- Stop—430 FR Stainless Steel
- Springs—Stainless Steel (18-8)
- Shading Ring—Copper (AC only)
- Orifice—Stainless Steel (303)

Compatible Fluids

- Lubricated Air, Non-Lubricated Air, Oils, Inert Gases, and additional fluids compatible with materials of construction.

Minimum Operating Pressure Differential

- 0 PSI

Pipe Sizes

- 1/8" NPT dry seal.

Electrical Characteristics

Voltages

- DC—12, 24, 120
- AC—24/60, 120/60, 240/60 (other voltages available upon request)

Power Consumption

- 16 watts AC, 14 watts DC

Miscellaneous

Vacuum

- Down to 5 microns (0.005 torr, 2x10⁻⁴ in Hg)

Operating Speed

- Up to 300 cycles per minute

Response Time

- AC—Approximately 4-8 milliseconds to open or close.
- DC—Approximately 10-15 milliseconds to open, 6-12 milliseconds to close.

Ordering A Series Valves:

Example:

- 1) Specify the valve catalog number-A36LB2251
- 2) Specify the required voltage-12 VDC

A3 DIRECT ACTING VALVES—NORMALLY CLOSED, NBR SEALS

Pipe Size		Orifice Diameter		Cv Factor	Maximum Operating Pressure Differential (PSI)		Class B Molded 1/2" NPT Conduit	Const. Ref.
Body NPT	Sleeve NPT	Inlet Port	Outlet Port		AC	DC		
1/4"	1/8	3/32	3/32	0.21	250	-	A3LB2252	53
		3/32	3/32	0.21	-	250	A36LB2251	53
		1/8	1/8	0.35	175	-	A3LB2177	53
		1/8	1/8	0.35	-	175	A36LB2176	53
		5/32	5/32	0.45	125	-	A3LB2127	53
		5/32	5/32	0.45	-	125	A36LB2126	53

A4 DIRECT ACTING VALVES—MULTIPURPOSE, NBR SEALS

Pipe Size		Orifice Diameter		Cv Factor	Maximum Operating Pressure Differential (PSI)		Class B Molded 1/2" NPT Conduit	Const. Ref.
Body NPT	Sleeve NPT	Inlet Port	Outlet Port		AC	DC		
1/4"	1/8	3/32	3/32	0.21	150	-	A4LB2152	53
		3/32	3/32	0.21	-	150	A46LB2151	53
		1/8	1/8	0.35	100	-	A4LB2102	53
		1/8	1/8	0.35	-	100	A46LB2101	53
		5/32"	5/32	0.45	75	-	A4LB2077	53
		5/32	5/32	0.45	-	75	A46LB2076	53

A5 DIRECT ACTING VALVES—NORMALLY OPEN, NBR SEALS

Pipe Size		Orifice Diameter		Cv Factor	Maximum Operating Pressure Differential (PSI)		Class B Molded 1/2" NPT Conduit	Const. Ref.
Body NPT	Sleeve NPT	Inlet Port	Outlet Port		AC	DC		
1/4"	1/8	3/32	3/32	0.21	250	-	A5LB2252	53
		3/32	3/32	0.21	-	250	A56LB2251	53
		1/8	1/8	0.35	175	-	A5LB2177	53
		1/8	1/8	0.35	-	175	A56LB2176	53
		5/32	5/32	0.45	125	-	A5LB2127	53
		5/32	5/32	0.45	-	125	A56LB2126	53

A-Series General Purpose Three-Way Direct Acting Valves

A6 DIRECT ACTING VALVES—DIRECTIONAL CONTROL, NBR SEALS

Pipe Size		Orifice Diameter		Cv Factor	Maximum Operating Pressure Differential (PSI)		Class B Molded 1/2" NPT Conduit	Const. Ref
Body NPT	Sleeve NPT	Inlet Port	Outlet Port		AC	DC		
1/4"	1/8	3/32	3/32	0.21	250	-	A6LB2252	53
		3/32	3/32	0.21	-	250	A66LB2251	53
		1/8	1/8	0.35	175	-	A6LB2177	53
		1/8	1/8	0.35	-	175	A66LB2176	53
		5/32	5/32	0.45	125	-	A6LB2127	53
		5/32	5/32	0.45	-	125	A66LB2126	53

Three-Way Solenoid Valves

DRAWINGS

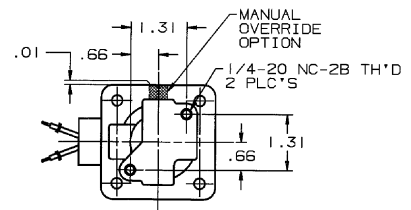
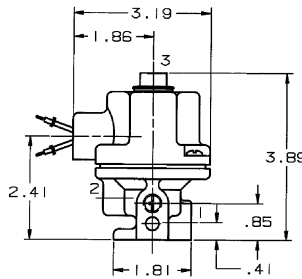
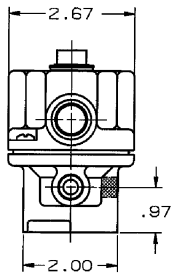

#53

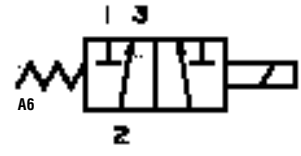
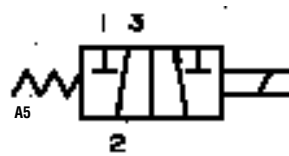
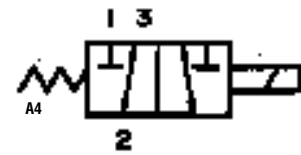
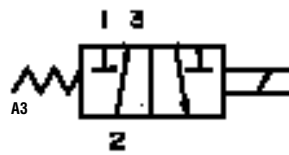

Port Identification:

	A3	A4	A5	A6
P	IN	NC	Exhaust	NC
A	Cylinder	Common	Cylinder	IN
E	Exhaust	NO	IN	NO

Four-Way Valve

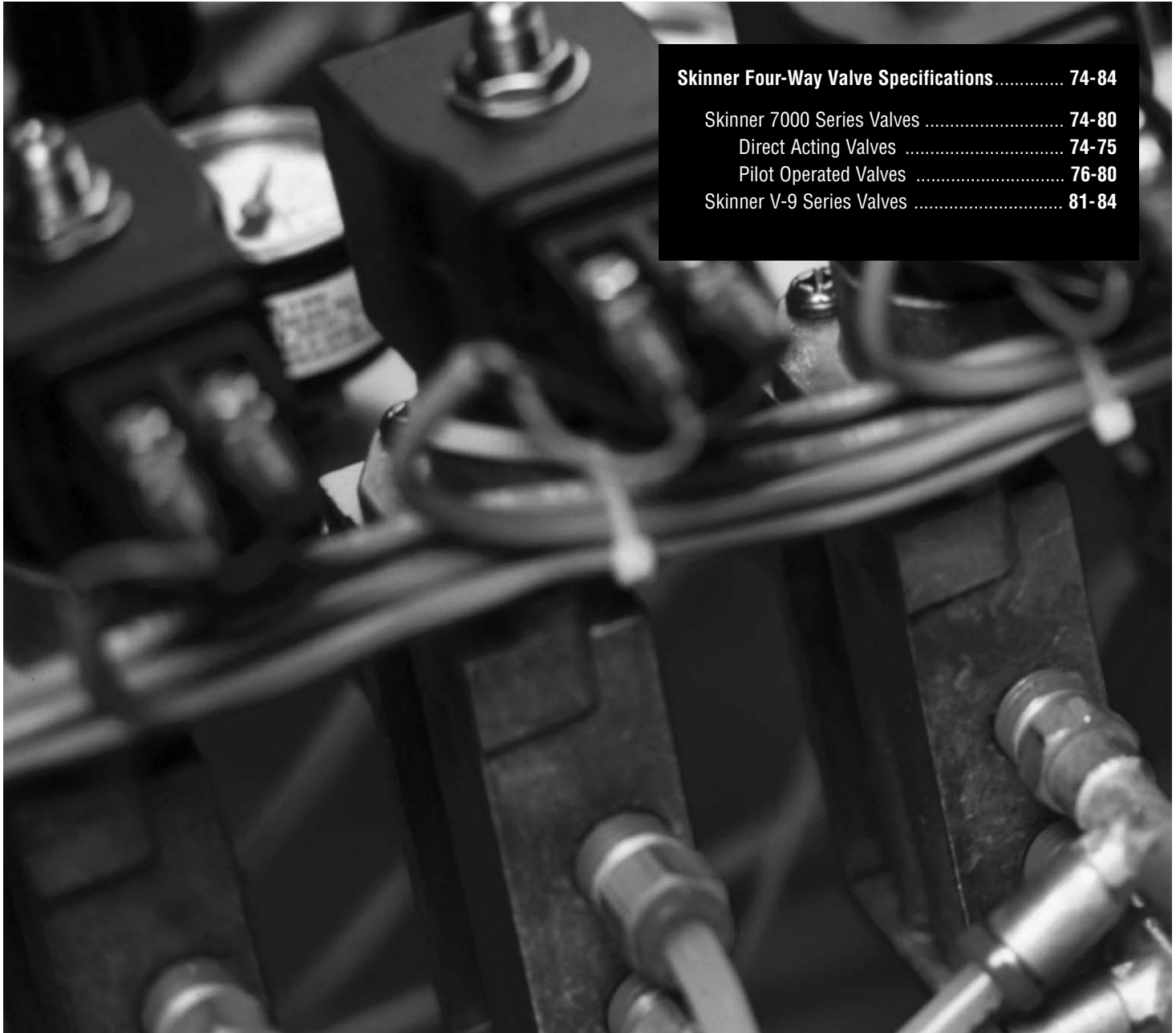



Series 71417 & 71477 - 4-way Direct Acting Solenoid Valves

VALVE FEATURES

- Direct Acting Operation
- Dual Frequency Rated Coils
- Available Locking Manual Override
- Optional Flow Control Regulates Cylinder Speed Independently
- Dual Solenoid Operation – holds last position, even after loss of power, pneumatics or pressure
- Mountable in any position
- Long Life Operator

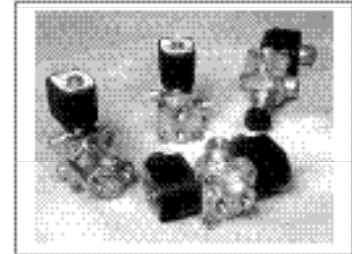

Mechanical Characteristics

Standard Materials of Construction.

- Body: Brass
- Seals: NBR
- Plunger: 430FR Stainless
- Sleeve Tube: 304 SS
- Stop: 430FR Stainless
- Springs: Stainless
- Shading Ring: Copper
- Seats: Engineered PTFE
- Guide: Engineered Polyamide Thermoplastic

Electrical Characteristics

Voltages:

AC – 24/60, 110/50-120/60
220/50-240/60

Agency Approvals:

UL and CSA approvals are available with applicable coil/enclosure combinations

Miscellaneous

Minimum Ambient Temperatures:

- 32°F

Maximum Ambient Temperatures:

- 24 watt AC – 140°F

Compatible Fluids:

Lubricated Air, Inert Gases, Water.
Use of non-lubricated gaseous media will substantially limit valve life.

AC VALVE SPECIFICATIONS: (English Units)

NPT Pipe Size	Orifice Dia. Inch	Cv*	Min (psi)	Max. MOPD			Max. Fluid Temp. °F	AC Watt	Pressure Vessel Part Number (1)
				Air, Inert Gas (psi)	Water (psi)	Lt. Oil 300 SSU (psi)			
Single Solenoid									
1/4	3/16	0.75	0	125	125	125	160	24	71417BN2SN00
3/8	3/16	0.75	0	125	125	125	160	24	71417BN3SN00
Dual Solenoid									
1/4	3/16	0.75	0	125	125	125	160	24	71477BN2SN00
3/8	3/16	0.75	0	125	125	125	160	24	71477BN3SN00

(1) Reference Table for Part Numbers with Optional Features

* Cv is 0.45 with built-in metering control (R1 & MR options)

AC VALVE SPECIFICATIONS: (Metric Units)

NPT Pipe Size	Orifice Dia. mm	Kv	Min (bar)	Max. MPOD			Max. Fluid Temp. °C	AC Watt	Pressure Vessel Part Number (1X2)
				Air, Inert Gas (bar)	Water (bar)	Lt. Oil 300 SSU (bar)			
Single Solenoid									
1/4	4.75	0.65	0	8.6	8.6	8.6	71	24	71417BN2SN00
3/8	4.75	0.65	0	8.6	8.6	8.6	71	24	71417BN3SN00
Dual Solenoid									
1/4	4.75	0.65	0	8.6	8.6	8.6	71	24	71477BN2SN00
3/8	4.75	0.65	0	8.6	8.6	8.6	71	24	71477BN3SN00

(1) Reference Table for Part Numbers with Optional Features

Valve Numbers with Optional Features:

Optional Features	Part Number 1/4" NPT porting	Part Number 3/8" NPT porting
Single Solenoid		
Manual Operator	71417BN2SNM0	71417BN3SNM0
Metering	71417BN2SNR1	71417BN3SNR1
Metering & Manual Operator	71417BN2SNMR	71417BN3SNMR
Dual Solenoid		
Metering	71477BN2SNR1	71477BN3SNR1

Electrical Selection Guide

Coil/ Enclosure	Class	Wattage	Description
C8GL	H	24	Conduit, NEMA 4x
H8GL	H	24	Hazardous, NEMA 4X, 7, 9
D800	H	24	DIN

Electrical Information

Voltage Code	Voltage	VA Holding	VA Inrush
B2	24/60	38.3	76.0
P3	120/60, 110/60	38.3	76.0
Q3	240/60, 220/60	38.3	76.0

Valve Ordering

- Select pressure vessel number.
- Add "N0" for nut & washer enclosure.
- Select 4-digit coil.
- Select 2-digit voltage code.

Example: To order 1/4" NPT pressure vessel, single solenoid, hazardous coil, 120/60 with manual override.
 71417BN2SNM0+N0+H8GL+P3 = 71417BN2SNM0N0H8GLP3
 To order the pressure vessel alone, select only the pressure vessel number.
 To select coil alone, select 4-digit coil part and 2-digit voltage code.

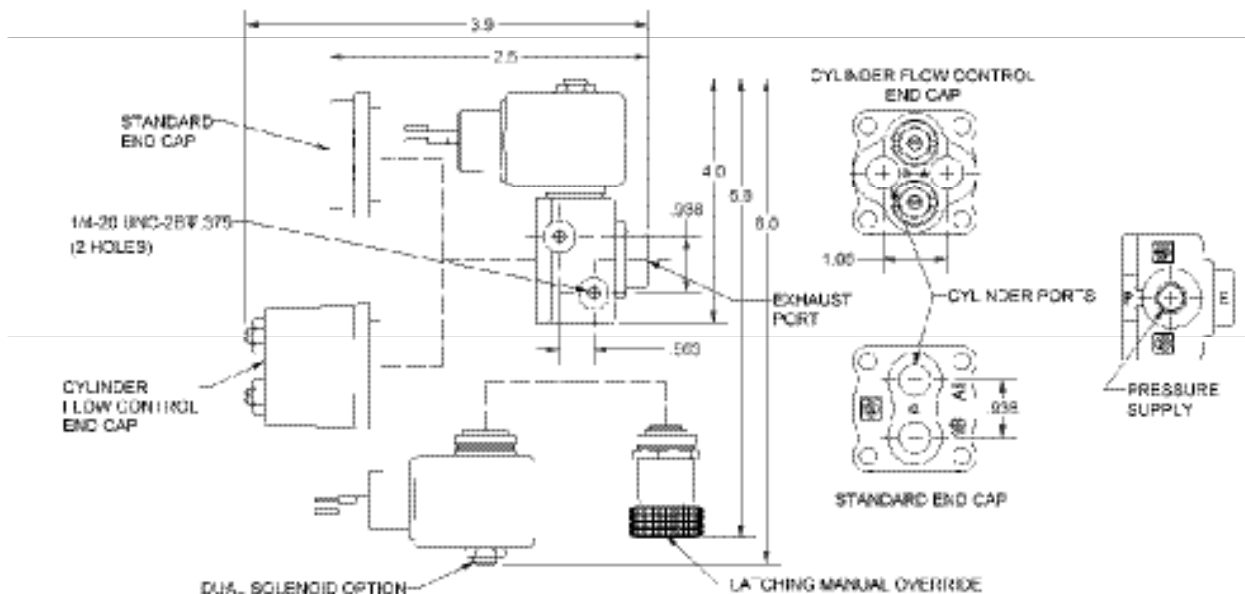

SKINNER 7000 Series General Purpose Four-Way Pilot Operated Valves

SPECIFICATIONS

Mechanical Characteristics

Standard Materials of Construction

- Body—Aluminum Alloy, Zinc Alloy (epoxy coated)
- Seals—NBR
- Sleeve Tube—Stainless Steel (303)
- Plunger—Stainless Steel (430FR)
- Stop—Stainless Steel (430FR)
- Springs—Stainless Steel (18-8)
- Shading Rings—Copper
- Pilot Orifice—Stainless Steel (303)

Compatible Fluids

- Lubricated Air, Non-Lubricated Air, Inert Gases.
Use of non-lubricated gaseous media will substantially limit valve life.

Agency Approval

- UL and CSA approvals are available on valves with applicable coil/enclosure combinations. For additional information see page 122.

Electrical Characteristics

Voltages

- DC—12, 24
- AC—24/60, 110/50-120/60, 220/50-240/60, (other AC/DC voltages available upon request)

Miscellaneous

Maximum Ambient Temperature

- 10 watt AC/DC—150°F
- 22 watt AC/DC—77°F
- Fluxtron/Magnelatch—122°F

7341 PILOT OPERATED VALVES—NBR SEALS

Pipe Size NPT	Orifice Size (inch)	Cv Factor	Operating Pressure Differential (PSI)				MAX. Fluid Temp. (F)	Pressure Vessel Number	UL/CSA* Approval	Const. Ref.
			Maximum							
			Min.	AC Ratings		DC Ratings				
10 watt	22 watt	10 watt		22 watt						
1/8"	5/32	0.35	15	150	150	165	7341LAN1HNMO	GP	54	
1/4"	5/16	1.4	15	150	150	165	7341LMN2NNMO	GP	55	

* GP=General Purpose Valves. See page 122 for additional agency approval information.

DRAWINGS

#54

Port Identification:
 Pressure Cyl. A Exh. A Cyl. B Exh. B
 1 2 3 4 5

#55

Port Identification:
 Pressure Cyl. A Exh. A Cyl. B Exh. B
 1 2 3 4 5

SKINNER 7000 Series General Purpose Four-Way Pilot and Manually Operated Valves

SPECIFICATIONS

Mechanical Characteristics

Standard Materials of Construction

- Body—Aluminum
- Seals—NBR
- Spool—Aluminum
- Sleeve Tube—Stainless Steel (304)
- Plunger—Stainless Steel (430FR)
- Stop—Stainless Steel (430FR)
- Springs—Stainless Steel (18-8)
- Shading Rings—Copper

Compatible Fluids

- Lubricated Air, Non-Lubricated Air, Inert Gases.
- Use of non-lubricated gaseous media will substantially limit valve life.

Electrical Characteristics

Voltages

- DC—12, 24
- AC—24/60, 110/50-120/60, 220/50-240/60, (other AC/DC voltages available upon request)

Agency Approval

- UL and CSA approvals are available on valves with applicable coil/enclosure combinations. For additional information see page 122.

Miscellaneous

Maximum Ambient Temperature

- 10 watt AC/DC—150°F
- 22 watt AC/DC—77°F
- Fluxtron/Magnelatch—122°F
- Internal Leakage - 8cc/min max

7341 PILOT OPERATED ALUMINUM SOLENOID OPERATED VALVES—NBR SEALS

Pipe Size NPT	Orifice Size (inch)	Cv Factor	Operating Pressure Differential (PSI)				MAX. Fluid Temp. (F)	Pressure Vessel Number	UL/CSA** Approval	Const. Ref.
			Maximum							
			Min.*	AC Ratings		DC Ratings				
1/4"	1/4	1	30	150	150		165	73419AN2NN00	GP	56
	1/4	1	30	150	150		165	73419AN2NNM0	GP	56

** GP=General Purpose Valves. See page 122 for additional agency approval information.

7541 REMOTE AIR PILOT OPERATED ALUMINUM VALVE—NBR SEALS

Pipe Size NPT	Orifice Size (inch)	Cv Factor	Operating Pressure Differential (PSI)		Pressure Vessel Number	Const. Ref.
			Min.	Max.		
1/4"	1/4	1	*	150	75419AN2NN00	57

* Remote pilot pressure to operate the valve = 20 PSI + 1/3 (main line pressure)

DRAWINGS

#56

Port Identification:
Pressure Cyl. A Exh. A Cyl. B Exh. B
P A EA B EB

#57

Port Identification:
Pressure Cyl. A Exh. A Cyl. B Exh. B
P A EA B EB

Hand Lever Operated Valves

Two-position spool valves are available with no spring return, spring return with cylinder A port open, or spring return with cylinder B port open. Spring return models require the operator to move the handle in one direction and hold it to provide the function. The no-

spring model will remain in either position without holding.

A three-position spool valve is available with all ports closed in its normal position. The handle is moved and held in one

direction to open one cylinder port and to the opposite direction to open the other cylinder port. The spool is spring centered and the handle is normally in the center or upright position.

Types of Operation

Valve 76419AN2NNCB: Two-position, Spring Return, cylinder "B" Open. On this valve, cylinder "B" is open to the pressure inlet. To open cylinder "A" to pressure, the lever must be moved away from the valve and held in this position. Once released, the spring will return the spool to open cylinder "B".

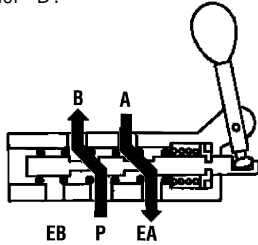

Valve 76429AN2NN00: Three-Position, Spring Centered, All Ports Closed. On this model the spring and retainers are designed so that the spool is centered, all ports are closed, and the hand lever is in the center position. When the lever is moved toward the valve and held, cylinder "B" is open to pressure and cylinder "A" is open to exhaust. When the lever is moved away from the valve and held, cylinder "A" is open to pressure and cylinder "B" is open to exhaust.

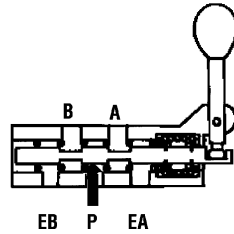

Valve 76469AN2NN00: Two-position No Spring Return. Permits the operator to open cylinder "B" to pressure and cylinder "A" to exhaust when the lever is moved forward, and to reverse the process when the lever is moved in the opposite direction. Since there is no spring, the spool can be left in either position.

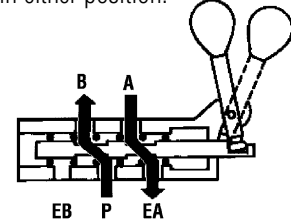

Hand Lever Operated Valves

Pipe Size NPT	Orifice Size (inch)	Cv Factor	Operating Pressure Differential (PSI)		Catalog Number	Const. Ref.
			Minimum	Maximum		
1/4"	1/4	1	0	150	76419AN2NNCB	58
	1/4	1	0	150	76429AN2NN00	58
	1/4	1	0	150	76469AN2NN00	58

DRAWINGS

#58

SKINNER 7000 Series General Purpose Four-Way Pilot Operated Valves

SPECIFICATIONS

Mechanical Characteristics

Standard Materials of Construction

- Body—Brass or 303 Stainless Steel
- Seals—NBR
- Spool—Thermoplastic
- Cages—Thermoplastic
- Sleeve Tube—Stainless Steel (304)
- Plunger—Stainless Steel (430FR)
- Stop—Stainless Steel (430FR)
- Springs—Stainless Steel (18-8 or 17-4)
- Filter—Polyethylene

Compatible Fluids

- Lubricated Air, Non-Lubricated Air, Inert Gases and other gases compatible with materials of construction.

Electrical Characteristics

Voltages

- DC—12, 24
- AC—24/60, 110/50-120/60, 220/50-240/60 (other voltages available upon request)

Agency Approval

- UL approvals are available on valves with applicable coil/enclosure combinations. For additional information see page 122.

Miscellaneous

Minimum Ambient Temperature

- -40°F(-40°C)
Dew point must be more than 7°F below ambient.

Maximum Ambient Temperature

- 10 watt AC/DC—150°F
- 22 watt AC/DC—77°F
- Fluxtron/Magnelatch—122°F

7341, 7347 PILOT OPERATED BRASS OR STAINLESS STEEL VALVES NBR SEALS

Pipe Size NPT	Orifice Size (inch)	Cv Flow Factor	Operating Pressure Differential (PSI)				MAX. Fluid Temp. (F)	Brass Pressure Vessel Catalog Number	Stainless Pressure Vessel Catalog Number	UL/CSA** Approval	Const. Ref.	
			Min.*	Maximum		10 watt						22 watt
				10 watt	22 watt							
Single Solenoid												
1/4"	11/64	0.55	30	150	150	167	73417BN2KN00	73417VN2KN00	GP	135		
	1/4	1.2	30	150	150	167	73417BN2PN00	73417VN2PN00	GP	135		
1/2"	5/8	4.0	30	150	150	167	73417BN4UN00	-	GP	137		
Double Solenoid												
1/4"	11/64	0.55	30	150	150	167	73477BN2KN00	73477VN2KN00	GP	136		
	1/4	1.2	30	150	150	167	73477BN2PN00	73477VN2PN00	GP	136		
1/2"	5/8	4.0	30	150	150	167	73477BN4UN00	-	GP	137		

* Pilot operated valves require the minimum pressure differential specified for proper valve operation.

** GP=General Purpose Valves. See page 122 for additional agency approval information.

7000 Series General Purpose Four-Way Pilot Operated Valves

Four-Way Solenoid Valves

DRAWINGS

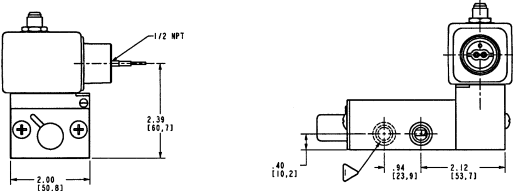
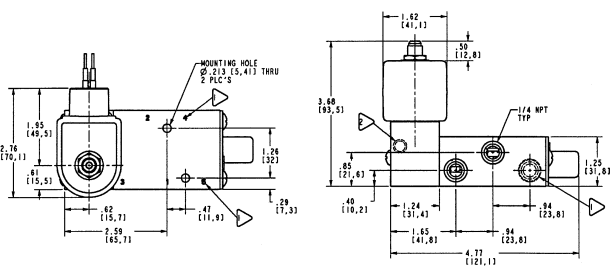

#135

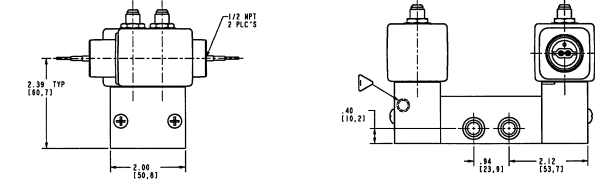
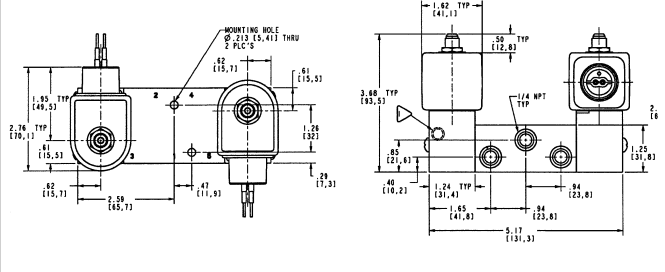
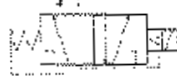

#136

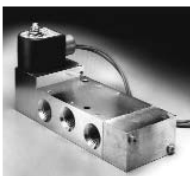
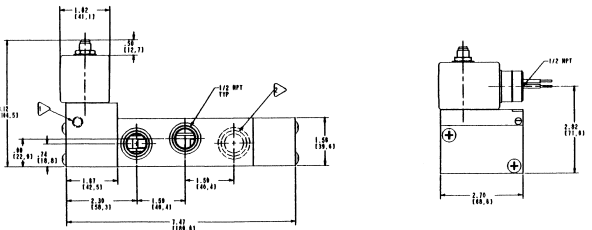
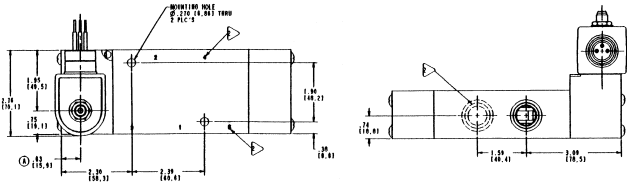
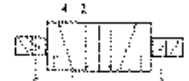

#137



SKINNER V-9 Series Four-Way Direct Acting Valves

SPECIFICATIONS

Mechanical Characteristics

Standard Materials of Construction

- Body—Zinc
- Seals—NBR
- Sleeve—Stainless Steel (304)
- Plunger—Stainless Steel (430FR)
- Shading Ring—Copper (AC & DC only)
- Stop—Stainless Steel (430FR)
- Springs—Stainless Steel (18-8)
- Orifice—Stainless Steel (303)

Compatible Fluids

- Lubricated Air, Non-Lubricated Air, Inert Gases, Hydraulic Fluids, and additional fluids compatible with materials of construction.

Electrical Characteristics

Voltages

- DC—12, 24, 120
- AC—24/60, 120/60, 240/60

Power Consumption

- 10 watts per coil (2 coils)

Coil Class

- Class B, Class H coils available upon request.

Agency Approvals

- UL and CSA approvals are generally available on valves with applicable coil/enclosure combinations. For details, please consult Skinner Valve.

Miscellaneous

Operating Speed

- Up to 600 cycles per minute.

Response Time

- AC—Approximately 4-8 milliseconds to open or close.
- DC—Approximately 10-15 milliseconds to open, 6-12 milliseconds to close.

Ordering V9 Valves:

Example:

- 1) Specify the valve catalog number-V935LB2150
- 2) Specify the required voltage-120V, 60Hz

V933 Four-Way Normally Closed—Normally Closed Valves

When de-energized, both inlet ports are closed by the two plungers preventing flow from the common inlet through both of the valves. The cylinder port in each valve is

open to the common exhaust, permitting flow from the cylinders to the exhaust. When the coils are energized, both valve plungers rise, opening the inlet orifices, and at the

same time closing the orifices in the sleeves. This stops flow from the cylinder ports to the exhaust, and permits flow from the inlet to the cylinder ports.

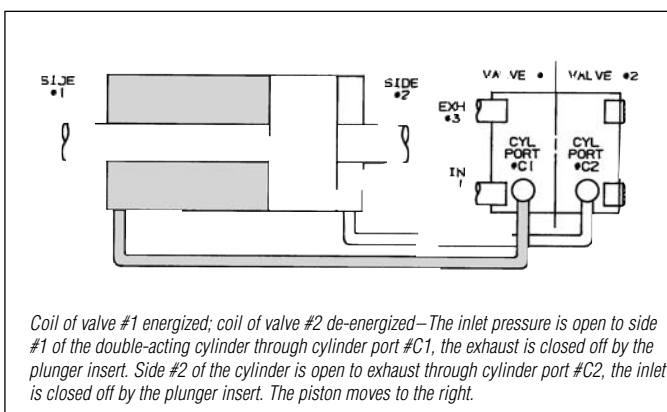
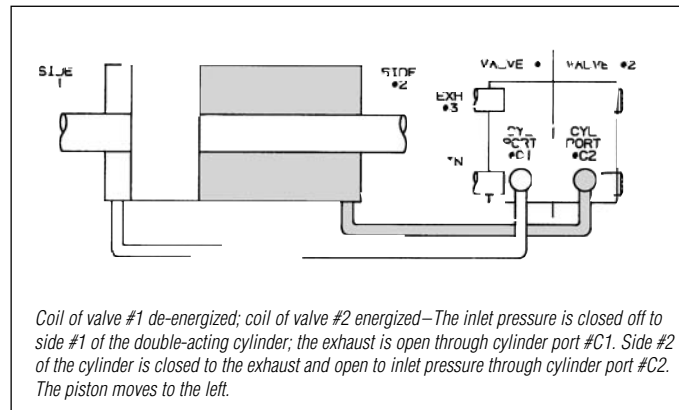
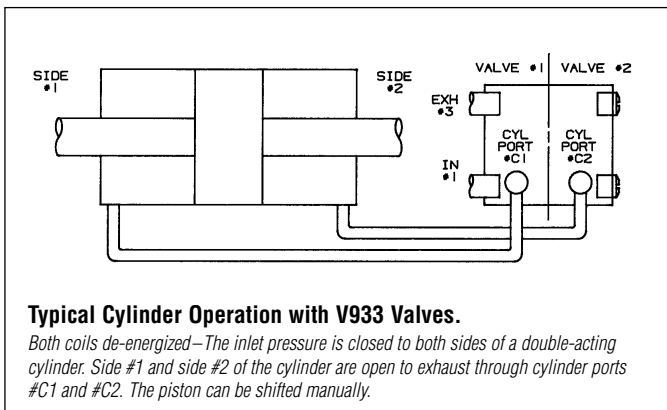

V935 Four-Way Normally Closed-Normally Open Valves

The plungers of the two valves are at opposite positions in both the energized and de-energized conditions—one normally open while the other is normally closed. When de-energized, fluid flows from the inlet of the valve through the inlet port of the normally

open valve, through the sleeve, and out the cylinder port of the valve. At the same time, the normally closed valve inlet orifice is closed, but the orifice in the sleeve is opened, permitting flow from its cylinder port to the common exhaust. Therefore, fluid

flows from the inlet of the valve to the cylinder port of the normally open valve and from the cylinder port of the normally closed valve to the exhaust. When energized, the two valves reverse in position.

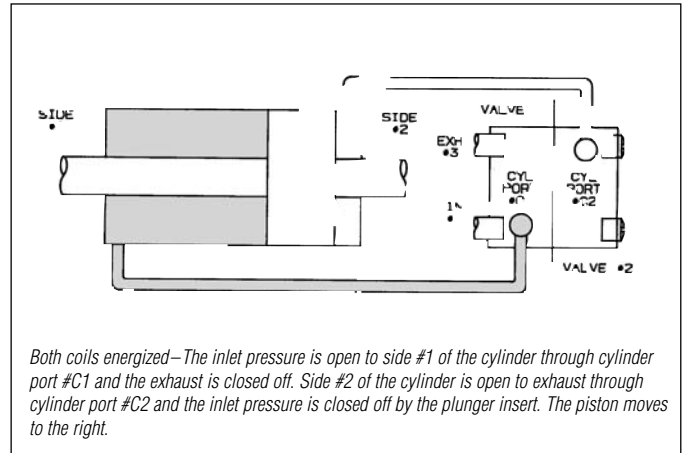
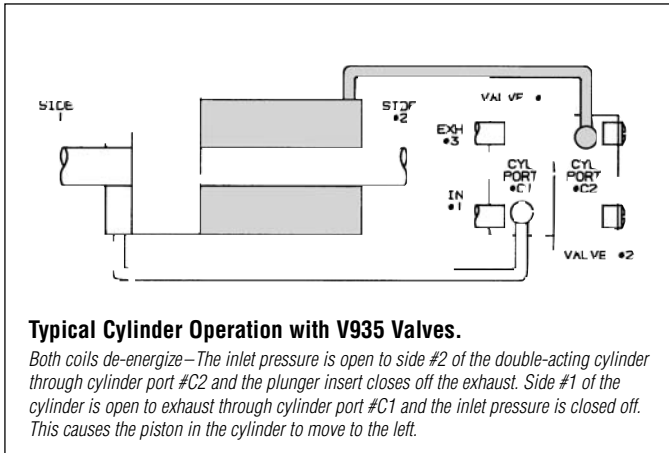

V955 Four-Way Normally Open-Normally Open Valves

Both plungers are in the same position when the coils are de-energized. In this condition, fluid flows through the common inlet of the body, up through the sleeves of both valves, and out the cylinder ports of the valves. Both

orifices in the sleeve stops are closed to the exhaust ports by the plunger. In the energized position, both valve plungers operate together to close the inlet ports, stopping flow into the valve. At the same

time, the orifices in the sleeves are opened, permitting flow from the cylinder ports to the common exhaust port in the body.

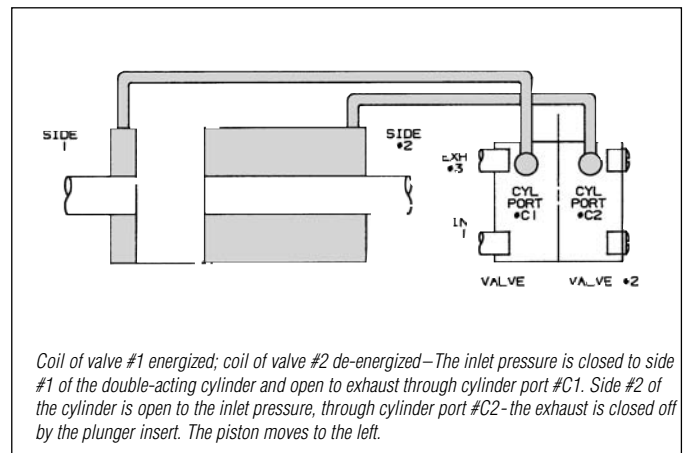
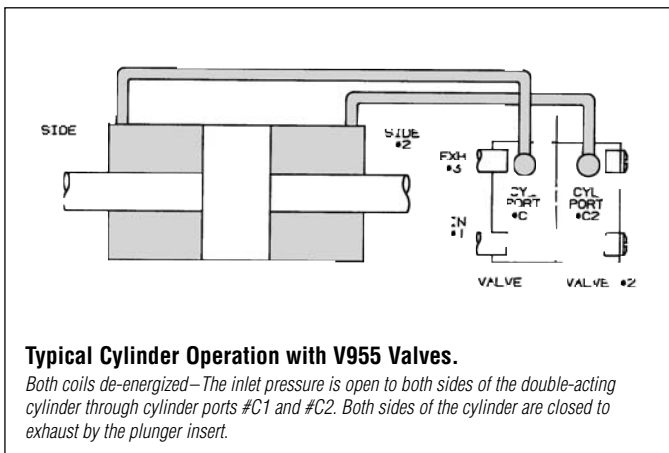

V-9 Series Four-Way Direct Acting Valves

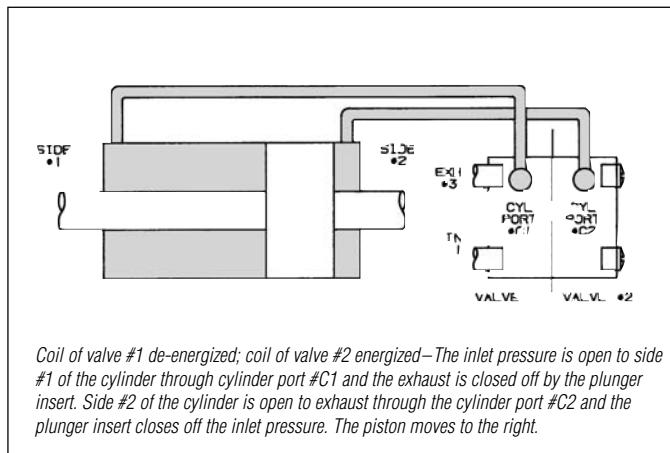

V933 ZINC VALVES—NORMALLY CLOSED-NORMALLY CLOSED NEUTRAL POSITION, NBR SEALS

NPT Pipe Size	Orifice Diameters								*Maximum Operating Pressure Diff. (PSI)	Class B Molded Leaded Coil	Const. Ref.
	Valve #1 (NC)				Valve #2 (NC)						
	Inlet Port	Cv Factor	Exhaust Port	Cv Factor	Inlet Port	Cv Factor	Exhaust Port	Cv Factor			
1/4"	3/64	0.052	1/16	0.095	3/64	0.052	1/16	0.095	150 (200)	V933LB2150	59
	1/16	0.095	3/32	0.14	1/16	0.095	3/32	0.14	100 (125)	V933LB2100	59
	3/32	0.16	3/32	0.14	3/32	0.16	3/32	0.14	75 (90)	V933LB2075	59
	1/8	0.21	3/32	0.14	1/8	0.21	3/32	0.14	50 (65)	V933LB2050	59

V935 ZINC VALVES—NORMALLY CLOSED-NORMALLY OPEN NON-NEUTRAL POSITION, NBR SEALS

NPT Pipe Size	Orifice Diameters								*Maximum Operating Pressure Diff. (PSI)	Class B Molded Leaded Coil	Const. Ref.
	Valve #1 (NC)				Valve #2 (NO)						
	Inlet Port	Cv Factor	Exhaust Port	Cv Factor	Inlet Port	Cv Factor	Exhaust Port	Cv Factor			
1/4"	3/64	0.052	1/16	0.095	3/64	0.052	1/16	0.095	150 (200)	V935LB2150	59
	1/16	0.095	3/32	0.14	1/16	0.08	1/8	0.18	100 (125)	V935LB2100	59
	3/32	0.16	3/32	0.14	3/32	0.14	1/8	0.21	75 (90)	V935LB2075	59
	1/8	0.21	3/32	0.14	3/32	0.14	1/8	0.21	50 (65)	V935LB2050	59

V955 ZINC VALVES—NORMALLY OPEN-NORMALLY OPEN NEUTRAL POSITION, NBR SEALS

NPT Pipe Size	Orifice Diameters								*Maximum Operating Pressure Diff. (PSI)	Class B Molded Leaded Coil	Const. Ref.
	Valve #1 (NO)				Valve #2 (NO)						
	Inlet Port	Cv Factor	Exhaust Port	Cv Factor	Inlet Port	Cv Factor	Exhaust Port	Cv Factor			
1/4"	3/64	0.052	1/16	0.095	3/64	0.052	1/16	0.095	150 (225)	V955LB2150	59
	1/16	0.08	1/8	0.18	1/16	0.08	1/8	0.18	100 (150)	V955LB2100	59
	3/32	0.14	1/8	0.18	3/32	0.14	1/8	0.21	75 (100)	V955LB2075	59

V933 ZINC VALVES—NORMALLY CLOSED-NORMALLY CLOSED NEUTRAL POSITION—WITH ADJUSTABLE FLOW OPTION, NBR SEALS

NPT Pipe Size	Orifice Diameters								*Maximum Operating Pressure Diff. (PSI)	Class B Molded Leaded Coil			Const. Ref.
	Valve #1 (NC)				Valve #2 (NC)					Adjustable Flow At Both Exhausts	Adjustable Flow At Both Inlets	Full Adjustable Flow At Both Exhausts & Inlets	
	Inlet Port	Cv Factor	Exhaust Port	Cv Factor	Inlet Port	Cv Factor	Exhaust Port	Cv Factor					
1/4"	3/64	0.052	1/16	0.095	3/64	0.052	1/16	0.095	150 (200)	V933LEH2150	V933LEP2150	V933LEF2150	59
	1/16	0.105	3/32	0.13	1/16	0.105	3/32	0.13	100 (125)	V933LEH2100	V933LEP2100	V933LEF2100	59
	3/32	0.13	3/32	0.13	3/32	0.13	3/32	0.13	75 (90)	V933LEH2075	V933LEP2075	V933LEF2075	59
	1/8	0.16	3/32	0.13	1/8	0.16	3/32	0.13	50 (65)	V933LEH2050	V933LEP2050	V933LEF2050	59

* Figures in parentheses indicate higher than standard pressure ratings available with slight modifications.

**V935 ZINC VALVES—NORMALLY CLOSED—NORMALLY OPEN
NON-NEUTRAL POSITION—WITH ADJUSTABLE FLOW OPTION, NBR SEALS**

NPT Pipe Size	Orifice Diameters								*Maximum Operating Pressure Diff. (PSI)	Class B Molded Leaded Coil			Const. Ref.
	Valve #1 (NC)				Valve #2 (NO)					Adjustable Flow At Both Exhausts	Adjustable Flow At Both Inlets	Full Adjustable Flow At Both Exhausts & Inlets	
	Inlet Port	Cv Factor	Exhaust Port	Cv Factor	Inlet Port	Cv Factor	Exhaust Port	Cv Factor					
1/4"	3/64	0.052	1/16	0.095	3/64	0.052	1/16	0.095	150 (200)	V935LEH2150	V935LEP2150	V935LEF2150	59
	1/16	0.105	3/32	0.13	1/16	0.08	1/8	0.16	100 (125)	V935LEH2100	V935LEP2100	V935LEF2100	59
	3/32	0.13	3/32	0.13	3/32	0.13	1/8	0.16	75 (90)	V935LEH2075	V935LEP2075	V935LEF2075	59
	1/8	0.16	3/32	0.13	3/32	0.13	1/8	0.16	50 (65)	V935LEH2050	V935LEP2050	V935LEF2050	59

**V955 ZINC VALVES—NORMALLY OPEN-NORMALLY OPEN NEUTRAL
POSITION—WITH ADJUSTABLE FLOW OPTION, NBR SEALS**

NPT Pipe Size	Orifice Diameters								*Maximum Operating Pressure Diff. (PSI)	Class B Molded Leaded Coil			Const. Ref.
	Valve #1 (NO)				Valve #2 (NO)					Adjustable Flow At Both Exhausts	Adjustable Flow At Both Inlets	Full Adjustable Flow At Both Exhausts & Inlets	
	Inlet Port	Cv Factor	Exhaust Port	Cv Factor	Inlet Port	Cv Factor	Exhaust Port	Cv Factor					
1/4"	3/64	0.052	1/16	0.095	3/64	0.052	1/16	0.095	150 (225)	V955LEH2150	V955LEP2150	V955LEF2150	59
	1/16	0.08	1/8	0.16	1/16	0.08	1/8	0.16	100 (150)	V955LEH2100	V955LEP2100	V955LEF2100	59
	3/32	0.13	1/8	0.16	3/32	0.13	1/8	0.16	75 (100)	V955LEH2075	V955LEP2075	V955LEF2075	59

* Figures in parentheses indicate higher than standard pressure ratings available with slight modifications.

For ordering instructions see Ordering Information section on page 10.

DRAWINGS

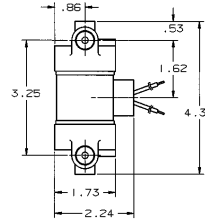

Note: Enclosure and adjustable flow designators (B, EH, EP OR EF) have been omitted for brevity.

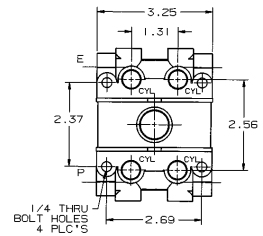

#59

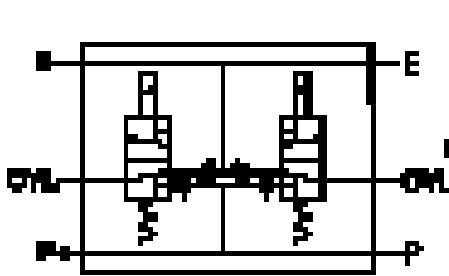

Four-Way Normally Closed-
Normally Closed

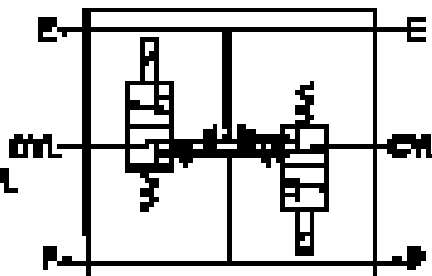

Four-Way Normally Closed-
Normally Open

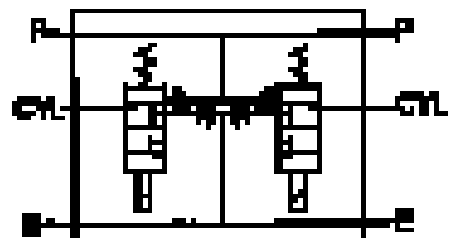

Four-Way Normally Open-
Normally Open

Specialty Valve Contents



Skinner Specialty Valve Specifications	86-90
Skinner 7000 Series Valves	86
Hydraulic Two-Way Valves	86
Dry Operator Valves	87-89
Hydraulic Three-Way Valves	90
Skinner Dual-Flow Valves	91
Skinner BP Proportional Valves	92-93
Skinner Intrinsically Safe Valves	94-107
Intrinsically Safe Two-Way Valves	95-96
Intrinsically Safe Three-Way Valves	97-98
Intrinsically Safe Special Purpose Valves	99
Intrinsically Safe Four-Way Valves	100-101
Coil and Enclosure Information	102-107
Skinner A-10 Series Valves	108-109
Skinner MB Series Valves	110-111
Electropneumatic Pressure Regulator (EPP3)	112-113

SKINNER 7000 Series Hydraulic Two-Way Direct Acting Valves

SPECIFICATIONS

Product Description

Skinner Hydraulic valves are specifically designed for use in hydraulic systems. The valves are spool type valves that can withstand a static pressure up to 1000 PSI. All internal parts are compatible with most hydraulic fluids.

Mechanical Characteristics

Standard Materials of Construction

- Body—Stainless Steel (430F)
- Seals—Metal (spool type)
- Sleeve Tube—Stainless Steel (304)
- Armature—Stainless Steel (430FR)
- Stop—Stainless Steel (430FR)
- Springs—Stainless Steel (18-8)
- Shading Rings—Copper
- Spool—Stainless Steel (17-4PH)
- Flange Seal—NBR

Compatible Fluids

- Hydraulic Fluids.

Electrical Characteristics

Voltages

- DC—12, 24
- AC—24/60, 110/50-120/60, 220/50-240/60, (other AC/DC voltages available upon request)

Power Consumption

- 10 watts

Agency Approvals

- UL and CSA approvals are available on valves with applicable coil/enclosure combinations. For additional information see page 122.

Valve Construction Alternatives

Mounting

- Manifold, flange and cage types available. Consult factory for details.

Miscellaneous

Maximum Ambient Temperature

- 10 watt AC/DC—150°F
- Fluxtron/Magnelatch—122°F

Leakage

- Internal—At 70°F with MIL-H-5606 oil, maximum allowable leakage is 80cc/min. at 1000 PSI.
- External—None

DIRECT ACTING STAINLESS STEEL VALVES—NORMALLY CLOSED

Pipe Size NPT	Orifice Size (inch)	Cv Factor	Static Pressure (PSI)		MAX. Fluid Temp. (F)	Pressure Vessel Number	UL/CSA* Approval	Const. Ref.	
			Maximum						
			Min.	AC Rating 10 watt					DC Rating 10 watt
1/8"	7/64	0.21	0	1000	1000	185	71211SN1MM00	GP	60

DIRECT ACTING STAINLESS STEEL VALVES—NORMALLY OPEN

Pipe Size NPT	Orifice Size (inch)	Cv Factor	Static Pressure (PSI)		MAX. Fluid Temp. (F)	Pressure Vessel Number	UL/CSA* Approval	Const. Ref.	
			Maximum						
			Min.	AC Rating 10 watt					DC Rating 10 watt
1/8"	7/64	0.21	0	1000	1000	185	71221SN1MM00	GP	60

* UL/CSA Approval Information: SS=safety Shutoff GP=General Purpose Blank=Not Approved See page 136 for additional agency approval information.

For mechanical option S2, silver shading ring and Teflon flange seal, substitute S2 for 00 in the part number.

DRAWINGS

#60

Port Identification:	
71211	71221
1-IN	1-Plug
2-OUT	2-OUT
3-Plug	3-IN

SKINNER 7000 Series Dry Operator Two-Way Direct Acting Valves

SPECIFICATIONS

Product Description

The 7000 Series Dry Operator valve line is specially designed for non-contaminating and corrosive applications. The valves assure absolute purity and inertness to corrosion when used with a broad range of fluids.

Dry Operator valves feature two basic construction innovations. The operator is physically isolated from the fluid by a diaphragm so only the seal and valve body come in contact with the fluid. And, valve bodies of Noryl and Teflon provide the purity from contamination and resistance to corrosion many industries demand.

Mechanical Characteristics

Standard Materials of Construction

- Body—Noryl, Teflon, Stainless Steel (303)
- Seals—PTFE and FKM as listed.

- Sleeve Tube—Stainless Steel (304)
- Plunger—Stainless Steel (430FR)
- Stop—Stainless Steel (430FR)
- Springs—Stainless Steel (18-8)
- Shading Ring—Copper

Compatible Fluids

- Fluids compatible with diaphragm and body materials. See Fluid Compatibility Chart.

Electrical Characteristics

Voltages

- DC—12, 24
- AC—24/60, 110/50-120/60, 220/50-240/60, (consult factory for other voltages)

Power Consumption

- 10, 22 watts

Agency Approvals

- UL and CSA approvals are available on valves with applicable coil/enclosure combinations. For additional information see page 122.

Miscellaneous

Maximum Ambient Temperature

- 10 watt AC/DC—150°F
- 22 watt AC/DC—77°F

Important Application Information On Back Pressure Data

Dry operator valves require consideration of back pressure since the back pressure acts on a large area of the diaphragm. Excessive back pressure can keep the valves open on de-energization. The back pressure a standard valve can operate against depends on the orifice size, pressure differential and whether the media is a gas or liquid.

The following two charts provide a method to verify that the valve selected can meet the application back pressure requirements.

For applications involving back pressure that cannot be handled by catalog valves, please consult Skinner Valve.

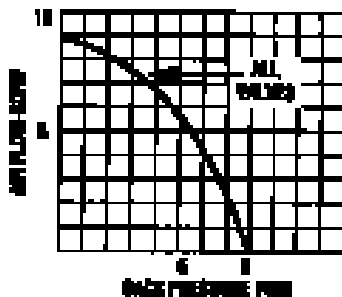
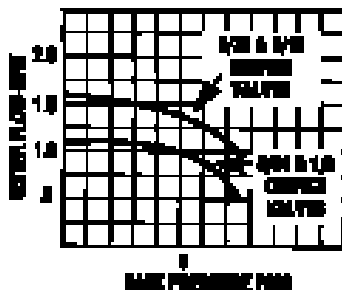

Helpful Application Suggestions:

To keep the back pressure to a minimum, the downstream line should be as short as possible and be of the largest practical size. All restricting or flow controlling elements should be installed upstream.

Use of Back Pressure Charts:

To use the charts, it is necessary to know the flow and back pressure.

1) First calculate the flow in GPM for liquids or SCFM for gases from the flow charts in the Technical Information Section.

2) The back pressure is the downstream pressure in the system. A catalog valve may be used if the intersection of flow and back pressure is below the curve for its orifice size.

7000 Series Dry Operator Two-Way Direct Acting Valves

DIRECT ACTING NORYL VALVES—NORMALLY CLOSED, 3/8" BARB, FKM SEALS

Pipe Size NPT	Orifice Size (inch)	Cv Factor	Operating Pressure Differential (PSI)				MAX. Fluid Temp. (F)	Pressure Vessel Number	UL/CSA* Approval	Const. Ref.	
			Min.	Maximum		Min.					Max.
				AC Ratings	DC Ratings						
			10 watt	22 watt	10 watt	22 watt					
3/8" BARB	5/32	0.35	0	35		35	140	71214LT3QV00	GP	62	
	3/16	0.47	0	20		20	140	71214LT3SV00	GP	62	

DIRECT ACTING TEFLON VALVES—NORMALLY CLOSED, 1/4" NPT, PTFE SEALS

Pipe Size NPT	Orifice Size (inch)	Cv Factor	Operating Pressure Differential (PSI)				MAX. Fluid Temp. (F)	Pressure Vessel Number	UL/CSA* Approval	Const. Ref.	
			Min.	Maximum		Min.					Max.
				AC Ratings	DC Ratings						
			10 watt	22 watt	10 watt	22 watt					
1/4" NPT	5/64	0.16	0	70		70	140	71214TN2KT00	GP	63	
	3/16	0.47	0	20		20	140	71214TN2SV00	GP	63	
	3/16	0.47	0	20		20	140	71214TN2ST00	GP	63	

DIRECT ACTING STAINLESS STEEL VALVES—NORMALLY CLOSED, 1/4" NPT, PTFE SEALS

Pipe Size NPT	Orifice Size (inch)	Cv Factor	Operating Pressure Differential (PSI)				MAX. Fluid Temp. (F)	Pressure Vessel Number	UL/CSA* Approval	Const. Ref.	
			Min.	Maximum		Min.					Max.
				AC Ratings	DC Ratings						
			10 watt	22 watt	10 watt	22 watt					
1/4" NPT	3/16	0.47	0	20		20	140	71214VN2ST00	GP	4	

* UL/CSA Approval Information: SS=Safety Shutoff GP=General Purpose Blank=Not Approved

See page 122 for additional agency approval information.

7000 Series Dry Operator Two-Way
Direct Acting Valves

DRAWINGS

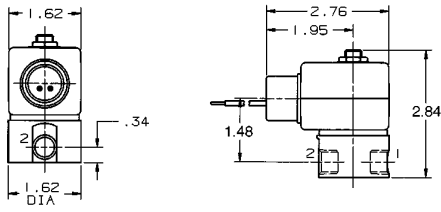

#4

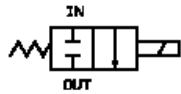
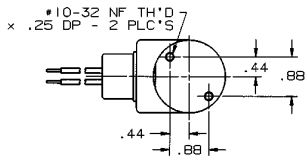

Port Identification: 1-OUT/ 2-IN

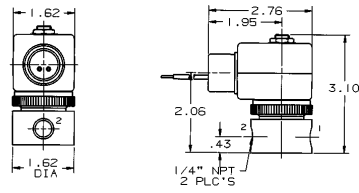

#63

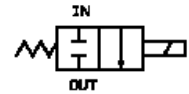
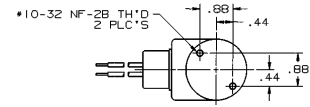

Port Identification:
1-OUT/ 2-IN

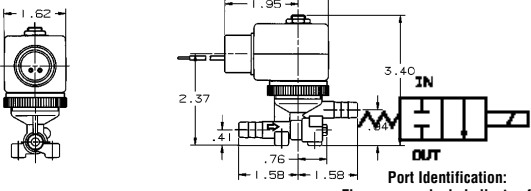

#62

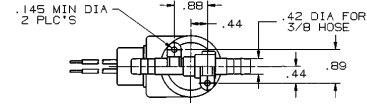

Port Identification:
Flow area on body indicates flow
direction—ports are not marked.

SKINNER Hydraulic 7000 Series Three-Way Direct Acting Valves

SPECIFICATIONS

Product Description

Specifically designed for use in hydraulic systems, these valves are spool type valves that can withstand a static pressure up to 1000 PSI. All internal parts are compatible with most hydraulic fluids. A range of custom mounting types are available including manifold, flange and cage designs.

Mechanical Characteristics

Standard Materials of Construction

- Body—Stainless Steel (430F)
- Seals—Metal
- Flange Seal—NBR
- Sleeve Tube—Stainless Steel (304)
- Plunger—Stainless Steel (430FR)
- Stop—Stainless Steel (430FR)
- Springs—Stainless Steel (18-8)
- Shading Ring—Copper
- Spool—Stainless Steel (17-4PH)

Compatible Fluids

- Hydraulic Fluids.

Electrical Characteristics

Voltages

- DC—12, 24
- AC—24/60, 110/50-120/60, 220/50-240/60, (other AC/DC voltages available upon request)

Power Consumption

- 10

Agency Approvals

- UL and CSA approvals are available on valves with applicable coil/enclosure combinations. For additional information see page 122.

Miscellaneous

Leakage

- Internal—At 70°F with MIL-H-5606 oil, maximum allowable leakage is 80cc/min. at 1000PSI.
- External—None.

Maximum Ambient Temperature

- 10 watt AC/DC—150°F
- 22 watt AC/DC—77°F
- Fluxtron/ Magnelatch—122°F

Valve Construction Alternatives

Mounting

- Manifold, flange and cage types available. Consult factory for details.

3 WAY MULTIPURPOSE HYDRAULIC VALVES

Pipe Size NPT	Orifice Body NC (inch)	Orifice Body NO (inch)	Cv Factor NC	Cv Factor NO	Min.	Static Pressure (PSI)				Max. Fluid Temp. (F)	Pressure Vessel Catalog Number	UL/CSA* Approval	Const. Ref.
						Maximum							
						AC Ratings		DC Ratings					
						10 watt	22 watt	10 watt	22 watt				
1/8"	7/64	7/64	0.21	0.21	0	1000	2200	1000	2200	185	71331SN1MM00	GP	91

* UL/CSA Approval Information: GP=General Purpose Blank=Not Approved

See page 122 for additional agency approval information.

MAXIMUM PERMISSIBLE FLOW AND PRESSURE DIFFERENTIALS

Valve Function	Flow Path	Maximum Flow (GPM)	Maximum Pressure Differential (PSI)
Normally Closed	1 to 2	5.70	700
	2 to 3	5.70	700
Normally Open	3 to 2	6.50	900
	2 to 1	3.50	450
Diverting	2 to 3	2.50	150
	2 to 1	2.50	150

For mechanical option S2, silver shading ring and Teflon flange seal, substitute S2 for 00 in the part number.

DRAWINGS

Technical drawings showing dimensions and port configurations for the valve. Dimensions include 1.62, 2.76, 1.95, 3.52, 2.50, 1.22, .47, .80, .63, and 1.25. Port configurations are labeled: NORMALLY CLOSED, NORMALLY OPEN, MULTIPURPOSE, and DIVERTING. A note specifies: #10-32 NF TH'D x .25 DP - 2 PLC'S.

#91

Port Identification:				
	NC	NO	71331	Diverting
1	Pressure	Exhaust	NC	NC
2	Cylinder	Cylinder	Cylinder	IN
3	Exhaust	Pressure	NO	NO

SKINNER Dual-Flow Series Dispensing Two-Way Diaphragm Valves

SPECIFICATIONS

Product Description

Skinner Dual-Flow solenoid valves are designed to control two flow rates on command. The valves are actually two valves in one compact assembly using a single dual-wound coil. The valves accurately dispense a predetermined amount of liquid by providing a high-flow (full-flow) for delivery of the bulk amount, and then switch to the low-flow mode to dispense the final amount required.

Skinner Dual-Flow valves can be ordered with a variety of optional features to best adapt to specific installation requirements.

Mechanical Characteristics

Flow Sequence

- Off-Low-High-Low-Off

Standard Materials of Construction

- Body—Brass
- Seals—Fluorocarbon (FKM)

- Diaphragm—NBR
- Sleeve—Stainless Steel
- Plunger—Stainless Steel
- Springs—Stainless Steel
- Shading Ring—Copper

Maximum Ambient and Fluid Temperature

- 104°F (40°C)

Electrical Characteristics

Voltages

- DC—Consult Factory
- AC—120/60-110/50, 240/60-220/50, (other AC/DC voltages available upon request)

Power Consumption

- High—15 watts
- Low Flow—8 watts

Agency Approvals

- UL listed and CSA Certified (CENELEC available upon request)

Coil

- Class F taped with 3 gasoline vapor resistant lead wires.

Miscellaneous

Applications

- Fuel Dispensing
- Process Industries (Blending/Mixing/Batching)
 - Petrochemical
 - Refining
 - Food
 - Pharmaceutical

XLG2 TYPE DUAL FLOW BRASS VALVES—NORMALLY CLOSED

Pipe Size Body NPT	Orifice Diameter		Cv Factor		Operating Pressure Differential (PSI)		1/2" NPT Conduit Explosion Proof	Const. Ref.
	Full Flow	Low Flow	Full Flow	Low Flow	Min.	Maximum AC		
3/4"	3/4	3/32	5.5	0.17	5	50	XLG20600	64
1"	1	1/16	13	0.12	5	50	XLG201030	64
1 1/2"	1 1/4	1/16	21	0.12	5	50	XLG201530	65

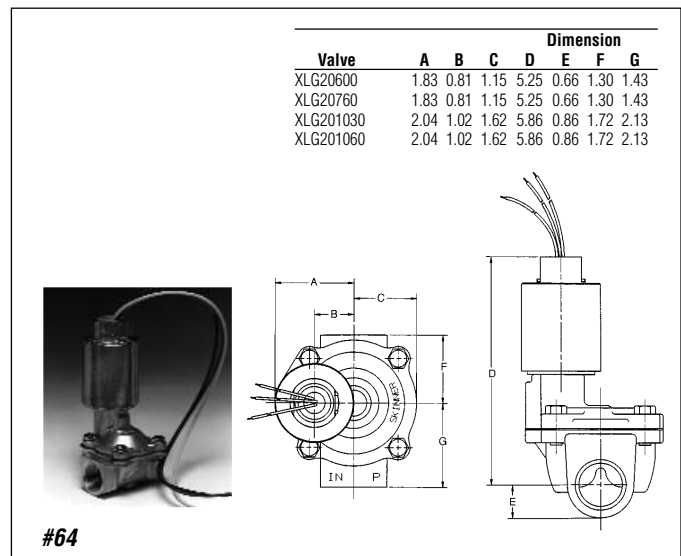
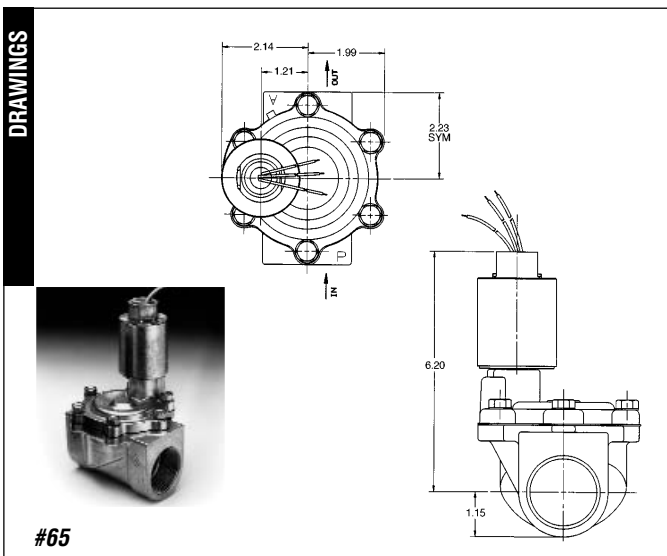

SKINNER BP Proportional Series Two-Way Valves

SPECIFICATIONS

Mechanical Characteristics

Standard Materials of Construction

- Body—Stainless Steel
- Seals—NBR, Fluorocarbon (FKM)
- Sleeve Tube—Stainless Steel
- Plunger—Stainless Steel
- Stop—Stainless Steel
- Springs—Stainless Steel
- Orifice—Stainless Steel

Compatible Media

- All gases compatible with valve materials.
For more detail consult the Fluid Compatibility Chart on page 116.

Electrical Characteristics

Voltages

- 12-24 VDC compatibility

Power Consumption

- 7 watts maximum

Miscellaneous

Temperature

- Ambient—14°F to 122°F (-10°C to 50°C)
- Media—0°F to 180°F (-18°C to 82°C)

Hysteresis

- 10% of full flow (in open loop applications)

Repeatability of a Valve

- 5% when operating within Linear Control Range

Response Time

For complete cycle, Off-Full Open-Off

- 40 msec at zero pressure
- 100 msec at max. pressure

Coil Type

- Class A

Enclosure

- General Purpose, NEMA 1

Operating Principle

The Skinner BP valve is an analog proportional device. The current supplied to the coil of the BP valve is digitally modulated by the electronic package. The mechanism which opens and closes the valve's flow orifice moves in a linear manner in response to the varying coil current. The amount that the orifice is opened is a function of the user's input signal to the valve.

Traditional proportional control solenoid valves are operated by pulse width modulation which entails proportionally controlling flow by modulating the "open time" in a fully closed-fully open-fully closed cycle. The BP does not operate in this manner.

Benefits of analog control technology used in the BP valve include longer valve life, linear flow control, no pressure or flow spikes, faster response time, simplified control systems and less power consumption.

Control Systems

Proportional solenoid valves, whether analog controlled or pulse width modulated, can be used in open or closed-loop control systems. In open-loop control, the input signal to the valve is not coupled to feedback from the system. In closed-loop control, sensors provide system information (pressure, flow, temperature) to the controller, which then adjusts the input signal to the valve until the desired condition is reached.

BP Valves in Open-Loop Systems

Non-critical applications can be controlled in an open-loop fashion. Under steady state conditions an input signal to the valve will open the orifice and produce a certain amount of flow. However, when system conditions change, such as pressure, the output of the valve will also change.

BP Valves in Closed-Loop Systems

For applications requiring more precise control, closed-loop control systems are recommended. In such systems, measurements of process parameters (provided by pressure, temperature and/or flow sensors) are compared to a desired set-point by a controller. If a discrepancy exists, the controller will change the input signal to the BP valve until the desired setpoint is achieved.

BP Proportional Series Two-Way Valves

BP VALVES—NORMALLY CLOSED

Pipe Size (NPT)	Orifice Size (inches)	Cv	Maximum Operating Pressure (PSI)	Flow Ranges		Catalog Number				Const. Ref.
				At Maximum Operating Pressure (SCCM)	10 PSI Example (SCCM)	Control Input Signal				
						0-2V	0-5V	0-10V	4-20mA	
1/8"	1/32	0.02	200	0-50,000	0-8,000	BP2EV0001	BP2EV0012	BP2EV0013	BP2EV0029	66
1/8"	3/64	0.045	100	0-65,000	0-17,000	BP2EV0002	BP2EV0010	BP2EV0011	BP2EV0024	66
1/8"	1/16	0.08	60	0-75,000	0-30,000	BP2EV0003	BP2EV0005	BP2EV0009	BP2EV0020	66
1/8"	5/64	0.12	40	0-80,000	0-45,000	BP2EV0004	BP2EV0006	BP2EV0008	BP2EV0014	66

Note: Custom configurations and calibrations are available to suit your exact flow requirements. For information consult the factory.

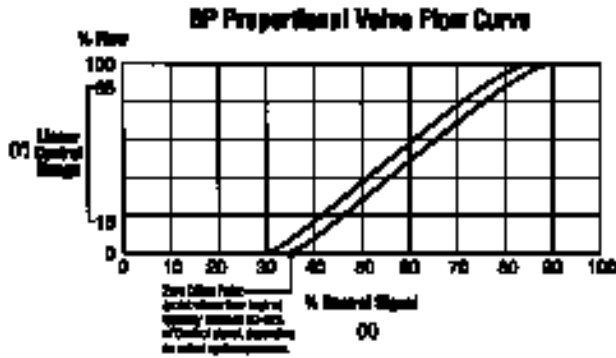

DRAWINGS

Technical drawings of a BP valve. The top view shows a circular body with a diameter of 1.204 inches and a mounting hole diameter of 1.204 inches. The side view shows a length of 1.500 inches and a mounting hole diameter of 1.204 inches. The cross-sectional view shows a diameter of 1.204 inches and a mounting hole diameter of 1.204 inches. Labels include 'RED PORTING', 'BLACK CONTROL', and 'SOLY CONTROL'. Dimensions are provided in inches.

#66

SKINNER Intrinsically Safe Series

SKINNER INTRINSICALLY SAFE SOLENOID VALVES

For hazardous and low-power applications

Today, intrinsically safe systems and products are recommended, or in some cases compulsory, where the highest level of protection from explosion is required. They are also employed in applications that require low power.

A hazardous (classified) location is where fire or explosion hazards exist due to the presence of flammable gases or vapors, flammable liquids, combustible dust, or easily ignitable fibers or flyings.

Skinner Valve has long served industry with innovative and safety related products. Our Intrinsically Safe solenoid valves have approvals for use in the United States and Canada in hazardous classifications for Classes I, II, III, Division 1 and 2, and in the United Kingdom for Division 0, 1 and 2. In Europe our valves are approved according to CENELEC standards. All countries in Western Europe now follow common (CENELEC) standards. All CENELEC member countries should recognize apparatus which have been tested and certified by any CENELEC member country.

What is an intrinsically safe system?

An intrinsically safe system is most often an assembly of approved intrinsically safe apparatus, associated apparatus, and interconnecting cables. Approved I.S. apparatus are devices that are incapable, during normal operation or under fault conditions, of causing explosive atmospheres to ignite by spark or thermal effect. Explosive atmospheres are mixtures of flammable or combustible material in air in their most easily ignitable concentrations.

Solenoid valves are examples of I.S. apparatus and must be approved for use in specific hazardous (classified) locations. Associated apparatus, such as safety barriers, are devices which are not necessarily intrinsically safe themselves, but which are not necessarily intrinsically safe themselves, but which affect the energy in the I.S. circuit and are relied upon to maintain intrinsic safety.

How does intrinsic safety apply to solenoid valves?

When related to solenoid valves, intrinsic safety means that the coil's current draw and resulting temperature is held to such a low level (by an approved safety barrier) that the valve no longer has the capability of igniting a mixture of flammable or combustible material, either during normal operation or under fault conditions.

When designed into an intrinsically safe system, Skinner's Intrinsically Safe solenoid valves provide a number of significant performance advantages.

Low Power Consumption

Skinner's Intrinsically Safe valves are rated at 24 VDC nominal, and are calibrated to operate at a minimum current draw as low as 29 milliamps (0.029 amps).

Low Temperature Rise

Skinner Intrinsically Safe valve enclosures are designed to maintain a maximum outside surface temperature less than 85°C. This meets the T6 classification assigned by Underwriters Laboratories Inc.

Variety of Mounting Possibilities

Skinner Intrinsically Safe valves can be mounted in any position and still operate normally.

Media Compatibility

Intrinsically Safe Skinner valves in 2-way constructions are suitable for use with oil, air, water, and inert gases. Our 3- and 4-way valves are suitable for use with air and inert gases only.

Wide Selection of Options

A selection of coil enclosures including splice box, cable, 1/2" NPT conduit, and DIN coils are available for use with Skinner Intrinsically Safe valves. Additionally, some models are offered in manifold mounted configurations.

Watertight Construction

All Intrinsically Safe Skinner coil enclosures are equivalent to NEMA 4 Watertight construction.

SKINNER Intrinsically Safe Series Two-Way Direct Acting and Pilot Operated Valves

SPECIFICATIONS

Mechanical Characteristics

Standard Materials of Construction

- Body—Brass
- Seals—FKM, NBR.

Compatible Media

- Air, water and light oil.

Electrical Characteristics

Based on coil selected. See catalog pages 102-106 for detailed electrical information.

Miscellaneous

For applications below freezing temperatures, valves must be degreased. Consult Skinner prior to ordering.

INTRINSICALLY SAFE SOLENOID VALVES—TWO-POSITION

Part Number	Valve Type	Port Size NPTF	Orifice Size	Valve Materials Seal/Body	Operating Pressure Differential (PSI)	Flow Rate Cv/SCFM*	Minimum Ambient Temp. °F/°C	Maximum Fluid Temp. °F/°C	Valve Weight lbs.	Const. Ref.
U121K0490	2W,NC	1/4"	3/64"	FKM/Brass	0-150	0.04/1.2	+14/-10	165/75	0.44	72
U121K0890	2W,NC	1/4"	1.2mm	FKM/Brass	0-100	0.06/1.75	+14/-10	165/75	0.44	72
U121K0690	2W,NC	1/4"	1.5mm	FKM/Brass	0-75	0.11/2.8	+14/-10	165/75	0.44	72
U321H1590	2W,NC	1/2"	5/8"	FKM, NBR/Brass	5-150	4.4/110	+14/-10	165/75	1.38	73
U321G3690	2W,NC	3/4"	3/4"	FKM, NBR/Brass	5-150	9.8/330	+14/-10	165/75	2.86	74
U321G3790	2W,NC	1"	1"	FKM, NBR/Brass	5-150	12.6/490	+14/-10	165/75	2.42	74
U321G3890	2W,NC	1 1/4"	1 1/4"	FKM, NBR/Brass	5-150	19.6/630	+14/-10	165/75	3.75	74
U321G3990	2W,NC	1 1/2"	1 9/16"	FKM, NBR/Brass	5-150	29.5/1100	+14/-10	165/75	5.30	74
U321G4090	2W,NC	2"	1 9/16"	FKM, NBR/Brass	5-150	39.2/1400	+14/-10	165/75	6.17	74

* Measured at 90 PSI with a 15 PSI differential.

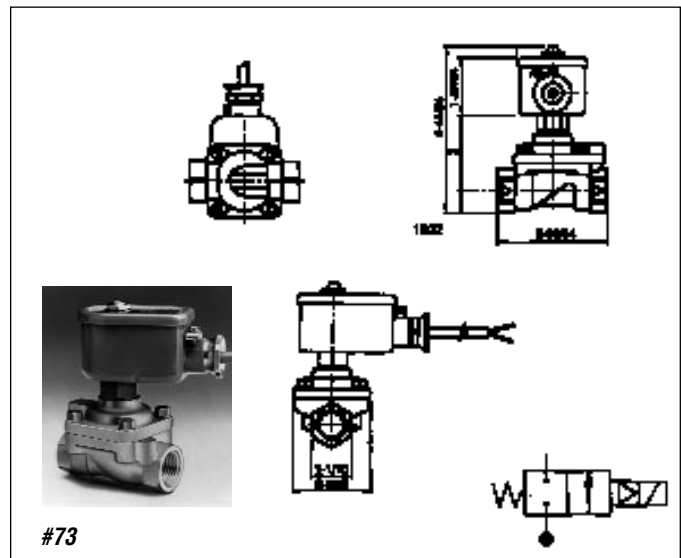
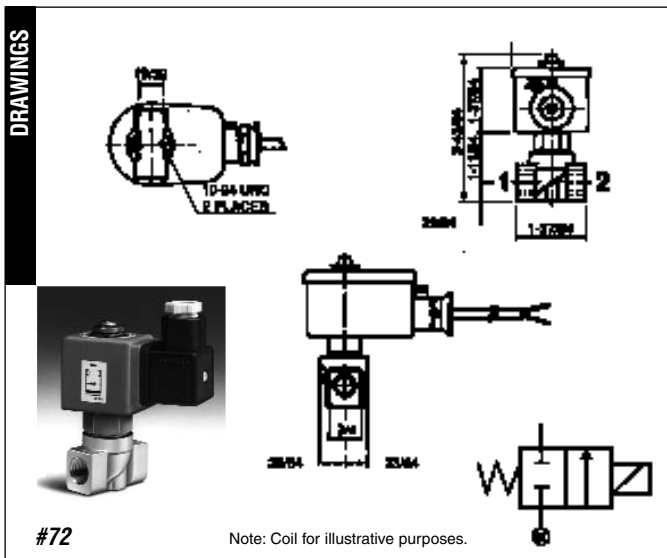

Intrinsically Safe Series Two-Way Direct Acting and Pilot Operated Valves

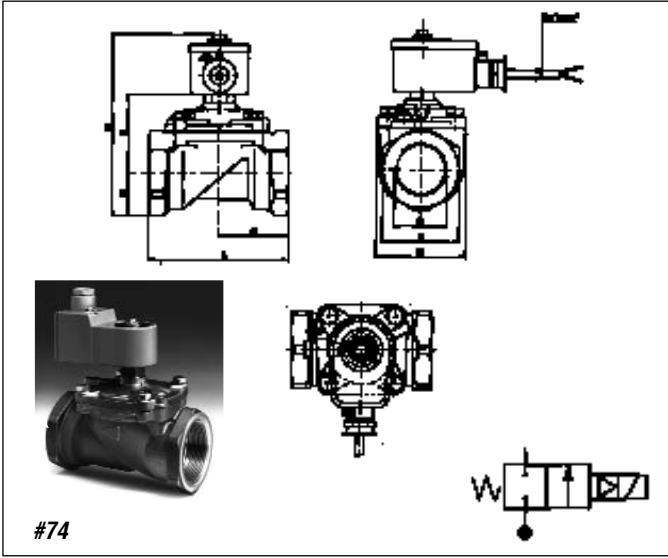

Valve	A		B		C		D		E		F		G	H	
	IN	MM	IN	MM	IN	MM	IN	MM	IN	MM	IN	MM	NPT	IN	MM
U321G3690	3-15/16"	100	5-5/16"	135	2"	50	7/8"	23	2-23/64"	60	1-5/8"	41	3/4"	2-3/4"	70
U321G3790	3-15/16"	100	5-5/16"	135	2"	50	7/8"	23	2-23/64"	60	1-5/8"	41	1"	2-3/4"	70
U321G3890	4-11/32"	110	6-7/32"	158	2-5/32"	55	1-9/32"	33	2-7/8"	73	2-3/8"	60	1-1/4"	2-3/4"	70
U321G3990	5-17/32"	140	6-7/32"	158	3"	75	1-9/32"	33	2-7/8"	73	2-3/8"	60	1-1/2"	3-1/16"	99
U321G4090	5-29/32"	150	6-25/32"	172.5	3-5/32"	80	1-21/32"	41.5	3-7/64"	79	3"	75	2"	3-1/16"	99

SKINNER Intrinsicly Safe Series Three-Way Direct Acting and Pilot Operated Valves

SPECIFICATIONS

Mechanical Characteristics

Standard Materials of Construction

- Body—Brass, Stainless Steel or Aluminum
- Seals—FKM, NBR.

Compatible Fluids

- Air and inert gases.

Electrical Characteristics

- Based on coil selected. Valve U133X5196 functions with coil part numbers 490860, 482660, and 48333.01 only. See catalog pages 102-106 for detailed electrical information.

Miscellaneous

Sleeve Exhaust Adaptor

- U21-004 must be ordered separately.

For applications below 32°F, valves must be degreased. Consult Fluid Control Division prior to ordering.

INTRINSICALLY SAFE SOLENOID VALVES—TWO-POSITION

Part Number	Valve Type	Port Size NPTF	Orifice Size	Valve Materials Seal/Body	Operating Pressure Differential (PSI)	Flow Rate Cv/SCFM*	Minimum Ambient Temp. °F/°C	Maximum Fluid Temp. °F/°C	Valve Weight lbs.	Const. Ref.
U131K0490	3W, NC	1/4"	3/64"	FKM/Brass	0-150	0.04/1.25	+14/-10	165/75	0.44	75
U131K0890	3W, NC	1/4"	1.2mm	FKM/Brass	0-100	0.06/1.75	+14/-10	165/75	0.44	75
U131K0690	3W, NC	1/4"	1.5mm	FKM/Brass	0-75	0.11/2.8	+14/-10	165/75	0.40	75
U131V5490	3W, NC	1/4"	3/64"	FKM/S.Steel(303)	0-150	0.04/1.25	+14/-10	165/75	0.50	76
U131V5890	3W, NC	1/4"	1.2mm	FKM/S.Steel(303)	0-100	0.06/1.75	+14/-10	165/75	0.53	76
U131V5690	3W, NC	1/4"	1.5mm	FKM/S.Steel(303)	0-75	0.11/2.8	+14/-10	165/75	0.53	76
U133X5196	3W,U	1/4"	5mm	NBR/S.Steel (316)	0-150	.63/24.5	+14/-10	165/75	1.81	77
U131F4490	3W, NC	Subbase	3/64"	FKM/Brass	0-150	0.04/1.25	+14/-10	165/75	0.30	78
U131F4890	3W, NC	Subbase	1.2mm	FKM/Brass	0-100	0.06/1.75	+14/-10	165/75	0.33	78
U131F4690	3W, NC	Subbase	1.5mm	FKM/Brass	0-75	0.11/2.8	+14/-10	165/75	0.33	78
U331B7490	3W, NC	1/4"	9/32"	FKM, NBR/Aluminum	15-150	0.70/26	+14/-10	165/75	0.88	79
U331L2190	3W, NC	1/2"	5/8"	FKM, NBR/Aluminum	7-150	4/175	+14/-10	165/75	2.90	80

* Measured at 90 PSI with a 15 PSI differential.

Note: U133X5196 valves function with coils 490860, 482660 or 483330.01 only.

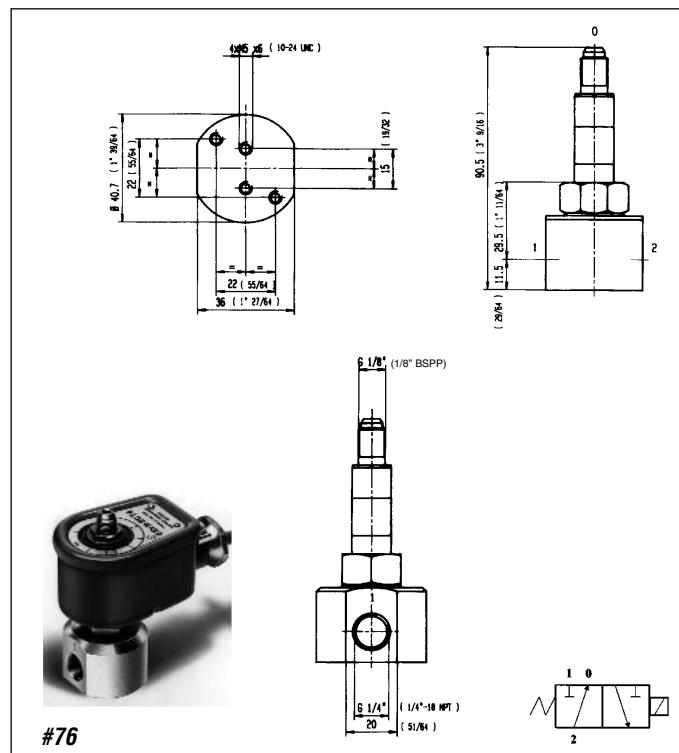
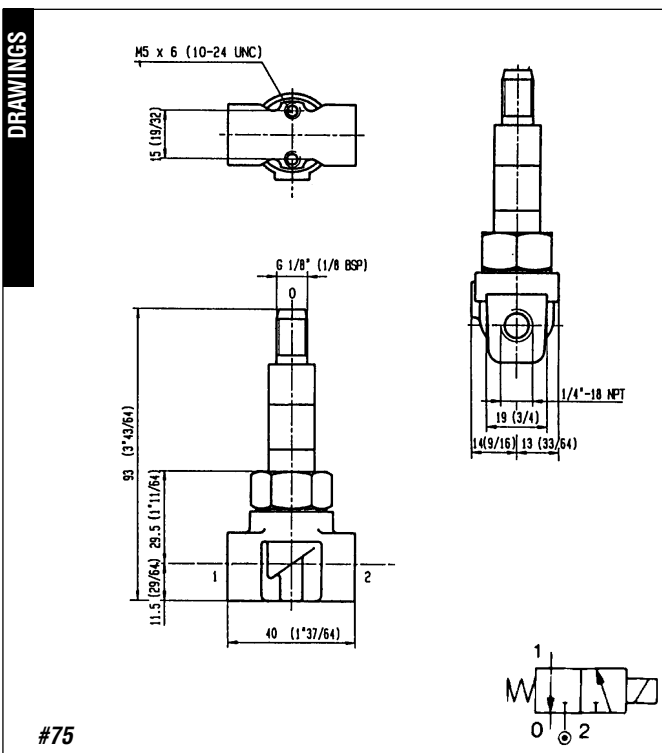

SKINNER Intrinsicly Safe Series Special Purpose Three-Way Quick Exhaust and Manual Reset Valves

SPECIFICATIONS

Mechanical Characteristics

Standard Materials of Construction

- Body—Brass, Stainless Steel
- Seals—NBR, FKM

Compatible Fluids

- Air and inert gases.

Electrical Characteristics

- Based on coil selected, the Quick Exhaust valve functions with coil numbers 490860, 482660 and 483330.01 only. See catalog page 106 for detailed electrical information.

Miscellaneous

Safe body working pressure is 1500 PSI (Quick Exhaust) and 725 PSI (Manual Reset).

INTRINSICALLY SAFE SOLENOID VALVES—THREE-WAY, TWO-POSITION, UNIVERSAL, MANUAL RESET

Part Number	Valve Type	Port Size NPTF	Orifice Size	Valve Materials Seal/Body	Operating Pressure Differential (PSI)	Flow Rate Cv/SCFM*	Minimum Ambient Temp. °F/°C	Maximum Fluid Temp. °F/°C	Valve Weight lbs.	Const. Ref.
U033X5156	3W,U	1/4"	5mm	FKM/S.Steel	0-150	.63/24.5	-13/-25	165/75	1.81	81

* Measured at 90 PSI with a 15 PSI differential. Safe body working pressure 725 PSI.

Note: This valve must be used with I.S. coils 492335 or 490860 only

INTRINSICALLY SAFE SOLENOID VALVES—THREE-WAY, TWO-POSITION, QUICK EXHAUST

Part Number	Valve Type	Port Size NPTF	Orifice Size		Valve Materials Seal/Body	Operating Pressure Differential	Flow Rate				Minimum Ambient Temp. °F/°C	Maximum Fluid Temp. °F/°C	Valve Weight lbs.	Const. Ref.
			P	E			Cv		SCFM*					
							P	E	P	E				
U131E0391	3W, NC	1/4"	3/32	1/4	FKM, NBR/Brass	1.5-105	0.29	1.1	8	39	+14/-10	165/75	1.32	82

* Measured at 90 PSI with a 15 PSI differential. Safe body working pressure 1500 PSI.

Note: This valve functions with coils 490860, 482660 or 483330.01 only.

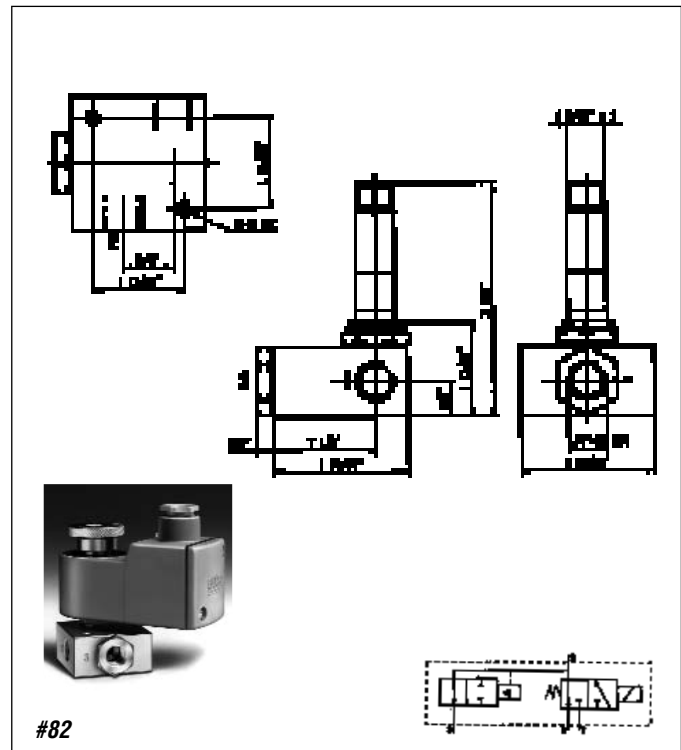
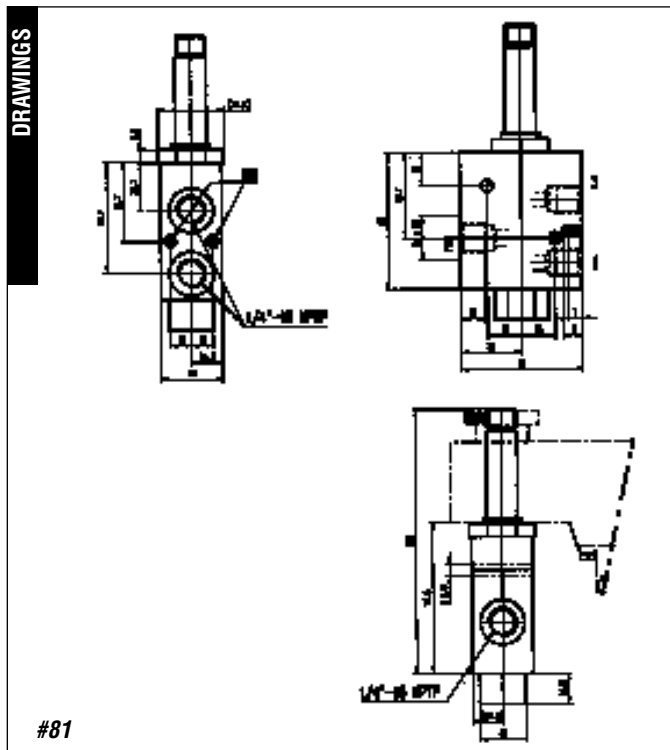

SKINNER Intrinsically Safe Series Four-Way Two-Position Valves

SPECIFICATIONS

Mechanical Characteristics

Standard Materials of Construction

- Body—Aluminum
- Seals—FKM, NBR.

Compatible Fluids

- Air and inert gases.

Electrical Characteristics

- Based on coil selected. See catalog pages 102-106 for detailed electrical information.

INTRINSICALLY SAFE SOLENOID VALVES—TWO-POSITION

Part Number	Valve Type	Port Size NPTF	Orifice Size	Valve Materials Seal/Body	Operating Pressure Differential (PSI)	Flow Rate Cv/SCFM*	Minimum Ambient Temp. °F/°C	Maximum Fluid Temp. °F/°C	Valve Weight lbs.	Const. Ref.
U341B3490	4-way 4-ported	1/4"	1/4"	FKM, NBR/ Aluminum	15-150	0.7/24	+14/-10	165/75	1.28	83
U341L2190	4-way 5-ported	1/2"	9/16"	FKM, NBR/ Aluminum	7-150	4/175	+14/-10	165/75	3.75	84
U341L4190	4-way 5 ported	1" BSP	1"	FKM, NBR/ Aluminum	15-150	10.5/390	+14/-10	165/75	9.03	85
U347L1190	4-way 5-ported 2-solenoid	1/4"	5/16"	NBR/ Zamak (Zinc alloy)	15-150	1.4/54	+14/-10	165/75	2.04	86

* Measured at 90 PSI with a 15 PSI differential. # Other diaphragm material available upon request.

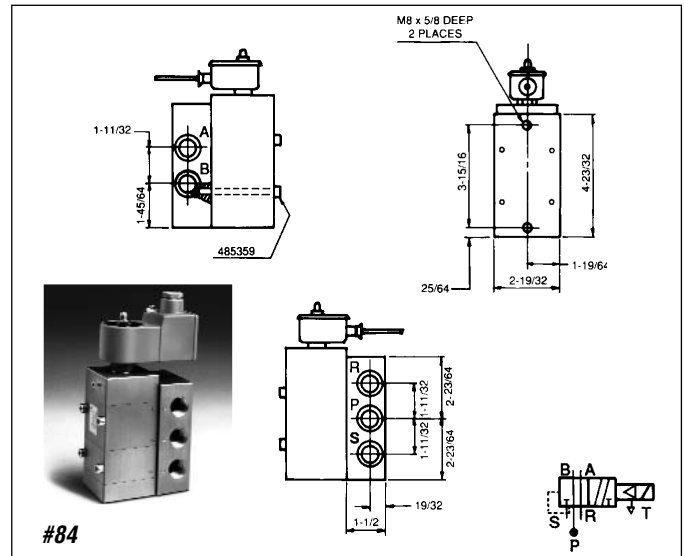
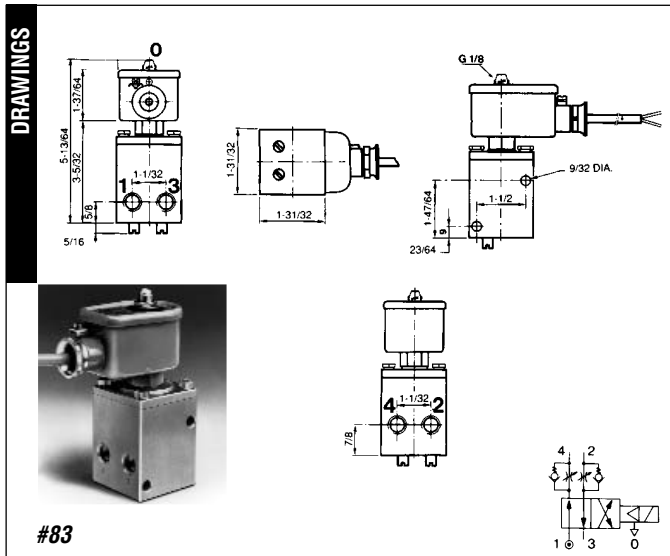

Intrinsically Safe Series

INTRINSICALLY SAFE COIL AND ENCLOSURE INFORMATION

IMPORTANT: The intrinsically safe supply circuit should have enough capacity in all environmental and system conditions to insure delivery of at least the minimum specified operating current of the coil. Be sure to include the internal coil resistance and the bridge rectifier resistance (where applicable) when calculating circuit parameters.

Splice Box Enclosure with Strain Relief Egress Specifications

Protection Class

- IP 65 according to DIN 40050 and IEC 529 standards. Equivalent to NEMA 4 Watertight.

Construction

- Polyamid with fiberglass enclosure and cover.

Electrical Entry and Connections

- Cable entry through a blue cable gland M20 X 1.5. Screw terminals for leads 3 x 1.5mm². Additional ground connection possible with external screw terminal.

Enclosure

- Coil, printed circuit and other parts for I.S. specifications are completely encapsulated within the enclosure using epoxy material.

Dielectric Strength

- Greater than 500 V rms

Bridge Rectifier Resistance

- Less than 50 ohms at 29mA

Coil Internal Resistance

- 295 ohms at 20°C

Voltage

- 24 VDC nominal

Minimum Operating Current

- 29 milliamps

Coil Temperature Rise

- Less than 5°C

Maximum Enclosure Temperature

- <85°C (corresponding to T6 class) according to CENELEC-EN 50014.

Ambient Temperature

- -13°F to + 149°F (-25°C to +65°C)

F.M. Entity Parameters

- $V_{max} = 30$ volts
- $I_{max} = 100$ mA
- $C_i = 0$
- $L_i = 0$ mH

Options

- 1/2" NPT Conduit Hub Adaptor. Order part number U22-001.

Reference Number	Approvals	Classification
490885	LCIE/FM/CSA	Class I, Div. 1, Grps A,B,C,D, Class II, Div. 1, Grps E,F,G
488650.01	LCIE 02 ATEX 6024X	EEx ia IIC T6
488650.03	AUS EX 137X	Ex ia IIC T6

Electrical Parts

DRAWINGS

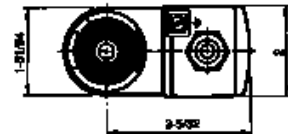
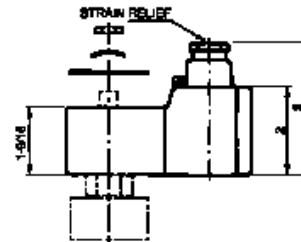

#67

Intrinsically Safe Series

Potted Lead Wire Coil with Strain Relief Egress Specifications

Protection Class

- IP 67 according to DIN 40050 and IEC 529 standards. Equivalent to NEMA 4 Watertight.

Construction

- Epoxy coated metal enclosure and cover.

Electrical Entry and Connections

- Fixed and potted two core (2 x 1mm²) blue connection cable of 2m length. Other cable lengths on request. Entry cable gland pg 11 (18.6mm) (DIN 46320). Additional ground connection possible with external screw terminal.

Enclosure

- Coil, welded lead connections, printed circuit and other parts for I.S. specifications are completely encapsulated within the enclosure using epoxy material.

Dielectric Strength

- Greater than 500 V rms

Bridge Rectifier Resistance

- Less than 50 ohms at 29mA

Coil Internal Resistance

- 295 ohms at 20°C

Voltage

- 24 VDC nominal

Minimum Operating Current

- 29 milliamps

Coil Temperature Rise

- Less than 5°C

Maximum Enclosure Temperature

- <85°C (corresponding to T6 class) according to CENELEC-EN 50014.

Ambient Temperature

- -40°F to + 149°F (-40°C to +65°C)

F.M. Entity Parameters

- $V_{max} = 30$ volts
- $I_{max} = 100$ mA
- $C_i = 0$
- $L_i = 0$ mH

Options

- 1/2" NPT Conduit Hub Adaptor. Order part number U22-003.

Reference Number	Approvals	Classification
490890 (VZ1300)	LCIE/FM/CSA	Class I, Div. 1, Grps A,B,C,D Class II, Div. 1, Grps E,F,G
488660.01	LCIE 02 ATEX 6024X	EEx ia IIC T6
488660.03	AUS EX 137X	Ex ia IIC T6

* Note: According to CENELEC

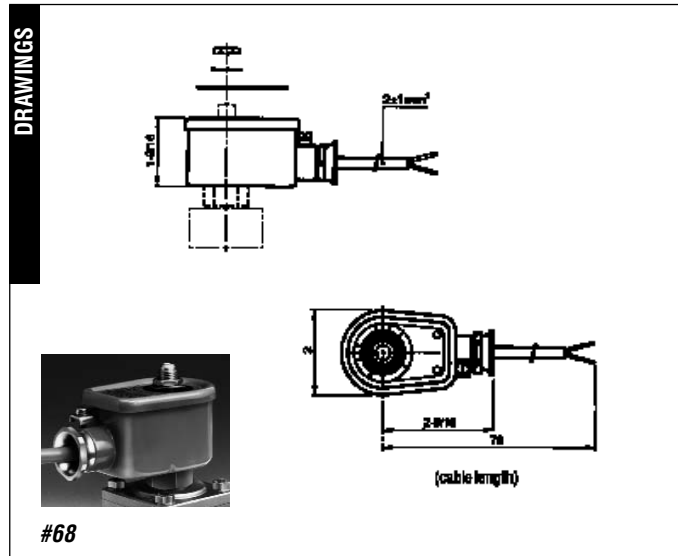

Intrinsically Safe Series

Potted Coil with DIN Connection and DIN Plug Adaptor Specifications

Protection Class

- IP 65 according to DIN 40050 and IEC 529 standards (with DIN plug). Equivalent to NEMA 4 Watertight.

Construction

- Epoxy coated metal enclosure and cover.

Electrical Entry and Connections

- Blue "DIN" standard plug interface and 3-pin AMP plug (DIN 43650 type A) with blue pg 9 gland (15.2mm)

Enclosure

- Coil, printed circuit and other parts for I.S. specifications are completely encapsulated within the enclosure using epoxy material.

Dielectric Strength

- Greater than 500 V rms

Bridge Rectifier Resistance

- Less than 50 ohms at 29mA

Coil Internal Resistance

- 295 ohms at 20°C

Voltage

- 24 VDC nominal

Minimum Operating Current

- 29 milliamps

Coil Temperature Rise

- Less than 5°C

Maximum Enclosure Temperature

- <85°C (corresponding to T6 class) according to CENELEC-EN 50014.

Ambient Temperature

- 13°F to + 149°F (-25°C to +65°C)

F.M. Entity Parameters

- $V_{max} = 30$ volts
- $I_{max} = 100$ mA
- $C_i = 0$
- $L_i = 0$ mH

Options

- 1/2" NPT DIN Plug Adaptor. Order part number U27-001.

Reference Number	Approvals	Classification
490895 (VZ2000)	LCIE/FM/CSA	Class I, Div. 1, Grps A,B,C,D Class II, Div. 1, Grps E,F,G
488670.01	LCIE 20 ATEX 6024X	EEx ia IIC T6

Electrical Parts

DRAWINGS

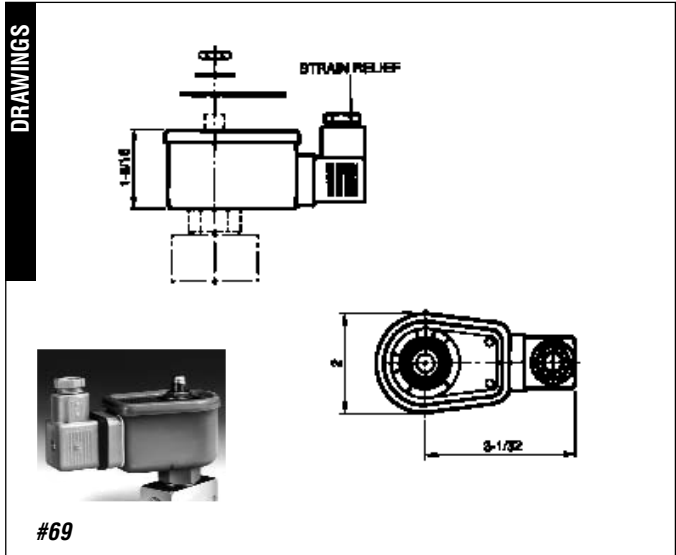

Intrinsically Safe Series

32mm DIN Coil and Plug Adaptor Specifications

Protection Class

- IP 65 according to DIN 40050 and IEC 529 standards (with DIN plug). Equivalent to NEMA 4 Watertight.

Construction

- Fully encapsulated assembly comprising a coil, integral magnetic iron path, three diodes circuit and DIN plug connection. The encapsulation provides an effective compact enclosure offering full protection against dust, oil, water etc.

Electrical Entry and Connections

- The coil is connected with a 3-pin plug pg 9 gland (part number 486586) according to DIN 43650 type A.

Dielectric Strength

- Greater than 500 V rms

Coil Internal Resistance

- 340 ohms at 20°C

Voltage

- 24 VDC nominal

Minimum Operating Current

- 35 milliamps

Coil Temperature Rise

- Less than 5°C

Maximum Enclosure Temperature

- <85°C (corresponding to T6 class) according to CENELEC-EN 50014.

Ambient Temperature

- 13°F to + 131°F (-25°C to +55°C)

F.M. Entity Parameters

- $V_{max} = 30$ volts
- $I_{max} = 100$ mA
- $C_i = 0$
- $L_i = 0$ mH

Options

- 1/2" NPT DIN Plug Adaptor. Order part number U27-001.

Reference Number	Approvals	Classification
490880	With Din Plug*	Class I, Div. 1, Grps A,B,C,D Class II, Div. 1, Grps E,F,G
483580.01	Without DIN Plug,**	EEx ib IIC T6
483960.01	With DIN plug,**	EEx ia IIC T6

* LCIE/FM/CSA PENDING
** LCIE 20 ATEX 6065 X

Electrical Parts

DRAWINGS

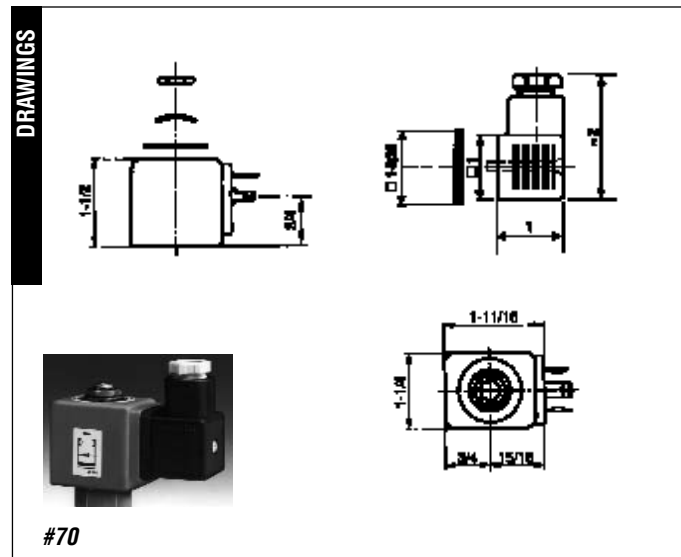

Intrinsically Safe Series

Splice Box Enclosure with Booster Circuit and Strain Relief Egress Specifications

Protection Class

- IP 65 according to DIN 40050 and IEC 529 standards. Equivalent to NEMA 4 Watertight.

Construction

- Polyamid with fiberglass enclosure and cover.

Electrical Entry and Connections

- Screw terminals within terminal box. Cable connection through M20x1.5 cable gland. Additional ground connection possible with external ground terminal.

Enclosure

- Coil, printed circuit and other parts for I.S. specifications are completely encapsulated within the enclosure using epoxy material.

Booster Circuits

- The electronic booster circuit consists of capacitor, diodes, thyristor and Zener diode.

Voltage

- Nominal: 24 VDC nominal
- Maximum: 28 VDC
- Minimum at Attraction: 21.6 VDC*
- * *Circuit design must ensure that at least 21.6 VDC is available at the solenoid for proper operation.*

Minimum Holding Current

- 60 mA

Coil Temperature Rise

- Less than 5°C

Maximum Enclosure Temperature

- <85°C (corresponding to T6 class) according to CENELEC-EN 50014.

Ambient Temperature

- 13°F to + 140°F (-25°C to +60°C)

Required Time Delay for Renewed Valve Actuation after Booster Discharge

- Approximately 1 second at nominal voltage

Duty Cycle

- 100% solenoid duty

Options

- 1/2" NPT Conduit Hub Adaptor. Order part number U22-001.

Electrical Parts	Reference Number	Approvals	Classification
	490860	FM CSA	Class I, Div. 1, Grps A,B,C,D Class II, Div. 1, Grps E,F,G
	482660	LCIE 02 ATEX 6024X	EEx ib IIB T6
	483330.01	LCIE 02 ATEX 6024X	EEx ia IIC T6

* Note: According to CENELEC

Acceptable Barriers Include:

MTL	3022
MTL	779
STAHL	9001/01-280/110/10
STAHL	9001/01-280/100/10
STAHL	9001/01-280/165/10
STAHL	9001/03-280/000/00
STAHL	9002/13-280/100/04
STAHL	9002/13-280/110/00

DRAWINGS

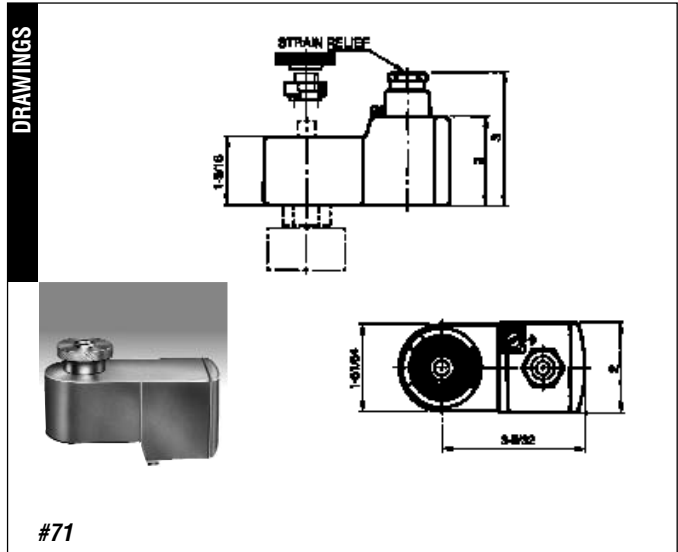

SKINNER Intrinsically Safe Series Four-Way Two-Position Valves

Hazardous (Classified) Locations

(In accordance with Article 500, National Electrical Code-1984)

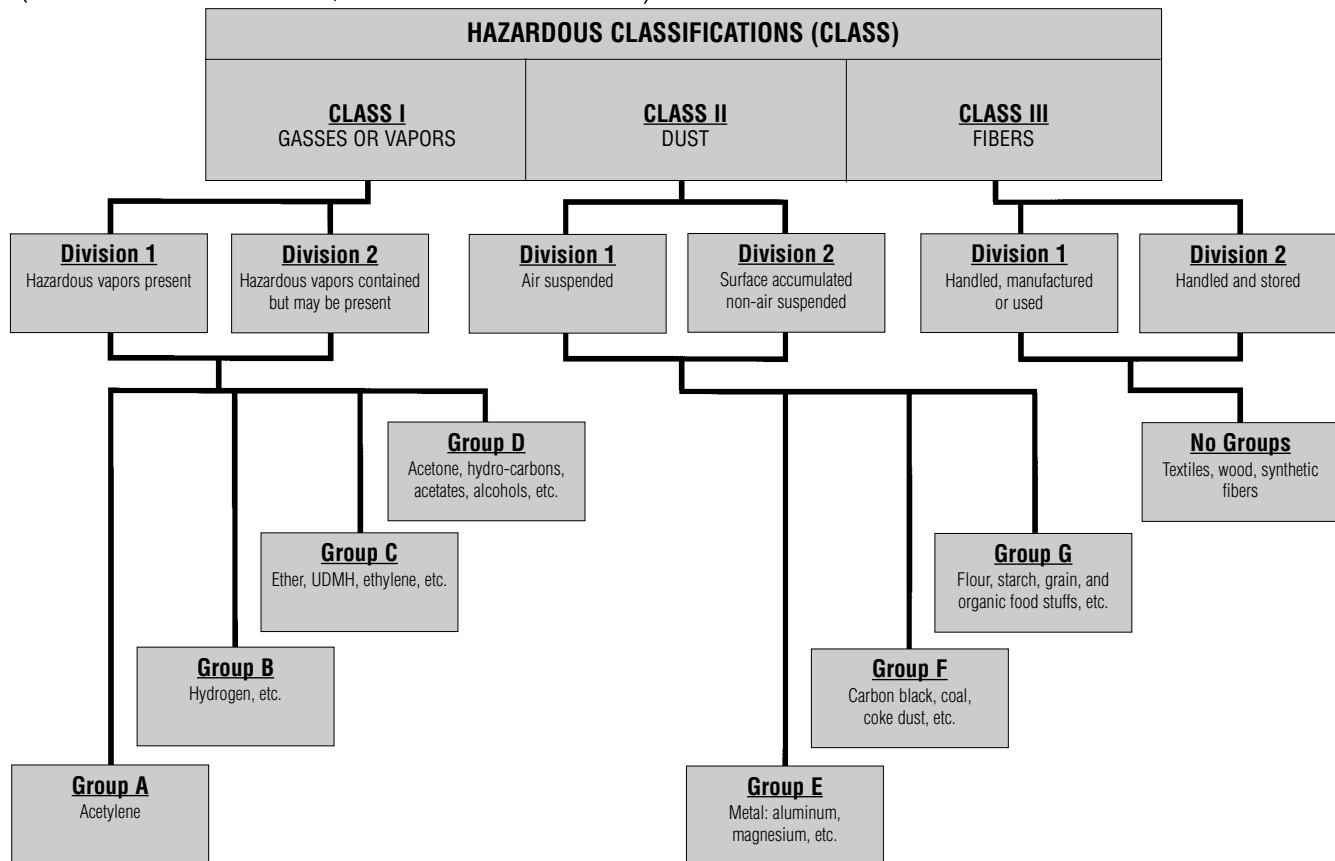

Hazardous Atmosphere Classifications

Typical Gases in Atmosphere Class I	UK and CENELEC (BS5501: Part 1 EN 50 014)	US National Electrical Code Group
Ethane, propane, butan, pentane, hexane, heptane, octane, nonane, decane, acetic acid, acetone, methanol, toluene, ethylacetate	IIA	Group D
Ethylene, Coke, oven gas, dimethyl ether, diehylether, ethylene oxide	IIB	C
Hydrogen	IIC	B
Carbon Disulphide		No Classification
Acetylene		A
Ethyl Nitrate		No Classification

Typical Dusts in Atmosphere Class I	UK and CENELEC (BS5501: Part 1 EN 50 014)	US National Electrical Code Group
Metal	No Classification	E
Carbon/Coal		F
Grain		G

Surface Temperature/Agency Code Cross Reference

Maximum Surface Temperature	US Standard (U.L.)	CENELEC
450°C	T1	T1
300°C	T2 T2a - 280°C T2b - 260°C T2c - 230°C T2d - 215°C	T2
200°C	T3 T3a - 180°C T3b - 165°C T3c - 160°C	T3
135°C	T4 T4a - 120°C	T4
100°C	T5	T5
85°C	T6	T6

Hazardous Area Classifications

Description	US	CENELEC
An explosive atmosphere is continuously present	Division I	Zone 0
An explosive atmosphere is intermittently present during normal operations	Division I	Zone 1
An explosive atmosphere is present during abnormal conditions	Division II	Zone 2

NOTE: These charts are provided for reference only. Consult the U.S. National Electrical Code or rating agencies such as Factory Mutual or Underwriter's Laboratories for specific details.

SKINNER A-10 Series

High Pressure Two- and Three-Way Direct Acting Hydraulic Valves

SPECIFICATIONS

Mechanical Characteristics

Standard Materials of Construction

- Body—Stainless Steel (430F)
- Seals—Metal
- Flange Seal—NBR
- Sleeve—Stainless Steel (304)
- Plunger—Stainless Steel (430FR)
- Stop—Stainless Steel (430FR)
- Springs—Stainless Steel (18-8)
- Shading Ring—Copper (AC only)
- Spool—Stainless Steel (17-4PH)

Compatible Fluids

- Hydraulic Fluids.

Product Description

Skinner 2-way and 3-way A-10 Series valves are designed for use in high-pressure systems applications up to 3000 PSI. In addition to being available in pipe mounting configurations, A-10 valves are available in several custom mounting configurations including manifold, flange, and cage or cartridge mounted products.

Electrical Characteristics

Voltagess

- DC—12, 24, 120
- AC—24/60, 120/60, 240/60

Power Consumption

- 14 watts DC
- 21 watts AC

Miscellaneous

Operating Speed

- Up to 300 cycles per minute.

Response Time

- AC—Approximately 4-8 milliseconds to open or close.
- DC—Approximately 15-30 milliseconds to open, 15-25 milliseconds to close.

Leakage

- Internal—Maximum of 295cc/min. at 3000 PSI and 70°F with Mil-H-5606 oil.
- External—None.

Valve Construction Alternatives

Coil Type

- Class B molded leaded

Enclosure Type

- 1/2" NPT conduit enclosure

Flow Limits

- The spool in A10 Series valves will fail to shift when flow exceeds the maximum rated value. Each catalog listing indicates the flow and pressure drop for which these valves will operate without malfunction. The static pressure listed for each valve will not adversely affect valve operation as long as the rated flows and pressure differentials are not exceeded. The maximum flows (GPM) and pressure differentials (PSI) are based on Mil-H-5606A hydraulic oil at 80°F.

Mounting

- Manifold, flange and cage types available. Consult factory for details.

TWO WAY TYPE A12 AND A126 STAINLESS STEEL VALVES—NORMALLY CLOSED

NPT Pipe Size	Effective Orifice Diameter	Average Cv Factor	Static Pressure Rating (PSI)		Max. Pressure Differential (PSI)	Maximum Flow (GPM)	Inlet Port	Outlet Port	Class B Molded Coil 1/2" NPT Conduit Enclosure	Const. Ref.
			AC	DC						
1/8"	3/32	0.15	3000		3000	8.5	1	2	A12LB13002	134
	3/32	0.15		3000	3000	8.5	1	2	A126LB13001	134

TWO WAY TYPE A11 AND A116 STAINLESS STEEL VALVES—NORMALLY OPEN

NPT Pipe Size	Effective Orifice Diameter	Average Cv Factor	Static Pressure Rating (PSI)		Max. Pressure Differential (PSI)	Maximum Flow (GPM)	Inlet Port	Outlet Port	Class B Molded Coil 1/2" NPT Conduit Enclosure	Const. Ref.
			AC	DC						
1/8"	3/32	0.15	3000		3000	9	3	2	A11LB13002	134
	3/32	0.15		3000	3000	9	3	2	A116LB13001	134

A-10 Series High Pressure Three-Way Direct Acting Hydraulic Valves

THREE WAY TYPE A13, A136 STAINLESS STEEL VALVES—NORMALLY CLOSED

NPT Pipe Size	Effective Orifice Diameter	Average Cv Factor	Static Pressure Rating (PSI)		Max. Pressure Differential (PSI)	Maximum Flow (GPM)	Inlet Port	Outlet Port	Class B Molded Coil 1/2" NPT Conduit Enclosure	Const. Ref.
			AC	DC						
1/8"	3/32	0.15	3000		1000	5.7	1	2	A13LB13002	87
	3/32	0.15	3000		2000	7	2	3	A13LB13002	87
	3/32	0.15		3000	1000	5.7	1	2	A136LB13001	87
	3/32	0.15		3000	2000	7	2	3	A136LB13001	87

THREE WAY TYPE A15 AND A156 STAINLESS STEEL VALVES—NORMALLY OPEN

NPT Pipe Size	Effective Orifice Diameter	Average Cv Factor	Static Pressure Rating (PSI)		Max. Pressure Differential (PSI)	Maximum Flow (GPM)	Inlet Port	Outlet Port	Class B Molded Coil 1/2" NPT Conduit Enclosure	Const. Ref.
			AC	DC						
1/8"	3/32	0.15	3000		3000	9	3	2	A15LB13002	87
	3/32	0.15	3000		3000	8.5	2	1	A15LB13002	87
	3/32	0.15		3000	3000	9	3	2	A156LB13001	87
	3/32	0.15		3000	3000	8.5	2	1	A156LB13001	87

THREE WAY TYPE A16 AND A166 STAINLESS STEEL VALVES—DIRECTIONAL CONTROL

NPT Pipe Size	Effective Orifice Diameter	Average Cv Factor	Static Pressure Rating (PSI)		Max. Pressure Differential (PSI)	Maximum Flow (GPM)	Inlet Port	Outlet Port	Class B Molded Coil 1/2" NPT Conduit Enclosure	Const. Ref.
			AC	DC						
1/8"	3/32	0.15	3000		2000	7	2	3	A16LB13002	87
	3/32	0.15	3000		2000	7	2	1	A16LB13002	87
	3/32	0.15		3000	2000	7	2	3	A166LB13001	87
	3/32	0.15		3000	2000	7	2	1	A166LB13001	87

#87

Port Identification:

A13	A15	A16
1-IN	Exhaust	NC
2-Cylinder	Cylinder	IN
3-Exhaust	IN	NO

#134

Port Identification:

A11	A12
1-Plugged	1-IN
2-OUT	2-OUT
3-IN	3-Plugged

SKINNER MB Series Three-Way Direct Acting Valves

SPECIFICATIONS

Product Description

MB Series valves are designed for the actuation of small air cylinders and clamps, and are suited for applications requiring low air flow.

The valves are direct acting, multipurpose valves with all ports in the body. The valve body is molded from plastic, while the internal parts are nylon, polyester and stainless steel. The valves will operate at up to 150 PSI, consuming only 4 watts per coil on AC operation, 5 watts per coil on DC.

Functional design flexibility is assured given the wide variety of available valve configurations. The listed accessories enable the user to customize MB Series valves as 2-way normally open or normally closed by plugging one port; 3-way normally open, normally closed or directional control; and 4-way normally closed-normally open, normally open-normally open, and normally closed-normally closed.

Mechanical Characteristics

Standard Materials of Construction

- Body—Plastic
- Seals—NBR
- Sleeve—Stainless Steel (304)
- Plunger—Stainless Steel (430FR)
- Stop—Stainless Steel (430FR)
- Springs—Stainless Steel (17-7PH)
- Shading Ring—Copper (AC valves only)
- Manifold Bases—Zinc

Compatible Media

- Lubricated Air, Non-Lubricated Air, and Inert Gases compatible with materials of construction.

Electrical Characteristics

Voltages

- DC—12, 24, 120
- AC—24/60, 120/60, 240/60

Power Consumption

- 4 watts AC per coil
- 5 watts DC per coil

Miscellaneous

Operating Speed

- Up to 1000 cycles per minute.

Response Time

- AC—Approximately 3-12 milliseconds to open, 5-16 milliseconds to close.
- DC—Approximately 8-14 milliseconds to open, 5-15 milliseconds to close.

Leakage

- Internal—Maximum 3 SCCM at 150 PSI.
- External—None.

Standard Valve Construction

Coil Type

- Class A taped with lead

Enclosure Type

- Slotted enclosure for leaded coils.

DIRECT ACTING THREE-WAY VALVES AND FOUR-WAY VALVE ASSEMBLIES

Pipe Size	Orifice Diameter		Cv Factor		Operating Pressure (PSI)		Wattage		Class A Taped Leaded Coil	Const. Ref.
	NC Port	NO Port	NC Port	NO Port	Minimum	Maximum	AC	DC		
#10-32 Ports	3/64	3/64	0.032	0.028	0	150	4	5	MBD002	88
Manifold Mounted	3/64	3/64	0.032	0.028	0	150	4	5	MBD005	88
1/8 NPT 4 Way Assembly	3/64	3/64	0.032	0.028	0	150	8	10	MBD009	89

MB Series Three-Way
Direct Acting Valves

DRAWINGS

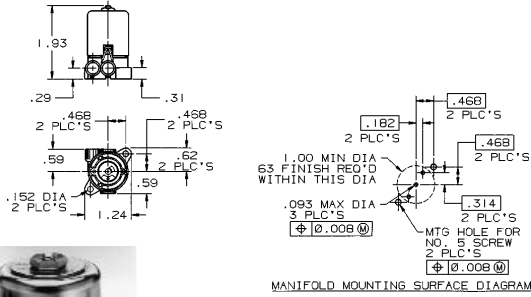

#88

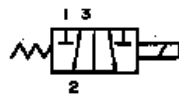
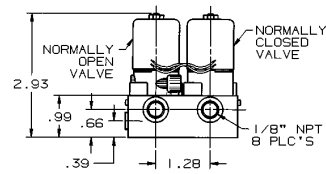
 Port Identification:
1-NC/2-Common/3-NO

#89

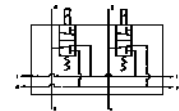
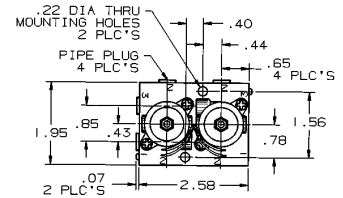
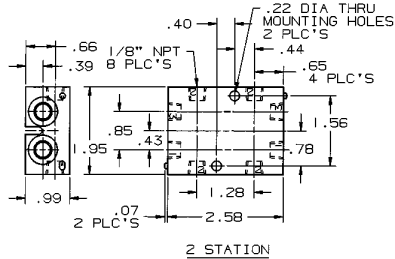
 Port Identification:
1-IN/2-Cylinder/3-Exhaust

#90

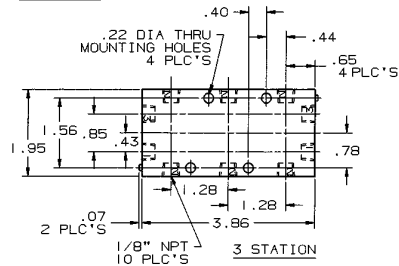

Valve Accessories

Accessories	Contents	Part Number
2-Station Manifold Base Kit (for mounting 2 valves)	4 Pipe plugs 4 No. 5 self tapping screws	MB-60-S001
3-Station Manifold Base Kit (for mounting 3 valves)	5 Pipe plugs 6 No. 5 self tapping screws	MB-60-S002
Manifold Interface Kit (connects 2 manifold bases)	1 No. 8 screw 2 "O" rings	MB-60-S003
Manifold Blank Station Kit (for sealing an unused station)	1 Plate 2 "O" rings 2 Screws	MB-60-S004
2-Station Manifold Base const. ref. 90	1 MB-01-003 manifold block 2 V1-31-254 nuts assembled	MB-60-S005
3-Station Manifold Base const. ref. 90	1 MB-01-004 manifold block 2 V1-31-254 nuts assembled	MB-60-S006

 Ordering Instructions for
Multiple Station Manifolds

Step 1: Determine the number of valve stations required. This will equal the number of subbase valves to order (MBD005).

Step 2: Select the combination of two- and three-station manifolds that sum to equal the number of valve stations required (i.e. five stations total = one three-station and one two-station manifold).

Step 3: Choose the accessory kits required to complete the system and determine if you want the valves assembled to the manifolds at the factory.

Step 4: Specify the required voltage.

Example:

- 1) You have selected a valve which is to be manifolded.
- 2) Your system requires a five-station manifold (i.e. one three-station manifold attached to one two-station manifold).
- 3) You require the manifold bases and an interface kit. You decide to assemble the valves and manifolds. If they were to be assembled by the factory, there would be a price-add.

- 4) Your system is 120/60 watts AC: Your order should read:
- 5-MBD005, 120/60
1-MB-60-S001
1-MB-60-S002
1-MB-60-S003
1-MB-60-S005
1-MB-60-S006

EPP3 Electropneumatic Pressure Regulator

SPECIFICATIONS

Fluid

- Lubricated or non-lubricated air and neutral gases recommended filtration: 25-50u

Temperature Range

- Ambient -10°F (0 to 50°C)
- Fluid -10°F (0 to 50°C)

Inlet Pressure Range

- 15 to 175 PSI (1 to 12 bar). The inlet pressure must always be at least 15 PSI above the regulated pressure value.

Outlet Pressure Range

- 3 to 150 PSI (0.2 to 10 bar)

Hysteresis

- 1.5 PSI (-100 mbar). Factory set up.

Linearity

- 1% f.s.o.

Air Consumption at Constant Control Signal

- 0

Voltage

- 24 VDC + 15% (Max. ripple 1 V)

Power Consumption

- Max. 6 W with 24 VDC and constant changes of the control signal; <1W without change of control signal.

Control Signal

- U=Analog 0-10V Impedance:10k
- I=Analog 4-20 mA Impedance:0.5k

Outlet Sensor Signal

- A)** Proportional pressure outlet signal 0-10 V from integrated sensor (recommended load resistance 0.5k)
- B)** Proportional pressure outlet signal 4020 mA from integrated sensor (recommended load resistance 0.5 k)
- C)** "Alarm" output signal 0/24 V with adjustable triggering level. (Difference between control signal and sensor pressure signal). (Imax = 40 mA)

- Factory set-up: Diff. signal = + 0.8 V to + 1 V
- Possible set-up: Diff. signal = + 0.1 V to + 5 V

To neutralize the alarm output signal during the control signal changes, the use of a synchronized time lag relay is required.

Indicative Response Time

- With a volume of 330 cm³ at the outlet of the regulator.
 - Filling: 29 to 72 PSI (2 to 4 bar) 29 to 116 PSI (2 to 8 bar)
 - Step Response: -60 ms -120 ms
 - Emptying: 72 to 29 PSI (4 to 2 bar) 116 to 29 PSI (8 to 2 bar)
 - Step Response: -70 ms -130 ms

Safety Position

- In case of control failure or if it is less than 1% of its full scale value, the regulated pressure drops automatically to 0 bar (atmospheric pressure). In case of voltage supply failure, the regulated pressure will be kept constant (with eventual discrepancy due to loss of pressure in the servo-chamber).

Electrical Connection

- 4 Screw terminals under the protection cover with Pg 13.5 cable gland or through DIN 43651 connector (6 P+E).

Life Expectancy

- >50 Million changes of control signal steps. NOTE: It is compulsory to set the control signal at 0 V or 4 mA each time the air pressure supply is turned off (during the night or weekend). When the air pressure supply cannot be fully exhausted, it is necessary to assure that the deviation between the control value and the inlet pressure remains smaller than 15 PSI (1 bar).

Mounting position

- Indifferent (recommended position: upright; electronic part on top).

Resistance to Vibration

- 30 g in all directions

Degree of Protection

- IP 65 (Equivalent to NEMA 4).

External Sensors

- All pressure sensors with the following characteristics are compatible with the EP-transducer.
 - Sensitivity: 15 PSI (0.5 V/bar) up to 15 PSI (10 V/bar)
 - Zero Offset: 15 PSI (-3 V/bar) to 15 PSI (10 V/bar)

Assembly

- Silicone free

Electromagnetic Compatibility

- In accordance with IEC 801-4 part 4 standards.

Typical Applications

- Paint spraying equipment
- Robotic welding
- Brake and clutch control

SUMMARY OF TYPES

	Pressure Range (PSI)	Connection NPT	With Integrated Pressure Sensor	Entry option for External Sensor Signal		Outlet Signal Option			Electrical Connection	
				Feedback Signal		Without	0-10 V	0-10 V	DIN 43651 Connector	Cable Gland Pg 13.5
				0-10 V	4-20 mA					
EPP3J0	21 U/1 100 10	150	1/4	x		x				x
	21 U/1 600 10	150	1/4	x			x			x
	21 U/1 700 10	150	1/4	x				x		x
EPP3J0	23 U/1 130 10	150	1/4		x	x				x
	24 U/1 130 10	150	1/4			x				x
EPP3J0	41 U/1 100 10	150	1/2	x		x				x
	41 U/1 600 10	150	1/2	x			x			x
	41 U/1 700 10	150	1/2	x				x		x
EPP3J0	43 U/1 130 10	150	1/2		x	x				x
	44 U/1 130 10	150	1/2			x				x

FLOW DATA

Outlet Pressure in Function of Flow at Constant Control Signal ($P_1 = 10$ bar)

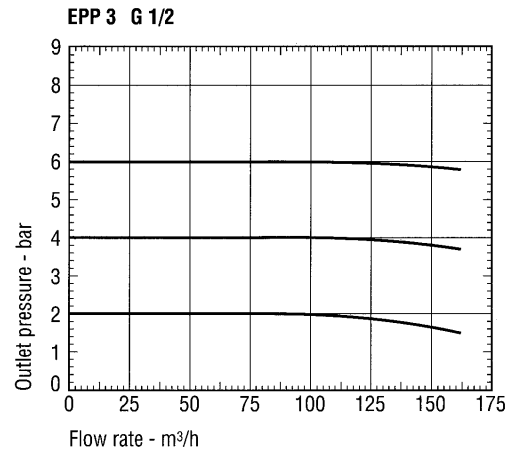
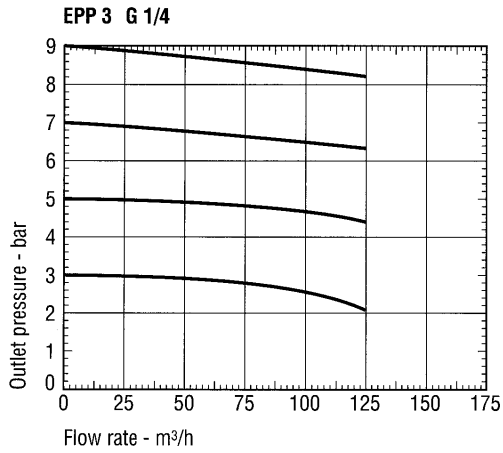

HYSTERESIS DIAGRAM

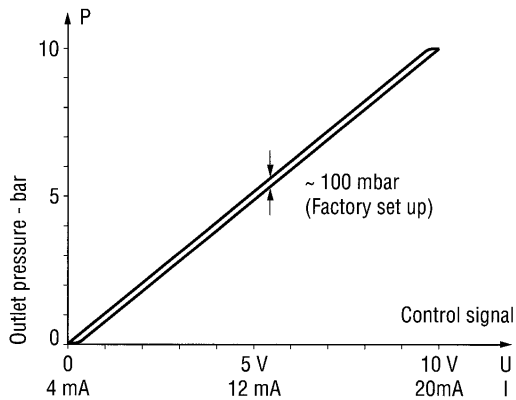

**EPP3JC...130/600/700... with
DIN circular plug-in connection
6 P + E (connector included)**

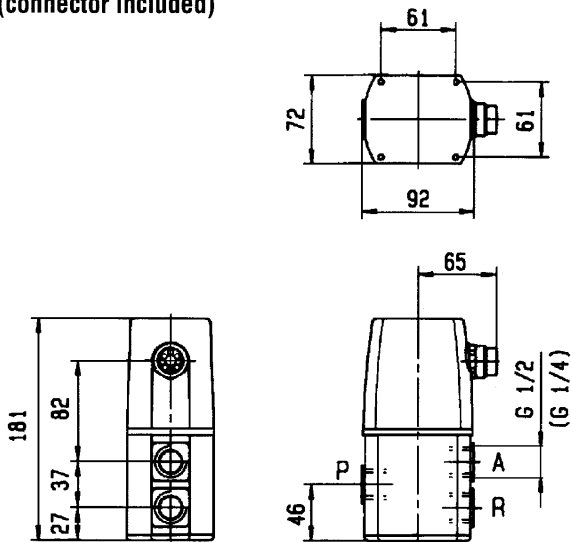

Technical Information

Introduction

Solenoid valves are highly engineered products which can be utilized in many diverse and unique fluid system applications. In addition to operational functionality, selecting the best product for a given application must also consider safety, reliability, media compatibility and suitability for the operating environment. This section provides a brief overview of the components and functional varieties of solenoid valves available from Fluid Control Division. A more detailed and complete discussion on solenoid valve technology is provided in the Skinner Valve Technical Reference Manual.

General Information

Valve Construction and Basic Operation

A solenoid valve is operated by opening or closing an orifice in the valve body which permits or prevents flow through the valve. The orifice is opened or closed through the use of a plunger that is raised and lowered within a sleeve tube by energizing a solenoid. The bottom and/or top of the plunger contain soft elastomeric seals, which close off the orifice in the body or the stop respectively.

The solenoid assembly consists of a coil, plunger and sleeve assembly. In a normally closed valve a plunger return spring holds the plunger against the orifice, preventing flow through the valve. When current flows through the coil, a magnetic field is produced which turns the stop into an electromagnet that attracts the magnetic plunger. This action compresses the return spring, allows the body orifice to open and permits fluid to flow

through the valve.

Effective operation of a solenoid valve is dependent upon the efficiency of the magnetic circuit through which the flux travels. If the flux path is designed with a high level of magnetic efficiency, (i.e., with low resistance), the level of available magnetic force is improved. This is accomplished by the use of magnetically, highly conductive materials throughout the circuit.

Pressure Vessel

The combination of a body, sleeve assembly and plunger make a pressure vessel. The pressure vessel is the device that contains the process fluid. It can be completely enclosed, permitting removal of the enclosure and coil without intruding on the process stream.

The body of a valve contains the inlet and outlet ports and is the part through which flow passes when a valve is open. For most valves the fluid passes through an orifice, which is opened and closed as a result of plunger actuation. Solenoid valves are available in a wide variety of body materials. Brass, stainless steel, aluminum and plastic are some of the materials from which most valve bodies are made. The material for any given application is generally dictated by the operating environment, the process fluid and economics.

The sleeve assembly consists of three parts—the flange, tube, and stop. The flange and stop are made of magnetic material to contain and direct magnetic flux through the plunger. The tube is made of non-magnetic material to make certain that the flux is directed through the plunger rather than around it.

Since the inside surface of the sleeve assembly contacts the process fluid, it is subjected to the same line pressure as the valve body. To provide the required strength and integrity, Skinner utilizes a welded sleeve assembly. In addition to withstanding

high pressures without harm, the welded construction allows the flux gap to be minimized. This increases the efficiency of the magnetic circuit and also allows for high cycle life.

The plunger is always the element that opens and closes a valve. Several different plunger configurations have been developed to support the wide variety of solenoid valve designs required to fill the needs of our customers.

Plunger seals may also be made from a variety of materials. Seal material selection depends on the particular process fluid, fluid temperature, operating pressure differential, leakage rate and cycle life requirements. Typical seal materials are NBR, FKM, Ethylene Propylene (EPDM), Neoprene and PTFE. Skinner Valve also uses a special synthetic gem material (RUBY) in applications of high temperature and/or pressure conditions.

Skinner Valve plunger assemblies, when appropriate, use floating top and bottom seals to enhance valve performance. Floating seals permit the plunger to generate a larger actuation force to open against the pressure differential in the valve. This enables the valve to operate at higher pressure ratings.

Coils and Enclosures

Solenoid valve coils are the heart of the operating mechanism of a valve. A coil is the component of an electromagnet which, when supplied with an electric current (AC or DC), produces a magnetic field. This generates a magnetic force that attracts the plunger.

Solenoid valve coil enclosures perform three important functions. The enclosure is necessary to complete the electromagnetic flux path of the solenoid, provide protection from contact with the coil, and protect the coil against environmental conditions. The coil enclosure may also provide a means for accommodating a variety of electrical connections. Skinner Valve offers enclosures of

Coils are rated by insulation classes that correspond to a maximum allowable coil temperature. The maximum allowable coil temperature is the temperature to which the coil can be exposed without experiencing thermal degradation of the magnet wire insulation. These classes and corresponding maximum temperature levels are:

Class	Nominal Class Temperature	Permissible Temp. by Change of Resistance Method (UL)	Allowable Temp. Rise Above 25°C (77°F) Ambient Temp.
A	105°C (221°F)	110°C (230°F)	85°C (153°F)
B	130°C (266°F)	120°C (248°F)	95°C (171°F)
F	155°C (311°F)	140°C (284°F)	115°C (207°F)
H	180°C (356°F)	160°C (320°F)	135°C (243°F)

Coils meeting Classes F and H are sometimes referred to as "High Temperature Coils". These ratings are summarized graphically in Figure 1.

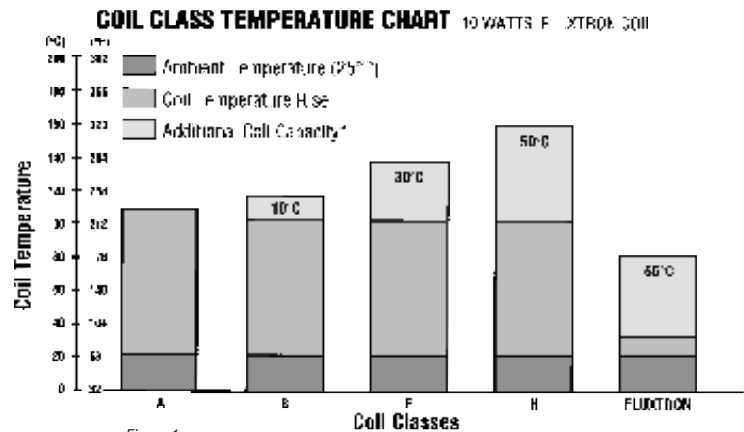

Figure 1

various types to suit most applications.

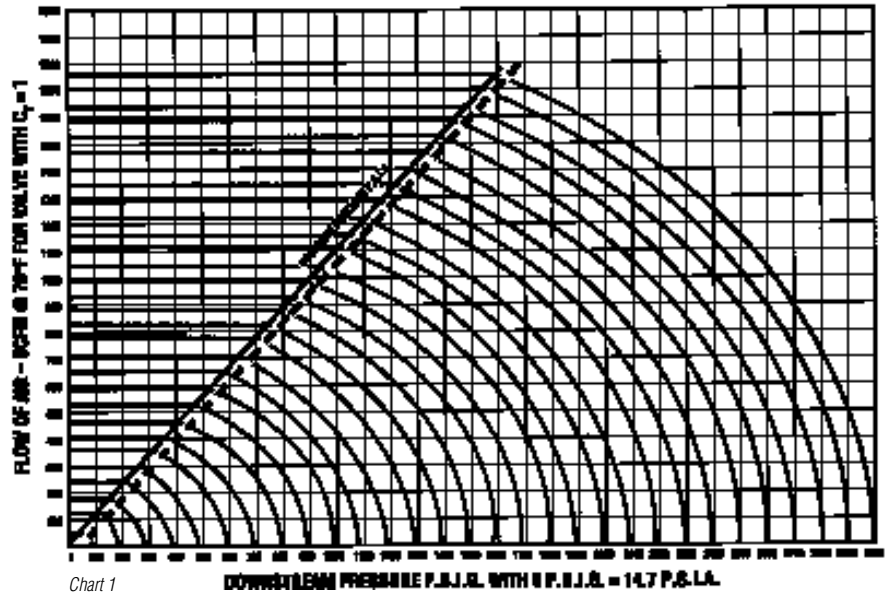

Chart 1

Valve Sizing – Determining the Flow Rate of a Valve*

Air and Gas Service

To properly size a valve for air or gas service, four specific parameters must be known:

- Upstream pressure (inlet pressure to the valve)
- Pressure differential (or downstream pressure, the outlet pressure of the valve)
- Actual flow through the valve in SCFM, or Cv required to yield the desired flow
- The gas that will be flowing through the valve, and its specific gravity

With these parameters known, refer to chart (1) or (2). These charts provide flow (in SCFM) for a valve operating on air with a Cv Factor of 1. The

charts contain identical information, but chart (2) should be used for valves with lower pressure and flow.

Steps to Determine Flow:

- 1) Locate the downstream pressure (outlet pressure, or upstream pressure minus the pressure differential) on the bottom scale of the chart.
- 2) Read vertically up the chart until the downstream pressure intersects the upstream pressure (represented by a family of curved lines.)
- 3) Read horizontally across the graph to the intersection with the left scale, "Flow in SCFM @ 70°F". The value indicated at this point on the scale is the flow of air through a valve with a Cv of 1.
- 4a) To determine the flow of a gas other than air at 70°F, use the correction factors listed below, (Air Flow x Correction Factor = Gas Flow). If the

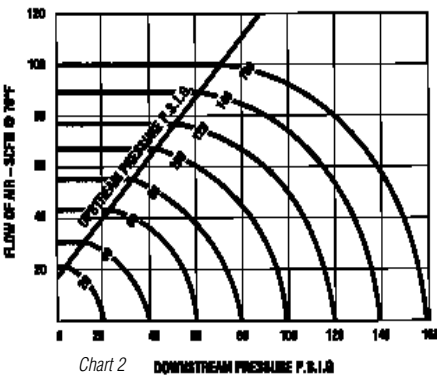

Chart 2

WATER FLOW CHART FOR VALVE WITH Cv FACTOR = 1

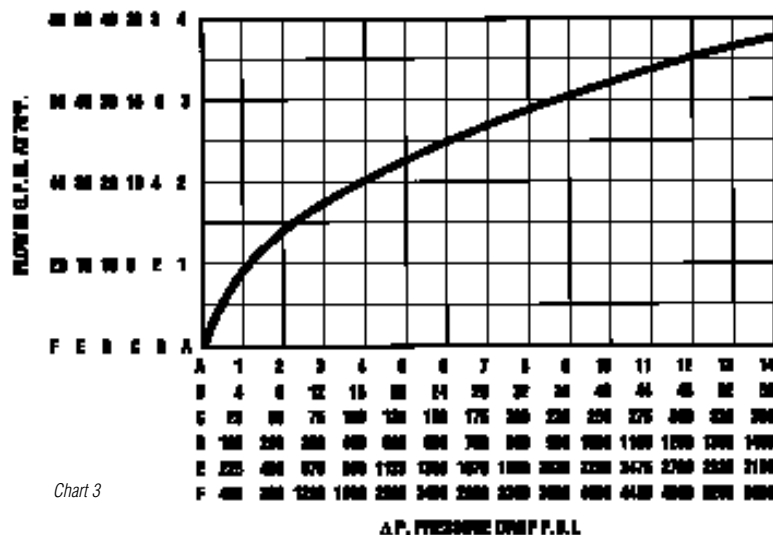

Chart 3

correction factor is not known it can be calculated by using the specific gravity of the gas in the following equation:

Correction Factor = the square root of (1/specific gravity)

Acetylene	1.05
Ammonia	1.30
Argon	0.85
Hydrogen	3.79
Methane	1.34
Neon	1.20
Nitrogen	1.02
Oxygen	0.95

4b) For selection of a valve with a different flow, simply divide the desired flow rate by the flow rate calculated from the graph to determine the correct Cv. For example, if an air flow of 150 SCFM was found from the graph and the application needs 450 SCFM, choose a valve with a Cv equal to 450/150, or 3.

Liquid Service

Sizing a valve for liquid service is similar to that for gas service, including the required information:

- Upstream pressure (inlet pressure to the valve)
- Pressure differential (or downstream pressure, the outlet pressure of the valve)
- Actual flow through the valve in GPM, or Cv required to yield the desired flow
- The liquid that will be flowing through the valve, and its specific gravity

With these parameters known, refer to chart (3). This chart provides flow (in GPM) for a valve operating on water with a Cv factor of 1.

FLUID COMPATIBILITY

Fluids	Metals							Elastomers and Plastics										
	Aluminum	Brass	Copper	Silver	Stainless Steel			EPDM	FKM	NBR	Nylon	PCTFE	PSF Polysulfone	Ruby	PFPM	CR	PTFE	Noryl
					18-8, 302, 303, 304, 305	316	430F											
Acetic Acid 98%	B	M	M	B	F	S	B	M	M	M	B	B	B	B	B	B	B	B
Acetylene	B	B	B	B	B	S	B	B	M	M	B	B	B	B	B	M	B	B
Acetylene Dry	B	B	M	B	B	S	B	B	M	M	B	B	B	B	M	B	B	B
Air, Liquefied (24°F) (24°F)	B	B	B	B	B	S	B	B	M	M	B	B	B	B	B	B	B	B
Air, Liquefied (24°F) (24°F)	B	B	B	B	B	S	B	B	M	M	B	B	B	B	B	B	B	B
Air, Saturated (130°F) (24°F)	B	B	B	B	B	S	B	B	M	M	B	B	B	B	B	B	B	B
Air, Saturated (130°F) (24°F)	B	B	B	B	B	S	B	B	M	M	B	B	B	B	B	B	B	B
Air, Saturated (24°F) (24°F)	B	B	B	B	B	S	B	B	M	M	B	B	B	B	B	B	B	B
Alcohol, Ethyl (24°F)	T	F	F	B	B	S	B	B	M	M	B	B	B	B	B	B	B	B
Alcohol, Methyl (24°F)	T	F	F	B	B	S	B	B	M	M	B	B	B	B	B	B	B	B
Ammonia Gas, Anhydrous (24°F)	B	M	F	B	B	S	B	B	M	M	B	B	B	B	B	B	B	B
Ammonia	B	B	B	B	B	S	B	B	M	M	B	B	B	B	B	B	B	B
Ammonia, Liquefied	B	B	B	B	B	S	B	B	M	M	B	B	B	B	B	B	B	B
Asphalt	B	B	B	B	B	S	B	B	M	M	B	B	B	B	B	B	B	B
Asphalt, Heavy	B	B	B	B	B	S	B	B	M	M	B	B	B	B	B	B	B	B
Asphalt, Light	B	B	B	B	B	S	B	B	M	M	B	B	B	B	B	B	B	B
Asphalt, Medium	B	B	B	B	B	S	B	B	M	M	B	B	B	B	B	B	B	B
Asphalt, Heavy	B	B	B	B	B	S	B	B	M	M	B	B	B	B	B	B	B	B
Asphalt, Light	B	B	B	B	B	S	B	B	M	M	B	B	B	B	B	B	B	B
Asphalt, Medium	B	B	B	B	B	S	B	B	M	M	B	B	B	B	B	B	B	B
Asphalt, Heavy	B	B	B	B	B	S	B	B	M	M	B	B	B	B	B	B	B	B
Asphalt, Light	B	B	B	B	B	S	B	B	M	M	B	B	B	B	B	B	B	B
Asphalt, Medium	B	B	B	B	B	S	B	B	M	M	B	B	B	B	B	B	B	B
Asphalt, Heavy	B	B	B	B	B	S	B	B	M	M	B	B	B	B	B	B	B	B
Asphalt, Light	B	B	B	B	B	S	B	B	M	M	B	B	B	B	B	B	B	B
Asphalt, Medium	B	B	B	B	B	S	B	B	M	M	B	B	B	B	B	B	B	B
Asphalt, Heavy	B	B	B	B	B	S	B	B	M	M	B	B	B	B	B	B	B	B
Asphalt, Light	B	B	B	B	B	S	B	B	M	M	B	B	B	B	B	B	B	B
Asphalt, Medium	B	B	B	B	B	S	B	B	M	M	B	B	B	B	B	B	B	B
Asphalt, Heavy	B	B	B	B	B	S	B	B	M	M	B	B	B	B	B	B	B	B
Asphalt, Light	B	B	B	B	B	S	B	B	M	M	B	B	B	B	B	B	B	B
Asphalt, Medium	B	B	B	B	B	S	B	B	M	M	B	B	B	B	B	B	B	B
Asphalt, Heavy	B	B	B	B	B	S	B	B	M	M	B	B	B	B	B	B	B	B
Asphalt, Light	B	B	B	B	B	S	B	B	M	M	B	B	B	B	B	B	B	B
Asphalt, Medium	B	B	B	B	B	S	B	B	M	M	B	B	B	B	B	B	B	B
Asphalt, Heavy	B	B	B	B	B	S	B	B	M	M	B	B	B	B	B	B	B	B
Asphalt, Light	B	B	B	B	B	S	B	B	M	M	B	B	B	B	B	B	B	B
Asphalt, Medium	B	B	B	B	B	S	B	B	M	M	B	B	B	B	B	B	B	B
Asphalt, Heavy	B	B	B	B	B	S	B	B	M	M	B	B	B	B	B	B	B	B
Asphalt, Light	B	B	B	B	B	S	B	B	M	M	B	B	B	B	B	B	B	B
Asphalt, Medium	B	B	B	B	B	S	B	B	M	M	B	B	B	B	B	B	B	B
Asphalt, Heavy	B	B	B	B	B	S	B	B	M	M	B	B	B	B	B	B	B	B
Asphalt, Light	B	B	B	B	B	S	B	B	M	M	B	B	B	B	B	B	B	B
Asphalt, Medium	B	B	B	B	B	S	B	B	M	M	B	B	B	B	B	B	B	B
Asphalt, Heavy	B	B	B	B	B	S	B	B	M	M	B	B	B	B	B	B	B	B
Asphalt, Light	B	B	B	B	B	S	B	B	M	M	B	B	B	B	B	B	B	B
Asphalt, Medium	B	B	B	B	B	S	B	B	M	M	B	B	B	B	B	B	B	B
Asphalt, Heavy	B	B	B	B	B	S	B	B	M	M	B	B	B	B	B	B	B	B
Asphalt, Light	B	B	B	B	B	S	B	B	M	M	B	B	B	B	B	B	B	B
Asphalt, Medium	B	B	B	B	B	S	B	B	M	M	B	B	B	B	B	B	B	B
Asphalt, Heavy	B	B	B	B	B	S	B	B	M	M	B	B	B	B	B	B	B	B
Asphalt, Light	B	B	B	B	B	S	B	B	M	M	B	B	B	B	B	B	B	B
Asphalt, Medium	B	B	B	B	B	S	B	B	M	M	B	B	B	B	B	B	B	B
Asphalt, Heavy	B	B	B	B	B	S	B	B	M	M	B	B	B	B	B	B	B	B
Asphalt, Light	B	B	B	B	B	S	B	B	M	M	B	B	B	B	B	B	B	B
Asphalt, Medium	B	B	B	B	B	S	B	B	M	M	B	B	B	B	B	B	B	B
Asphalt, Heavy	B	B	B	B	B	S	B	B	M	M	B	B	B	B	B	B	B	B
Asphalt, Light	B	B	B	B	B	S	B	B	M	M	B	B	B	B	B	B	B	B
Asphalt, Medium	B	B	B	B	B	S	B	B	M	M	B	B	B	B	B	B	B	B
Asphalt, Heavy	B	B	B	B	B	S	B	B	M	M	B	B	B	B	B	B	B	B
Asphalt, Light	B	B	B	B	B	S	B	B	M	M	B	B	B	B	B	B	B	B
Asphalt, Medium	B	B	B	B	B	S	B	B	M	M	B	B	B	B	B	B	B	B
Asphalt, Heavy	B	B	B	B	B	S	B	B	M	M	B	B	B	B	B	B	B	B
Asphalt, Light	B	B	B	B	B	S	B	B	M	M	B	B	B	B	B	B	B	B
Asphalt, Medium	B	B	B	B	B	S	B	B	M	M	B	B	B	B	B	B	B	B
Asphalt, Heavy	B	B	B	B	B	S	B	B	M	M	B	B	B	B	B	B	B	B
Asphalt, Light	B	B	B	B	B	S	B	B	M	M	B	B	B	B	B	B	B	B
Asphalt, Medium	B	B	B	B	B	S	B	B	M	M	B	B	B	B	B	B	B	B
Asphalt, Heavy	B	B	B	B	B	S	B	B	M	M	B	B	B	B	B	B	B	B
Asphalt, Light	B	B	B	B	B	S	B	B	M	M	B	B	B	B	B	B	B	B
Asphalt, Medium	B	B	B	B	B	S	B	B	M	M	B	B	B	B	B	B	B	B
Asphalt, Heavy	B	B	B	B	B	S	B	B	M	M	B	B	B	B	B	B	B	B
Asphalt, Light	B	B	B	B	B	S	B	B	M	M	B	B	B	B	B	B	B	B
Asphalt, Medium	B	B	B	B	B	S	B	B	M	M	B	B	B	B	B	B	B	B
Asphalt, Heavy	B	B	B	B	B	S	B	B	M	M	B	B	B	B	B	B	B	B
Asphalt, Light	B	B	B	B	B	S	B	B	M	M	B	B	B	B	B	B	B	B
Asphalt, Medium	B	B	B	B	B	S	B	B	M	M	B	B	B	B	B	B	B	B
Asphalt, Heavy	B	B	B	B	B	S	B	B	M	M	B	B	B	B	B	B	B	B
Asphalt, Light	B	B	B	B	B	S	B	B	M	M	B	B	B	B	B	B	B	B
Asphalt, Medium	B	B	B	B	B	S	B	B	M	M	B	B	B	B	B	B	B	B
Asphalt, Heavy	B	B	B	B	B	S	B	B	M	M	B	B	B	B	B	B	B	B
Asphalt, Light	B	B	B	B	B	S	B	B	M	M	B	B	B	B	B	B	B	B
Asphalt, Medium	B	B	B	B	B	S	B	B	M	M	B	B	B	B	B	B	B	B
Asphalt, Heavy	B	B	B	B	B	S	B	B	M	M	B	B	B	B	B	B	B	B
Asphalt, Light	B	B	B	B	B	S	B	B	M	M	B	B	B	B	B	B	B	B
Asphalt, Medium	B	B	B	B	B	S	B	B	M	M	B	B	B	B	B	B	B	B
Asphalt, Heavy	B	B	B	B	B	S	B	B	M	M	B	B	B	B	B	B	B	B
Asphalt, Light	B	B	B	B	B	S	B	B	M	M	B	B	B	B	B	B	B	B
Asphalt, Medium	B	B	B	B	B	S	B	B	M	M	B	B	B	B	B	B	B	B
Asphalt, Heavy	B	B	B	B	B	S	B	B	M	M	B	B	B	B	B	B	B	B
Asphalt, Light	B	B	B	B	B	S	B	B	M	M	B	B	B	B	B	B	B	B
Asphalt, Medium	B	B	B	B	B	S	B	B	M	M	B	B	B	B	B	B	B	B
Asphalt, Heavy	B	B	B	B	B	S	B	B	M	M	B	B	B	B	B	B	B	B
Asphalt, Light	B	B	B	B	B	S	B	B	M	M	B	B	B	B	B	B	B	B
Asphalt, Medium	B	B	B	B	B	S	B	B	M	M	B	B	B	B	B	B	B	B
Asphalt, Heavy	B	B	B	B	B	S	B	B	M	M	B	B	B	B	B	B	B	B
Asphalt, Light	B	B	B	B	B	S	B	B	M	M	B	B	B	B	B	B	B	B
Asphalt, Medium	B	B	B	B	B	S	B	B	M	M	B	B	B	B	B	B	B	B
Asphalt, Heavy	B	B	B	B	B	S	B	B	M	M	B	B	B	B	B	B	B	B
Asphalt, Light	B	B	B	B	B	S	B	B	M	M	B	B	B	B	B	B	B	B
Asphalt, Medium	B	B	B	B	B	S	B	B	M	M	B	B	B	B	B	B	B	B
Asphalt, Heavy	B	B	B	B	B	S	B	B	M	M	B	B	B	B	B	B	B	B
Asphalt, Light	B	B	B	B	B	S	B	B	M	M	B	B	B	B	B	B	B	B
Asphalt, Medium	B	B	B	B	B	S	B	B	M	M	B	B	B	B	B	B	B	B
Asphalt, Heavy	B	B	B	B	B	S	B	B	M	M	B	B	B	B	B	B	B	B
Asphalt, Light	B	B	B	B	B	S	B	B	M	M	B	B	B	B	B	B	B	B
Asphalt, Medium	B	B	B	B	B	S	B	B	M	M	B	B	B	B	B	B	B	B
Asphalt, Heavy	B	B	B	B	B	S	B	B	M	M	B	B						

Unit Conversion Charts

Fractional Conversions		
mm	inches	decimal inches
0.79	1/32	0.031
1.59	1/16	0.063
2.38	3/32	0.094
3.18	1/8	0.125
3.97	5/32	0.156
4.76	3/16	0.188
5.56	7/32	0.219
6.35	1/4	.0250
7.14	9/32	0.281
7.94	5/16	0.313
8.73	11/32	0.344
9.53	3/8	0.375
10.3	13/32	0.406
11.1	7/16	0.438
11.9	15/32	0.469
12.7	1/2	0.500
13.5	17/32	0.531
14.3	9/16	0.563
15.1	19/32	0.594
15.9	5/8	0.625
16.7	21/32	0.656
17.5	11/16	0.688
18.3	23/32	0.719
19.1	3/4	0.750
19.8	25/32	0.781
20.6	13/16	0.813
21.4	27/32	0.844
22.2	7/8	0.875
23.0	29/32	0.906
23.8	15/16	0.938
24.6	31/32	0.969
25.4	1	1.000

Measures

1 inch = 25.4mm
 1 inch = 2.54cm
 1 U.S. gal = 3.785 liters
 1 Imperial gallon = 4.546 liters

Pressure

1 psi = 0.0703 Kg/square cm
 1 psi = 27.73 inches water (@60/F)
 1 psi = 2.036 inches of mercury (@32/F)
 1 psi = 51.7 mm of mercury (@32/F)
 1 psi = 0.0689 bar

Vacuum

1 torr = 1 mm mercury
 1 micron = 0.001 torr

Volumetric Flow Rate

1 Cv = 14.28 Kv
 1 gpm = 3.785 liters/min (U.S. gallon)
 1 cfm = 28.317 liters/min
 1 liter/min = 0.0353 cfm

Temperature

Degrees C = (Degrees F-32) (5/9)
 Degrees F = (Degrees C) (9/5) + 32

Torque

1 in lb. = 0.113 Nm
 1 in lb. = 1.15 cm Kg

7000 SERIES TECHNICAL INFORMATION

The Skinner 7000 Series Numbering System

The Skinner 7000 Series numbering system was designed with our customers in mind. It is a significant numbering system that allows every user an easy method to select, identify and understand the product being purchased. In its significance, this numbering system provides a complete description of every valve, and makes specification, cross referencing, and substitution work a simple task.

Provided below is a complete set of numbering

system codes. The codes apply to three major valve components: the pressure vessel, enclosure and coil.

A complete valve number will always be 20 digits in length.

7000 Series Numbering System—Digit Assignments

- Pressure Vessel 1-12
- Enclosure 13-14
- Coil and Voltage 15-20

A COMPLETE VALVE ASSEMBLY EXAMPLE

Pressure Vessel	Enclosure	Coil	Voltage Code
71215SN1VN00	N0	C111	P3

DESCRIPTION OF SIGNIFICANT DIGITS

Digit	Title of Code	Description of Code
1	7	7000 Series designation
2	Actuation	Type of operator design used to open/close the valve
3	Functional Type	Conventional description of flow capabilities (number of ways)
4	Flow Pattern	De-energized flow position/condition, e.g. normally closed
5	Family	A designation associated with body geometry
6	Body Material	Material from which the body is constructed
7	Process Connection	The type of threading or connection to user media
8	Port Size	Size of the process connection
9	Orifice Size	Size or Cv factor of main fluid passage
10	Seal Material	Material of main orifice seal
11,12	Mechanical Options	Options to the pressure vessel
13	Enclosure	Type of housing surrounding the coil
14	Enclosure Options	Options to the housing and /or label
15	Coil Termination	Type of electrical connection
16	Coil Wattage/Class	Power level and temperature rating of coil
17,18	Electrical Options	Optional coil and/or termination configuration
19,20	Voltage Code	A two digit code denoting voltage and frequency

PRESSURE VESSEL NUMBERING 2-WAY VALVES

For reference only. Consult catalog listings for available combinations.

1	2	3	4	5	6	7	8	9	10	11 & 12		
	Actuation	Functional Type	Flow Pattern	Family*	Body Material	Threading/ Process Connection	Pipe Size (NPT)	Orifice Code#	Seals/+ Elastomers	Mech. Options		
7	1 Direct Acting 2 Direct Lift	2 Two-Way	1 Normally Closed	1	A Aluminum	A SAE	1 1/8"	A	C CR	00	No Option	
			2 Normally Open	2	B Brass	E Male NPT	2 1/4"	B	E EPDM	A2	Silver Shading Ring	
	3 Pilot Operated Internal Pilot Supply		3 Multi/Dual purpose	4	L Noryl	F Flange	3 3/8"	C	F PCTFE	C0	4-Step Variable Closing	
			4 Pilot Operated External Pilot Supply	9 Normally Open pressure in the body, pressure out the sleeve	5	R 316 SS	G BSP-Parallel	4 1/2"	D	K PPFM	J1	Exhaust Adaptor Nut
	5 Remote Pressure Operated		6 Manual/Mech. Operated	6	S 430F SS	R BSP-Taper	5 3/4"	E	L Nylon	M0	Manual Override	
	8 Teflon			8	T Teflon	J Bib Fitting	6 1"	F	M Metal	MC	Manual Override w/Var. Closing	
				9 303 SS	9	V 303 SS	N NPT(Female Nat'l Pipe thread)	7 1 1/4"	G	N NBR	M5	Manual Override w/Exhaust Adaptor
	F Barbed Fitting			8	F		T Barbed Fitting	8 1 1/2"	H	R Ruby	R1	Mainstream Metering
				G				9 2"	J	T PTFE		
	H								K	U PTFE		
	K							L	V FKM			
								M				SO WO NO
						N						
						P						
						Q						
						R						
						S						
						T						
						U						
						V						
						0 thru 9						

Note: These tables are provided to interpret product specifications. It should not be used to create a valve number without reference to the catalog listings or consultation with Fluid Control Division personnel.

* The family designator is assigned to organize products by physical similarity.

Orifice codes relate to a range of Cv factors and sizes. They are listed in ascending order.

+ Reference Seal Material Designations, page 117.

PRESSURE VESSEL NUMBERING 3- AND 4-WAY VALVES

For reference only. Consult catalog listings for available combinations.

1	2	3	4	5	6	7	8	9	10	11 & 12		
	Actuation	Functional Type	Flow Pattern	Family*	Body Material	Threading/ Process Connection	Pipe Size (NPT)	Orifice Code#	Seals/+ Elastomers	Mech. Options		
7	1 Direct Acting 2 Direct Lift	3 Three-Way	3-Way Valves 1 Normally Closed 2 Normally Open pressure in/out of body 3 Multi/Dual Purpose 4 Diverting 5 Normally Open pressure in the sleeve, pressure out the body 4-Way Valves 1 2-position, single operator 2 3-position, dual operator center closed 3 3-position, dual operator center open 4 3-position, dual operator center open 6 2-position, dual operator bi-stable 7 2-position, dual operator bi-stable, with latching	1	A Aluminum	A SAE	1 1/8"	A	C CR	00	No Option	
		4 Four-Way		2	B Brass	E Male NPT	2 1/4"	B	E EPDM	A2	Silver Shading Ring	
	3 Pilot Operated Int. Pilot Supply	3		L Noryl	F Flange	3 3/8"	C	F PCTFE				
		4 Pilot Operated Ext. Pilot Supply		4	M Zinc Die Cast	G BSP-Parallel	4 1/2"	D	K PPFM	CB	Cylinder "B" normally open to pressure inlet	
	5 Remote Pressure operated	6 Manual/Mech. Operated		8	R 316 SS	R BSP-Taper	5 3/4"	E	L Nylon	C0	4-Step Variable Closing	
	8 Teflon			9	S 430F SS	J Bib Fitting	6 1"	F	M Metal	J0	Pilot Exhaust Return Pipe	
				8	T Teflon	N NPT (Female National Pipe Thread)	7 1 1/4"	G	N NBR	J1	Exhaust Adaptor Nut	
	9 303 SS			9	V 303 SS	S Subbase Mounted	8 1 1/2"	H	R Ruby	M0	Manual Override	
				E		T Barbed Fitting	9 2"	J	T PTFE	MC	Manual Override w/Var. Closing	
	F							K	U PTFE	MJ	Manual Override w/Exhaust Return Pipe	
	G						L	V FKM	MR	Manual Override w/Main Stream Metering		
	H							M		M5	Manual Override w/Exhaust Adaptor	
K						N						
L						P						
T						Q						
						R					SO WO NO	Steam Service Rated Anti-Water Hammer (fixed) Cleaned for oxygen service
						S						
						T						
						U						
						V						
						0 thru 9						

ENCLOSURE, COIL AND VOLTAGE NUMBERING 2-, 3- AND 4-WAY VALVES

13 & 14 Enclosure Type		15 & 16 Coil Construction and Type		17 & 18 Terminations and Option Codes		19 & 20 Voltage	
A0	7/8" Knockout	C1	Integrated Coils 1/2" NPT Conduit, 10 Watt Class F, NEMA 4X	00	Standard DIN, Screw, Tab Coils (no leads)	B2	24/60
B0	1/2" Conduit	C2	1/2" NPT Conduit, 10 Watt Class H, NEMA 4X	11	Class F Coils with 18" leads	C1	12VDC
F0	Yoke	C3	1/2" NPT Conduit, 22 Watt Class H, NEMA 4X	22	Class H Coils with 18" leads	C2	24VDC
G0	Water Tight	D1	DIN, 10 Watt Class F	GL	C1,C2,C3 & H1,H2, H3 Coils with Ground lead	C4	48VDC
J0	Junction Box	D2	DIN, 10 Watt Class H	D1	All DIN Coils with Cable Gland Connector	C6	120VDC
M1	Magnelatch	D3	DIN, 22 Watt Class H	D2	All DIN Coils with 1/2" Conduit Connector	P0*	24,50/60
M2	Magnelatch Grommet	H1	1/2" NPT Conduit, 10 Watt Class F, NEMA 7, 9	D4	D1,D2,D4 coils for timer assembly with fixed-off and adjustable on-time	P3	110/50-120/60
NO	Nut and Washer	H2	1/2" NPT Conduit, 10 Watt Class H, NEMA 7, 9	DB	All DIN Coils with Terminal Box	Q3	220/50-240/60
		H3	1/2" NPT Conduit, 22 Watt Class H, NEMA 7, 9	TB	S1,S2,S3 Coils with Terminal Box	Q8	440/50-480/6
		L1	18" leads, 10 Watt Class F	S1	Hazardous stainless steel yoke with 18" leads and ground lead	2K	208/60
		L2	18" leads, 10 Watt Class H			2W*	110-120,50/60
		L3	18" leads, 22 Watt Class H				
		S1	Screw Terminal, 10 Watt Class F				
		S2	Screw Terminal, 10 Watt Class H				
		S3	Screw Terminal, 22 Watt Class H				
		T1	1/4" Tab Terminal, 10 Watt Class F				
			Conventional Coils				
		J1	18" leads, 10 Watt Class F				
		J2	18" leads, 10 Watt Class H				
		J3	18" leads, 22 Watt Class H				
			Specialty Coils				
		F6	Fluxtron 4-wire, 1 Watt molded				
		J6	Fluxtron 2-wire, 1 Watt molded				
		J0	Magnelatch 2-wire DC only				
		G0	Magnelatch 3-wire AC/DC (DC pulse)				









* Fluxtron only

ELECTRICAL ENCLOSURE OPTIONS

A coil enclosure is needed to complete the magnetic flux path of conventional molded coils and specialty coils. The enclosure can also serve to protect the coil and provide a means to accommodate the electrical connection. This section describes the most common electrical enclosure options available.

7000 Series Enclosure Options

7000 Series integrated coils incorporate these features into a one-piece assembly which requires only a nut and washer (enclosure code NO) to fasten to the pressure vessel. The 7000 Series conventional enclosure selection is provided to complement the integrated coil offering providing flexibility in product type and installation.

Coil Picture	Enclosure Code	Description	Applicable Coils
	A0	Standard Connection, 7/8" exit to accommodate strain relief, adapter or fittings for lead wires, NEMA Type 2	J111, J222, J322, F611, J611
	B0	1/2" Conduit Connection for attachment of conduit, 1/2" NPT fittings or BX cable, NEMA Type 2	F611, J611
	F0	Yoke for use where open enclosure is suitable	F611, J611
	G0	Watertight, 1/2" conduit hub accommodating 1/2" NPT fittings or BX cable, NEMA Type 4X	F611, J611
	J0	Splice box, 7/8" exit allowing for internal splice, NEMA Type 2	J111, J222, J322, F611, J611
	M1	Magnelatch, 1/2" conduit hub for attachment of conduit, 1/2" NPT fittings or BX cable, NEMA Type 2	G011, J011
	M2	Magnelatch, leaded with grommet connection, NEMA Type 2	G011, J011
	NO	Nut and Washer	All Integrated Coils

7000 Series Electrical Options

Various electrical accessories are available with 7000 Series integrated coils. These accessories are available as individual pieces; see chart. To order a coil with the accessory attached, write the electrical option code in place of the last two digits of the coil code.

Coil Option Picture	Accessory Part #	Coil Option Code	Description	Coil Types	Coil Codes
	N/A	GL	Ground Lead 18"	Conduit Terminated	C1GL, C2GL, C3GL H1GL, H2GL, H3GL
	ELECD1	D1*	Cable Gland DIN Plug	DIN	D1D1, D2D1, D3D1
	ELECD2	D2*	1/2" Conduit DIN Plug	DIN	D1D2, D2D2, D3D2
	ELECD4	D4#	Timer, 12-48VDC 24-120, 50/60 Hz	DIN, AC & DC	D1D4, D2D4, D3D4
	ELECDB	DB^	Terminal Box	DIN	D1DB, D2DB, D3DB
	ELECTB	TB^	Terminal Box	Screw Terminal	S1TB, S2TB, S3TB

* The plug comes complete with gasket
The timer has a fixed "off" time of 12 minutes and an adjustable "on" time which ranges from 1 second to 2 minutes. The timer comes complete with 24" 3-wire cable. Available on Timer Drain Valves 7321KBY61640, 7321KBY63200, and 7321KBY6320A on page 25.

^ Meets NEMA 4, 4X when connected to a Screw Terminal or DIN Coil, as applicable. It is provided with a 1/2" NPT conduit thread and ground screw.

7000 Series Mechanical Options

Solenoid valves at times requires a variety of different mechanical options to meet the specific needs of a given application.

Skinner has the ability to produce wide varieties and combinations of mechanical options. Listed are only a few of the common options we provide. If the option (or set of options) you need is not listed, please contact a company representative for assistance.

Available options are denoted by the valve family to which they pertain. The 7000 Series family designator is position 5 of the pressure vessel number. To order the other listed mechanical options:

- 1) Select the base pressure vessel number. It must have "00" in the last two digits.
- 2) Confirm compatibility of the option with the Mechanical Options Table.
- 3) Write the mechanical option code in place of the last two digits of the pressure vessel number. For example, a 71215SN1GN00 with a manual override (M0) becomes 71215SN1GNM0.

Code	Mechanical Options Descriptions	7000 Series Valve Families (pressure vessel 5th digit)												
		1	2	3	4	5	6	8	9	E	F	G	K	T
A2	Silver Shading Ring			X		X	X	X						
J0	Pilot Exhaust Return Pipe		X											
J1	Exhaust Adapter Nut		X	X	X			X	X	X		X		
M0#	Manual Override		X		X			X					X	
M5	M0 w/ Exhaust Adapter Nut		X		X			X						
MJ	M0 w/ Pilot Exhaust Return Pipe		X											
R1**	Main Stream Metering			X	X									
S0*	Steam Service Rated							X			X	X		

Note: Not all options designated in this table are applicable to every valve within the valve family. Some exceptions are noted below. For details on specific valve option compatibility, consult the factory.

Not available on the following valve series: 71225, 71295, 7122K, 72218, 72228, 7221G, 7322G, and 73222. Not

available on 3/8" NPT or 1/2" NPT "5" and "K" family valves.

** Not available on 3/8" NPT valves.

Agency Approval Note: Valves listed as Safety Shutoff Valves (SS in catalog listings) are not permitted with Manual Override and/or Bypass Options (M0, MC, M5, R1, above). Valves with these options are considered General Purpose Valves.

Agency Approvals

Most 7000 series solenoid valves are approved by Underwriter's Laboratories (UL) and certified by the Canadian Standards Association (CSA). The table summarizes the specific approvals obtained, which are dependent upon the combination of approved pressure vessels, coils and enclosures for both ordinary and hazardous locations.

Agency Approved Solenoid Valve Combinations

Enclosure Code	Coil* Type/Option	Metallic Bodied Pressure Vessels (Aluminum, Brass, Stainless Steel, Zinc)		Plastic Bodied Pressure Vessels** (Noryl, Teflon) All Porting Types			
		NPT ported	FLG mounted				
NO	C111, C222, C322	UL Listed					
NO	C1GL, C2GL, C3GL						
NO	D1DB, D2DB, D3DB						
AO,BO,GO,JO	F611, J611						
AO,JO	J111, J222, J322						
NO	H111, H222, H322						
NO	H1GL, H2GL, H3GL						
NO	S1TB, S2TB, S3TB						
NO	D100, D1D1, D1D2				UL Component Recognized		
NO	D200, D2D1, D2D2						
NO	D300, D3D1, D3D2						
FO	F611, J611						
NO	L111, L222, L322						
NO	S100, S200, S300						
NO	T100						

UL approved valves are also CSA certified. Consult Fluid Control Division.

* Coil voltage must also be approved. See pages 12 and 13.
 ** Pressure vessels must be approved as Safety Shutoff (SS) or General Purpose (GP) valves. See catalog sections.

Types of Protection of Solenoids for Hazardous Environments

Standards are established by the European Committee for Electro-Technical Standards (CENELEC). Degrees of Protection of electrical parts and operating temperatures are defined by various European standards.

The following charts show the Degree of Protection for the selected coils along with the maximum surface temperatures for each temperature code classification.

Protection Class	Degree of Protection
IP-65	Protection against ingress of dust (dust proof) Protection against contact with internal parts Protection against a water jet from a nozzle from all directions
IP-67	Protection against ingress of dust (dust proof) Protection against contact with internal parts Protection against water when the equipment is immersed in water under specific pressure and time conditions

Temperature Classification	Maximum Allowable Surface Temperature	
	°C	°F
T1	450	842
T2	300	572
T3	200	392
T4	135	257
T5	100	212
T6	85	185

Response Time

The response time of a solenoid valve depends on many factors such as voltage, frequency, pressure, media, temperature (including coil) and the type of valve. Variations in these factors can have a significant effect on the response time. The following tabulation lists the approximate response times for several different types of valves. The times given are for the valves to go from closed position to open or from open position to closed.

Valve Type	Response Time (milliseconds)
Direct Acting Valves	4-15
Small Pilot Operated Piston Valves	30-90
Large Pilot Operated Piston Valves	100-150
Small Pilot Operated Diaphragm Valves	30-60
Large Pilot Operated Diaphragm Valves	60-160
Direct Lift Diaphragm Valves	30-60

Operating Speed (Cycle Rates)

Operating speed is defined as the maximum number of cycles (On/Off) per minute that a solenoid valve is capable of completing. It is dependent upon the response time characteristics of the valve. Many of our small, short stroke, direct acting valves are capable of operating at rates over 2,000 cycles per minute. However, for normal operation lower cycle rates as shown are usually recommended.

Valve Type	Up To (cycles/min)
Direct Acting Valves	600
Small Pilot Operated Piston Valves	400
Large Pilot Operated Piston Valves	150
Small Pilot Operated Diaphragm Valves	300
Large Pilot Operated Diaphragm Valves	200
Direct Lift Diaphragm Valves	200

Vacuum

While many of our solenoid valves with elastomeric seals listed in this catalog can be used on vacuum, the standard 100% production leakage test does not ascertain that the valves are sufficiently tight for severe vacuum applications. We do, however, design, produce, and test many vacuum valves to meet specific customer requirements. Therefore, we invite you to consult us for your vacuum valve applications.

Fluid Temperature Limitations

32°F Minimum Fluid Temperature if moisture is present. Otherwise minus 40°F for direct acting valves with NBR seals, minus 10°F with FKM seals (minus 10°F for "4" family valves). For exceptions, consult the factory.

7000 Series Solenoid Valve Seal Materials

7000 Series solenoid valves are constructed with the finest elastomeric and plastic seal materials available to ensure dependable bubbletight operation and long life. Most of the valves in the catalog utilize a single seal material whether a plunger seal or a flange seal. However, many valve designs require a variety of different sealing materials.

The 7000 Series numbering system delineates the tenth digit for description of the main orifice seal—the seal that actually prevents flow through the valve. For direct acting valves this represents the

plunger seal and for pilot operated valves this represents the diaphragm. Since every seat material cannot be specified in the significant valve number, the following table can be used to determine the additional seat materials used.

Example: Valve No. 71215SN1EF00

Tenth digit F = Kel F seal material. Since this is a direct acting valve, the plunger seal is PCTFE. From the table, we see that when a plunger seal is PCTFE, the flange seal is FKM. (this valve has no diaphragm)

Example: Valve No. 73218BN3TE00

Tenth digit E = EPDM seal material. Since this is

a pilot operated valve, the diaphragm is EPDM. From the table, we see that when the diaphragm is EPDM, the plunger and flange seal is EPDM.

Standard Seal Material Combinations

Plunger Seal	Flange Seal	Piston or Diaphragm Seal
NBR	NBR	NBR
FKM	FKM	FKM
Ruby	FKM	FKM
PCTFE	FKM	FKM
PFFM	PTFE	PTFE
EPDM	EPDM	EPDM
PTFE	PTFE	PTFE
CR	CR	CR

Note: See Seal Material Designation Chart page 117.

Non-Standard Seal Material Combinations

There are some exceptions to the above standard. The following valve types do not conform to the table of standard seal material combinations and are therefore specified in this table. Non-metallic orifice materials are specified where applicable.

2-Way Valves

Catalog Number	Orifice (if non-metallic)	Plunger Seal	Flange Seal	Diaphragm Seal	Piston Seal	Other Seal
71216SN1BL00	Nylon	-	NBR	-	-	-
71216SN2BL00						
71216SN1GL00						
71216SN2GL00						
71216SN1FU00	Rulon	-	NBR	-	-	-
71216SN2FU00						
71216SN1JT00	PTFE	-	NBR	-	-	-
71216SN2JT00						
72228BN3TES0	-	FKM	EPDM	EPDM	-	EPDM, FKM
72228BN4UES0						
72228BN5VES0						
73216BN2MT00	Nylon	-	NBR	-	PTFE	NBR
73216SN2MT00	Polysulfone	-	NBR	-	PTFE	NBR
73222BN2MN00	-	FKM	NBR	-	NBR	NBR
73222SN2MN00						

NOTE: There may exist especially exacting application requirements which would necessitate a more detailed description of the various components and materials employed in the construction of Skinner solenoid valves. In such cases, contact the factory so that we may provide you with more detailed information.

Seal Material Designations

ASTM Designation	Commercial Designations and/or Trade Names	7000 Series Seal Designation
NBR	Buna-N, Nitrile	N
EPDM	Ethylene Propylene	E
FKM	Fluorinated Hydrocarbon, Viton®	V
PCTFE	Kel-F	F
PTFE	Teflon®, Rulon®AR	T
PFFM	Kalrez	K
CR	Neoprene	C

Viton® and Teflon® are Dupont Co. trademarks.
Rulon®AR is a Furon—Advanced Polymers Division trademark

3- and 4-Way Valves

Catalog Number	Orifice (if non-metallic)	Plunger Seal	Flange Seal	Diaphragm Seal	Piston Seal	Other Seal
7131EBN2LN00	FKM	-	-	-	NBR	NBR
7131FBF4LV00	FKM	-	-	-	-	FKM
7133FBF4LV00						
7341LAN1HN00	FKM	-	-	-	NBR	NBR
7341LMN2NN00	FKM	-	-	-	NBR	NBR

NOTE: There may exist especially exacting application requirements which would necessitate a more detailed description of the various components and materials employed in the construction of Skinner solenoid valves. In such cases, contact the factory so that we may provide you with more detailed information.

Integrated Coils and Terminal Box Dimensions

The valve construction reference drawings provide outline dimensions for all pressure vessels contained in this catalog. They are shown with the 1/2" conduit style integrated coil as standard. The individual coil drawings on this page provide dimensions for the other 7000 Series integrated coils. To apply these coil dimensions to any of the standard valve construction references, a datum line (cL) has been included which corresponds to the conduit hub centerline dimension of the 1/2" conduit style integrated coil.

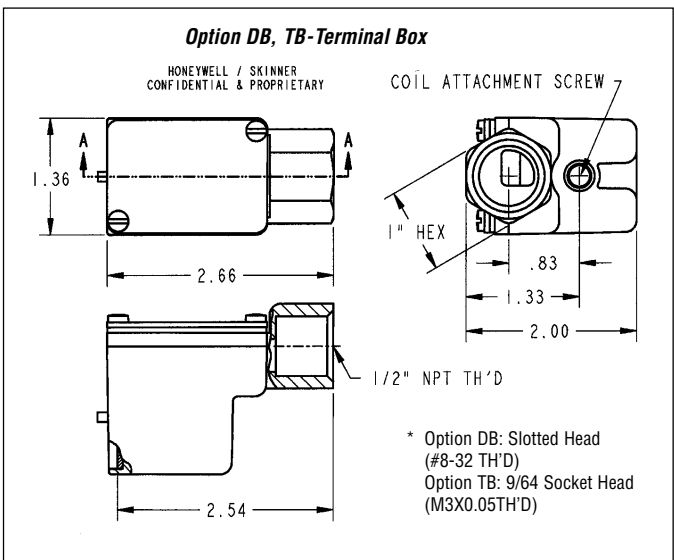
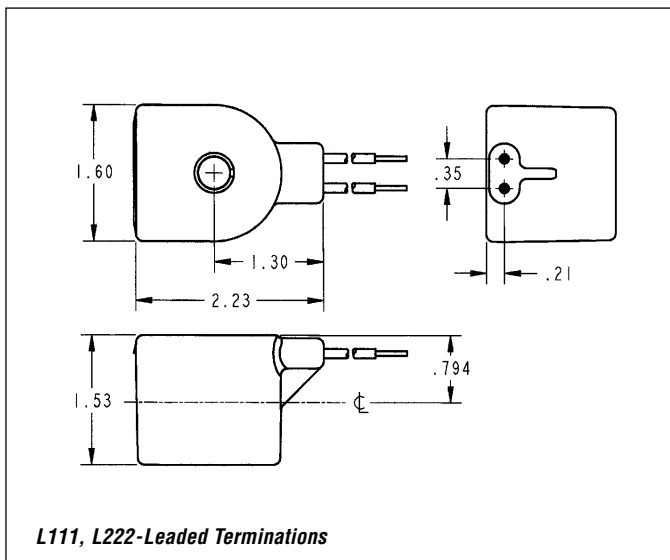
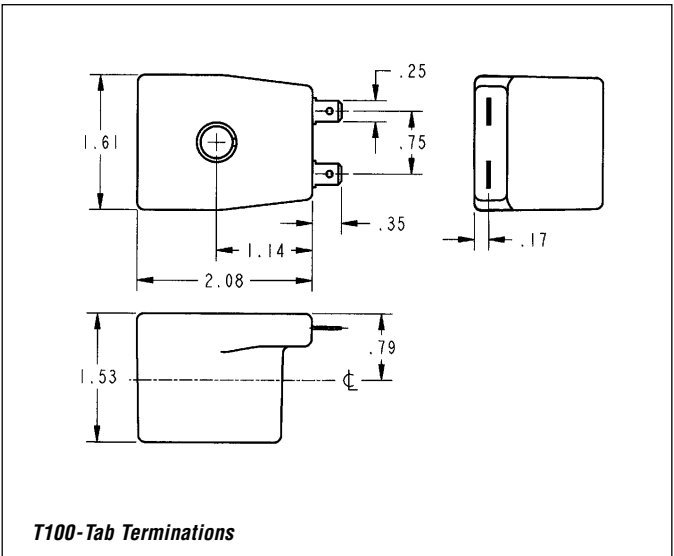
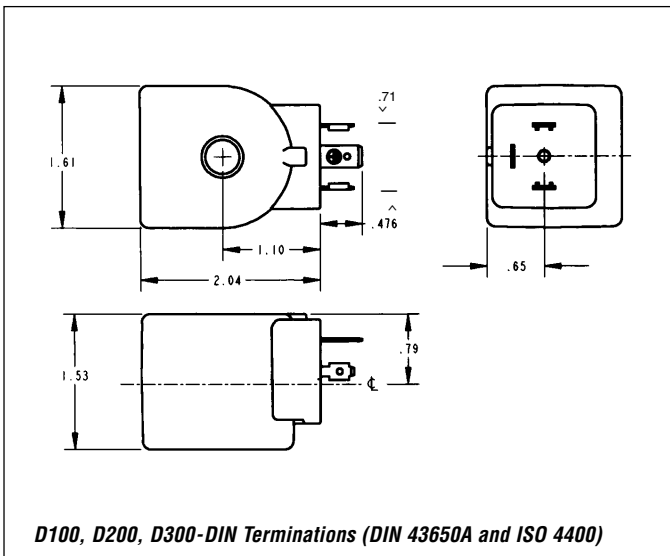
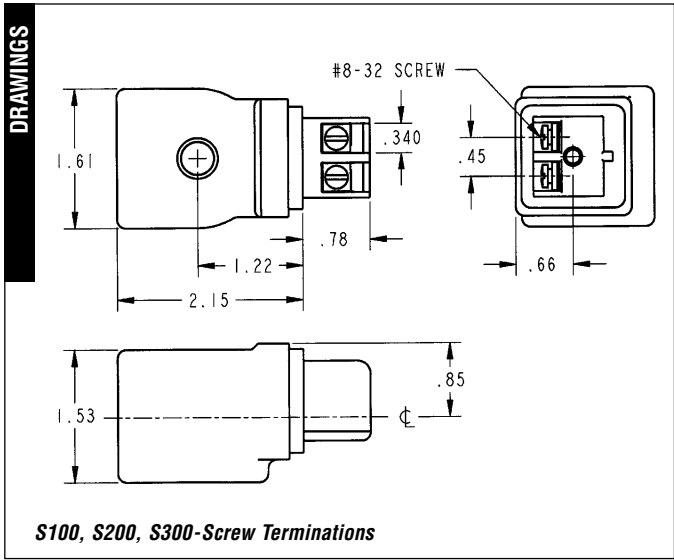

All dimensions in inches.

3000 SERIES TECHNICAL INFORMATION

3000 Series Numbering System Designators

Pressure	1	Series Designation	3	3000 Series	
Vessel	2	Operations	1	Direct Acting, 6 Watt	
			9	Direct Acting, 3 Watt	
	3	Ways (Functional Type)	2	Two-Way	
			3	Three-Way	
	4	Flow Pattern	1	Normally Closed	
			3	Multipurpose	
			8	Directional	
			9	Normally Open, Ported Sleeve	
	5	Family	B	B	
	6	Body Material	B	Brass	
			J	Operator (No Body)	
			S	303 Stainless Steel	
	7	Process Connection	A	Male Straight Thread	
			N	Female National Pipe Thread	
	8	Pipe Size	1	1/8"	
			6	5/16-24 UNF	
			7	3/4-32 UNF	
	9	Orifice	A	1/32"	
			E	3/64"	
			G	1/16"	
			J	5/64"	
			L	3/32"	
			N	1/8"	
			Q	5/32"	
	10	Seal Material	E	EPDM	
			N	NBR	
			V	FKM	
	11	Mechanical Option	00	None	
			AD	1/8" NPT Sleeve Adapter	
			C#	Aluminum, Female 1/8" NPT, 2, 3, or 4 Station Cavity Manifold Block	
			HT	Helium Leak Tested	
			N0	Cleaned for Oxygen Service	
Housing	13	Housing	BB	1/2" Conduit	
			14	N0	No Housing (Integrated Coil)
				RR	Grommet
				YY	Yoke
Coil	15	Coil Designation	M1S1	Integrated Molded, 1/4" Tab, 6W*, Class B	
			MC11	Integrated Class F, 1/2" Conduit 18" Leads, 6W, NEMA 4X	
			MH11	Integrated Class F, 1/2" Conduit 18" Leads, 6W, NEMA 4X, 7, 9	
			M3J5	Integrated Molded, 12" Leads, 6W, Class B	
			M4S1	Integrated Molded, 1/4" Tab, 3W, Class B	
			M6J5	Integrated Molded, 12" Leads, 3W, Class B	
			T1J1	Taped 12" Leads, 6W, Class B	
T3J1	Taped 12" Leads, 3W, Class B				
	19	Voltage Code	P0	24/50-60 Hz AC	
			P3	110/50 Hz, 120/60 Hz AC	
			Q3	220/50 Hz, 240/60 Hz AC	
			C1	12 VDC	
			C2	24 VDC	
	20				





* For all 6 watt Coils, actual wattage for 24/60 Volts is 7.5.

Electrical Enclosure Options

A coil enclosure is needed to complete the magnetic flux path of conventional molded coils and specialty coils. The enclosure can also serve to protect the coil and provide a means to accommodate the electrical connection. This section describes the most common electrical enclosure options available.

3000 Series Enclosure Options

3000 Series integrated coils are a one-piece assembly which requires only a nut and washer (enclosure code NO) to fasten to the pressure vessel. The 3000 Series conventional enclosure selection complements the integrated coil offering providing flexibility in product type and installation.

Coil Picture	Enclosure Code	Description	Applicable Coils
	RR	Grommet Enclosure	T1J1, T3J1
	BB	1/2" Conduit Connection	T1J1, T3J1
	YY	Yoke. For use where open enclosure is suitable	T1J1, T3J1
	NO	Nut for Integrated Molded coils	M1S1, M4S1 M3J5, M6J5
	NO	Nut and Washer for 1/2" Conduit NEMA coils	MC11, HC11

3000 Series Repair Kits/ Accessories

Repair kits are available for all Skinner 3000 Series valves. These kits include a new plunger assembly and plunger return spring. Specify the kit you need by the part number listed, which corresponds to the type of valve and seal material to be rebuilt.

Flow Pattern	NBR	EPDM	FKM
2-Way Normally Closed	3K3121N	3K3121E	3K3121V
2-Way Normally Open	3K3129N	3K3129E	3K3129V
3-Way Normally Closed	3K3131N	3K3131E	3K3131V
3-Way Normally Open	3K3139N	3K3139E	3K3139V
3-Way Multipurpose	3K3133N	3K3133E	3K3133V
3-Way Directional Control	3K3138N	3K3138E	3K3138V

Universal Mounting Bracket – B19-006

SS Adaptor with Gasket = 300-22-004

A, B, C, MB AND V9 SERIES INFORMATION

Coils

To determine the approximate Holding or Inrush Current for AC voltages including 24/60, 120/60, 240/60 and 480/60 volts in amperes, divide the voltage into the VA rating indicated in the AC Power

Consumption tables. DC valves have no inrush current. The current rating in amperes for DC valves are shown in the DC Table. Figures are based on nominal values and will vary slightly depending on operating voltage and coil tolerances.

A, B, C, MB and V9 Series

Valve Series	AC Power Consumption Ratings	
	VA Holding	VA Inrush
Two-way B	17	9.7
Three-way B	19	12
Two-way C	25	16
Three-way C	25	16
Two-way A	122	49
Three-way A	82	40
Three-way MB	12	6.5
Four-way MB	12	6.5
Four-way V9*	32.5	17.5

* Per coil

Valve Series	Current (Amperes) 6 Volt	DC Current Consumption Ratings		
		Coil Type		
		12 Volt	24 Volt	120 Volt
Two-way B	1.05	0.53	0.26	0.05
Three-way B	1.05	0.53	0.26	0.05
Two-way C	1.17	0.58	0.29	0.06
Three-way C	1.17	0.58	0.29	0.06
Two-way A	-	-	-	-
Three-way A	2.33	1.17	0.58	0.12
Three-way MB	0.83	0.42	0.21	0.04
Four-way MB	0.83	0.42	0.21	0.04
Four-way V9*	1.42	0.71	0.35	0.07

* Per coil

DELIVERY INFORMATION

STANDARD PRODUCTS (Product Class 1)

Parker Fluid Control Division establishes a classification for every item made that identifies how long it should take to build that item. This designation is called “**Product Class**”. Those items that are the most common are being referred to as “**STANDARD PRODUCTS**”.

We have a unique structure in the industry which allows for modular construction of our products. To enhance our service to our customers we have focused our Product Class One offering on pressure vessels and integrated coil kits. The ability to “mix and match” pressure vessels and coil kits allows distribution to offer a variety of product combinations unsurpassed in market place.



*Skinner products shown



This modular design, will give you flexibility with stocking our products. Choose from the list of Product Class Ones located after the table of contents to begin stocking readily available products, 50 or less ships in 24 hours!

* Assembled combinations of Product Class One items ship in 5 working days.

NON STANDARD PRODUCTS

These products are made to order. Lead times are typically to the chart to the right, listed by product class. An electronic price file is available to you which identifies each item's “product class” and “lead time”. This file is available on PHconnect.com for download.

The items marked “CF” in the price book refer to consult factory. Some of the items may have been obsoleted and our customer service and technical sales departments can help you with cross overs to more current valves. Contact your customer service representative for assistance.

PRODUCT CLASS

- 1: Ships within 24 hours
- **50 pieces or less ship within 24 hours
- **Quantities greater than 50 pieces will ship within 5 working days
- 2: Ships within 5 working days
- 3: Ships within 15 working days
- 4: Ships within 20 working days
- 6: Ships within 30 working days
- 7: Ships within 60 working days
- N: Date to be Assigned
- CF: Consult Factory

Offer Of Sale

The items described in this document are hereby offered for sale at prices to be established by Parker Hannifin Corporation, its subsidiaries and its authorized distributors. This offer and its acceptance by any customer ("Buyer") shall be governed by all of the following Terms and Conditions. Buyer's order for any item described in its document, when communicated to Parker Hannifin Corporation, its subsidiary or an authorized distributor ("Seller") verbally or in writing, shall constitute acceptance of this offer.

1. **Terms and Conditions of Sale:** All descriptions, quotations, proposals, offers, acknowledgments, acceptances and sales of Seller's products are subject to and shall be governed exclusively by the terms and conditions stated herein. Buyer's acceptance of any offer to sell is limited to these terms and conditions. Any terms or conditions in addition to, or inconsistent with those stated herein, proposed by Buyer in any acceptance of an offer by Seller, are hereby objected to. No such additional, different or inconsistent terms and conditions shall become part of the contract between Buyer and Seller unless expressly accepted in writing by Seller. Seller's acceptance of any offer to purchase by Buyer is expressly conditional upon Buyer's assent to all the terms and conditions stated herein, including any terms in addition to, or inconsistent with those contained in Buyer's offer. Acceptance of Seller's products shall in all events constitute such assent.

2. **Payment:** Payment shall be made by Buyer net 30 days from the date of delivery of the items purchased hereunder. Any claims by Buyer for omissions or shortages in a shipment shall be waived unless Seller receives notice thereof within 30 days after Buyer's receipt of the shipment. The minimum order amount is \$125.00 net, unless otherwise noted on the quotation.

3. **Delivery:** Unless otherwise provided on the face hereof, delivery shall be made F.O.B. Seller's plant. Regardless of the method of delivery, however, risk of loss shall pass to Buyer upon Seller's delivery to a carrier. Any delivery dates shown are approximate only and Seller shall have no liability for any delays in delivery. Shipments are made by common carrier. Any premium freight must be requested and paid for by the Buyer.

4. **Warranty:** Seller warrants that the items sold hereunder shall be free from defects in material or workmanship for a period of 2 years from the date of shipment to Buyer, or 2,000 hours of use, whichever expires first. Exception to this is the Angle Body Valve line has a 1 year warranty. THIS WARRANTY COMPRISES THE SOLE AND ENTIRE WARRANTY PERTAINING TO ITEMS PROVIDED HEREUNDER. SELLER MAKES NO OTHER WARRANTY, GUARANTEE, OR REPRESENTATION OF ANY KIND WHATSOEVER. ALL OTHER WARRANTIES, INCLUDING BUT NOT LIMITED TO, MERCHANTABILITY AND FITNESS FOR PURPOSE, WHETHER EXPRESS, IMPLIED, OR ARISING BY OPERATION OF LAW, TRADE USAGE, OR COURSE OF DEALING ARE HEREBY DISCLAIMED. NOTWITHSTANDING THE FOREGOING, THERE ARE NO WARRANTIES WHATSOEVER ON ITEMS BUILT OR ACQUIRED WHOLLY OR PARTIALLY, TO BUYER'S DESIGNS OR SPECIFICATIONS.

5. **Limitation Of Remedy:** SELLER'S LIABILITY ARISING FROM OR IN ANY WAY CONNECTED WITH THE ITEMS SOLD OR THIS CONTRACT SHALL BE LIMITED EXCLUSIVELY TO REPAIR OR REPLACEMENT OF THE ITEMS SOLD OR REFUND OF THE PURCHASE PRICE PAID BY BUYER, AT SELLER'S SOLE OPTION. IN NO EVENT SHALL SELLER BE LIABLE FOR ANY INCIDENTAL, CONSEQUENTIAL OR SPECIAL DAMAGES OF ANY KIND OR NATURE WHATSOEVER, INCLUDING BUT NOT LIMITED TO LOST PROFITS ARISING FROM OR IN ANY WAY CONNECTED WITH THIS AGREEMENT OR ITEMS SOLD HEREUNDER, WHETHER ALLEGED TO ARISE FROM BREACH OF CONTRACT, EXPRESS OR IMPLIED WARRANTY, OR IN TORT, INCLUDING WITHOUT LIMITATION, NEGLIGENCE, FAILURE TO WARN OR STRICT LIABILITY.

6. **Changes, Reschedules and Cancellations:** Buyer may request to modify the designs or specifications for the items sold hereunder as well as the quantities and delivery dates thereof, or may request to cancel all or part of this order, however, no such requested modification or cancellation shall become part of the contract between Buyer and Seller unless accepted by Seller in a written amendment to this Agreement. Acceptance of any such requested modification or cancellation shall be at Seller's discretion, and shall be upon such terms and conditions as Seller may require.

7. **Special Tooling:** A tooling charge may be imposed for any special tooling, including without limitation, dies, fixtures, molds and patterns, acquired to manufacture items sold pursuant to this contract. Such special tooling shall be and remain Seller's property notwithstanding payment of any charges by

Buyer. In no event will Buyer acquire any interest in apparatus belonging to Seller which is utilized in the manufacture of the items sold hereunder, even if such apparatus has been specially converted or adapted for such manufacture and notwithstanding any charges paid by Buyer. Unless otherwise agreed, Seller shall have the right to alter, discard or otherwise dispose of any special tooling or other property in its sole discretion at any time.

8. **Buyer's Property:** Any designs, tools, patterns, materials, drawings, confidential information or equipment furnished by Buyer or any other items which become Buyer's property, may be considered obsolete and may be destroyed by Seller after two (2) consecutive years have elapsed without Buyer placing an order for the items which are manufactured using such property. Seller shall not be responsible for any loss or damage to such property while it is in Seller's possession or control.

9. **Taxes:** Unless otherwise indicated on the face hereof, all prices and charges are exclusive of excise, sales, use, property, occupational or like taxes which may be imposed by any taxing authority upon the manufacture, sale or delivery of the items sold hereunder. If any such taxes must be paid by Seller or if Seller is liable for the collection of such tax, the amount thereof shall be in addition to the amounts for the items sold. Buyer agrees to pay all such taxes or to reimburse Seller therefore upon receipt of its invoice. If Buyer claims exemption from any sales, use or other tax imposed by any taxing authority, Buyer shall save Seller harmless from and against any such tax, together with any interest or penalties thereon which may be assessed if the items are held to be taxable.

10. **Indemnity For Infringement of Intellectual Property Rights:** Seller shall have no liability for infringement of any patents, trademarks, copyrights, trade dress, trade secrets or similar rights except as provided in this Part 10. Seller will defend and indemnify Buyer against allegations of infringement of U.S. patents, U.S. trademarks, copyrights, trade dress and trade secrets (hereinafter "Intellectual Property Rights"). Seller will defend at its expense and will pay the cost of any settlement or damages awarded in an action brought against Buyer based on an allegation that an item sold pursuant to this contract infringes the Intellectual Property Rights of a third party. Seller's obligation to defend and indemnify Buyer is contingent on Buyer notifying Seller within ten (10) days after Buyer becomes aware of such allegations of infringement, and Seller having sole control over the defense of any allegations or actions including all negotiations for settlement or compromise. If an item sold hereunder is subject to a claim that it infringes the Intellectual Property Rights of a third party, Seller may, at its sole expense and option, procure for Buyer the right to continue using said item, replace or modify said item so as to make it non-infringing, or offer to accept return of said item and return the purchase price less a reasonable allowance for depreciation. Notwithstanding the foregoing, Seller shall have no liability for claims of infringement based on information provided by Buyer, or directed to items delivered hereunder for which the designs are specified in whole or part by Buyer, or infringements resulting from the modification, combination or use in a system of any item sold hereunder. The foregoing provisions of this Part 10 shall constitute Seller's sole and exclusive liability and Buyer's sole and exclusive remedy for infringement of Intellectual Property Rights.

If a claim is based on information provided by Buyer or if the design for an item delivered hereunder is specified in whole or in part by Buyer, Buyer shall defend and indemnify Seller for all costs, expenses or judgments resulting from any claim that such item infringes any patent, trademark, copyright, trade dress, trade secret or any similar right.

11. **Force Majeure:** Seller does not assume the risk of and shall not be liable for delay or failure to perform any of Seller's obligations by reason of circumstances beyond the reasonable control of Seller (hereinafter "events of Force Majeure"). Events of Force Majeure shall include without limitation, accidents, acts of God, strikes or labor disputes, acts, laws, rules or regulations of any government or government agency, fires, floods, delays or failures in delivery of carriers or suppliers, shortages of materials and any other cause beyond Seller's control.

12. **Entire Agreement/Governing Law:** The terms and conditions set forth herein, together with any amendments, modifications and any different terms or conditions expressly accepted by Seller in writing, shall constitute the entire Agreement concerning the items sold, and there are no oral or other representations or agreements which pertain thereto. This Agreement shall be governed in all respects by the law of the State of Ohio. No actions arising out of the sale of the items sold hereunder or this Agreement may be brought by either party more than two (2) years after the cause of action accrues.