

INSTALLATION & OPERATIONS
MANUAL FOR
LK-2000™ AND LK-2000V™

OZONE SYSTEM FOR DELUXE OR CUSTOM POOLS

MANUFACTURED BY

DEL INDUSTRIES

3428 Bullock Lane
San Luis Obispo, CA 93401
800-676-1335

IMPORTANT SAFETY INSTRUCTIONS

When installing and using the DELZONE LK-2000™ & LK-2000V™, basic safety precautions should always be followed.

Be sure all the electrical power is shut OFF at the main circuit breaker before installing the LK-2000™ & LK-2000V™.

1. **READ AND FOLLOW ALL INSTRUCTIONS**
2. All permanent electrical connections should be made by a qualified electrician.
3. For cord- and plug-connected units, connect to a grounded, grounding type receptacle only. If the ozone generator's electrical connection is to be attached to the pool controls, be sure the pool controls are protected by a Ground Fault Circuit Interrupter (G.F.C.I.). If the LK-2000™ & LK-2000V™ is connected to an independent electrical supply, then the G.F.C.I. must be installed between the ozone generator and the electrical supply.
4. Do not bury cord.
5. **WARNING:** To reduce the risk of electric shock, replace damaged cord immediately.
6. A pressure wire connector is provided on the outside of the unit to permit connection to a minimum No. 8 AWG (8.4 mm²) solid bonding conductor between this point and any metal equipment, metal enclosures of electrical equipment, metal water pipe, or conduit within five (5) feet (1.5m) of the unit as needed to comply with local requirements. Install at least 5 feet (1.5m) from the inside wall of the pool and one foot above the maximum water level to prevent water from contacting electrical equipment using nonmetallic tubing.
7. The LK-2000™ & LK-2000V™ must be installed in an outdoor location, or indoors in a forced air ventilated room. Install so that the orientation is as shown in Illustration 1. This will provide water drainage of the generator to protect electrical components.
8. The LK-2000™ & LK-2000V™ lamp emits ultraviolet light which is harmful to your eyes and skin if exposed. Always have the electrical power OFF when exposing the lamp.
9. Mount the LK-2000™ & LK-2000V™ so that it is inaccessible to anyone in the pool. Never attempt any servicing while unit is wet.
10. Follow all applicable electrical codes.
11. Plastic ozone supply tubing is supplied with the LK-2000™ & LK-2000V™. Never replace this tubing with metal tubing.
12. **SAVE THESE INSTRUCTIONS.**

TABLE OF CONTENTS

SAFETY INSTRUCTIONS	1
TABLE OF CONTENTS	2
PRELIMINARIES	3
INSTALLATION	
Tools and Materials Required	6
Mounting the Ozone Generator	6
Plumbing the Injector Manifold (LK-2000V™)	7-8
Flow Meter Test (LK-2000V™)	8
Plumbing the Injector Manifold (LK-2000™)	8
Ozone Supply Tubing Connection	9
Booster Pump Installation (Optional)	9
Isolation Valve Installation (Optional w/LK-2000V™)	10
ELECTRICAL CONNECTIONS	11
OPERATION	
Final Check and Start Up	11
MAINTENANCE	12-13
PARTS LIST	13
TROUBLE SHOOTING	
Green Power Indicator Light is OFF	14
Red Service Indicator Light is ON	14
Insufficient Air Flow	14
Water Flow Below Normal	14
Wiring Diagram	15
WARRANTY	16

PRELIMINARIES

Do not invalidate your warranty. Read and understand all of the instructions before you start any of the installation. If you have questions, call DEL at 800-676-1335 or 805-541-1601.

This manual covers both the LK-2000™(optional pressure system package) and the LK-2000V™(vacuum system) - differences are noted in the text and illustrations. Each ozone generator system is comprised of the following components:

1. DEL LK-2000™ or LK-2000V™ Ozone Generator
2. DEL Ozone Injector Assembly
3. Booster Pump (optional)
4. DEL Ozone Mixing Tower - MX-600(Optional)
5. Isolation Valve (Optional with LK-2000V™)

DEL LK-2000™ / LK-2000V™ Ozone Generator:

The LK-2000™/LK-2000V™ has been sized according to the application, water volume, and pool usage. The LK-2000™/LK-2000V™ generates the ozone that is injected into your pool. The ozone generator will produce the ozone via ultraviolet ray technology.

DEL Adjustable Injector Manifold:

The injector assembly is used to efficiently mix the ozone into the water. It may be plumbed directly into the pool's main return line or into a bypass line on the pool's main return line using a booster pump. In either case, the injector must be plumbed after all pool equipment, such as filters and heaters.

Booster Pump (Optional):

A booster pump can be plumbed into a bypass line, from the pool's main return line, diverting water to operate the injector assembly and/or mixing tower. This bypass loop is installed after the pool filter and heater systems.

DEL MX-600™ Ozone Mixing Tower (Optional):

The mixing system should be used if the distance between the equipment room and the pool is less than thirty feet. It is designed to maximize the transfer of ozone into the water and to provide a means of de-gasing the water stream.

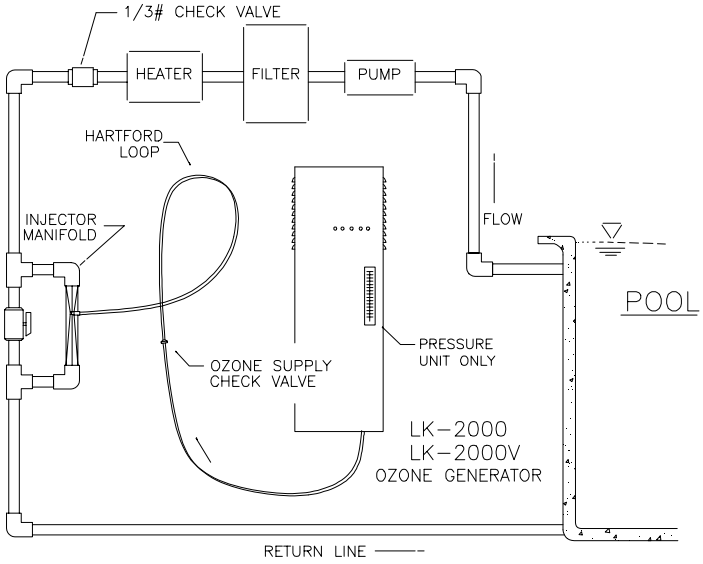

Illustration 1-a: Standard Installation

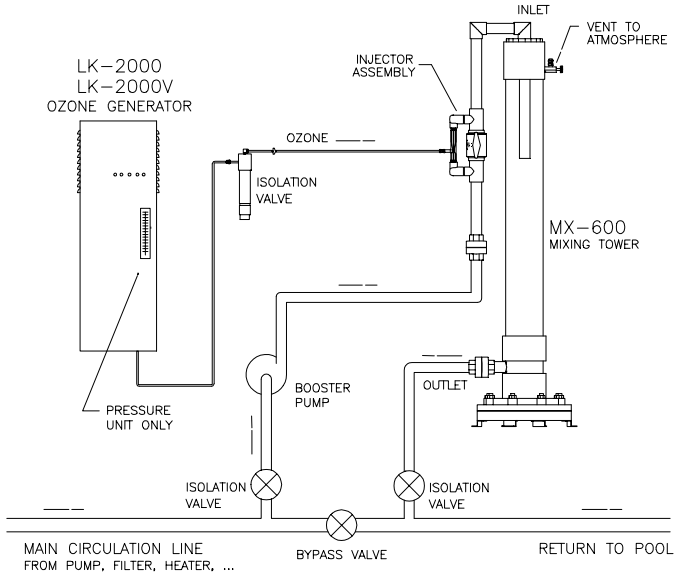

Illustration 1-b: Booster Pump Installation

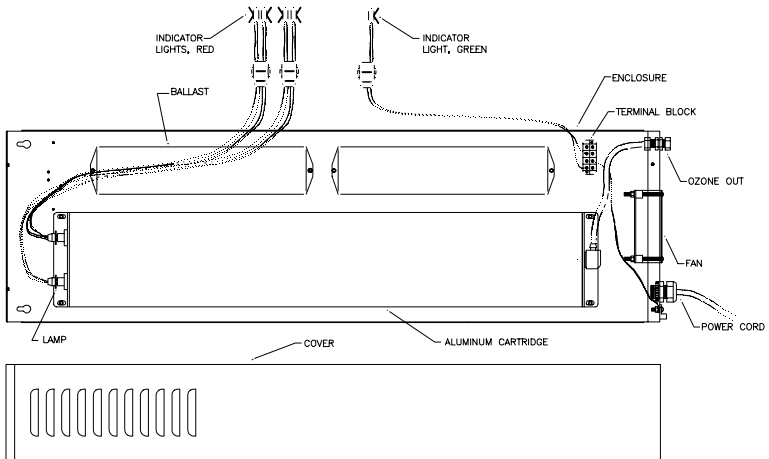

Illustration 2: LK-2000V™ Assembly Drawing

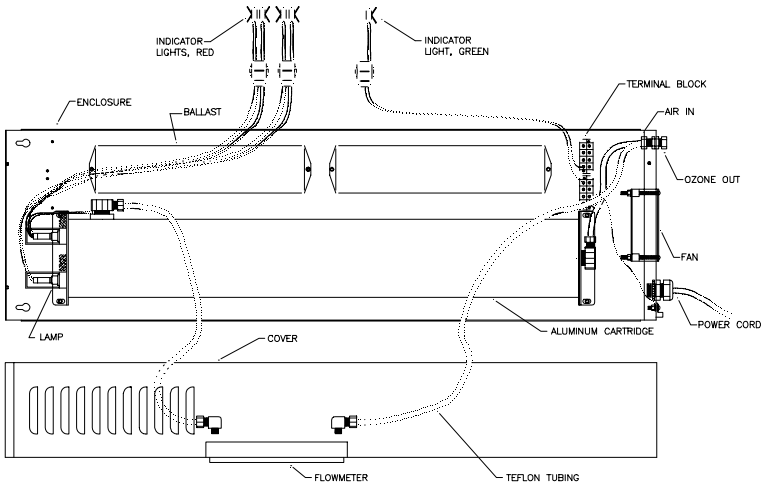

Illustration 3: LK-2000™ Assembly Drawing

INSTALLATION

TOOLS AND MATERIALS REQUIRED

The following is a list of the tools and materials needed to install, operate and service the DEL LK-2000™ & LK-2000V™ Ozone Generator.

Drill	Drill Bits
Phillips and Standard Screw Drivers	Tape Measure
Adjustable or Open-ended Wrenches	Pencil or Scribe
Wall Anchors appropriate for Mounting surface	Volt/Ohm Meter (DMM)
	Scissors or Knife

1. All plumbing and electrical connections should be made by qualified professionals.
2. Before following any of the instructions below, be sure you read and understand them completely.
3. Turn off all existing pool equipment at the main electrical service panel before proceeding with any installation maintenance or service procedures.
4. All components should be well ventilated. Allow for adequate air space around each component (approximately 4 inches on sides and bottom / 36 inches on top).
5. The equipment room must provide adequate air circulation.

MOUNTING THE OZONE GENERATOR

Install the DEL LK-2000™ / LK-2000V™ unit right side up with the electrical and tubing connections on the bottom. The unit should be mounted to a vertical surface with a minimum of four inches of air space below and on each side of the unit and 36 inches above, for easy lamp replacement.

Remove the four screws (two on bottom, two on top) securing the enclosure cover to the base-plate. Lift the cover off and hold it while disconnecting the wiring harness connectors, then set the cover aside. All five indicator lamps should remain attached to the cover. Install appropriate hardware (not included) through the four holes on the back of the base plate to secure it to a vertical surface. Reverse the steps above to reattach the enclosure cover. Be sure to match the letters on the connectors when reconnecting the wiring.

PLUMBING THE INJECTOR MANIFOLD (LK-2000V™)

Install the adjustable injector manifold directly into the pool's main return line. If a bypass loop is required, install the injector into the bypass loop after the booster pump. In either case, the injector must be plumbed in AFTER all pool equipment. It should be installed as close to the equipment and as far from the pool as possible.

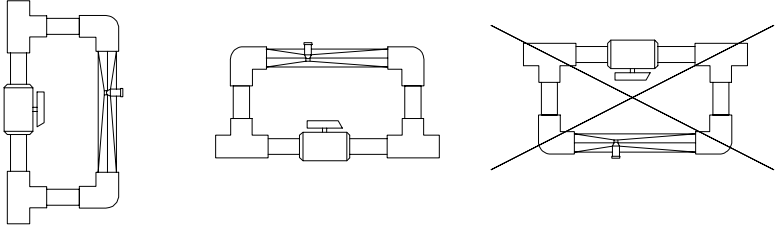

Illustration 4: Injector Mounting Diagram

Close any valves that will help prevent the pool system from draining. Locate an appropriate section of the return line, hold the injector manifold against the pipe and mark the length. Subtract 2 3/4" from the overall length. Mark this point, and cut out the section (about 13"). Install the injector manifold with PVC cement. Be very careful to observe and follow the correct water flow direction (Illustration 8). The injector manifold can be installed in either a vertical or horizontal position in the return line, but should **not** be installed with outlet facing down (Illustration 4).

NOTE: If the pool equipment is located above the water level of the pool, you must install the clear PVC DELCheck™ 1/3# check valve in the return line after all the pool equipment but before the DEL Adjustable Injector Manifold. (See Illustration 1-a)

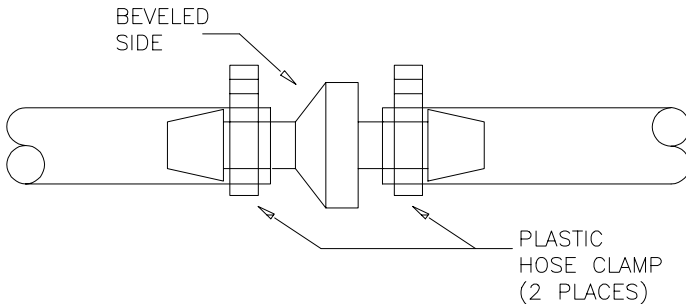

Illustration 5: Check Valve

FLOW METER TEST (LK-2000V™)

Locate the flowmeter test assembly and secure the tubing to the barb fitting on the DEL Adjustable Injector Manifold. Turn on the pool pump and slowly turn the ball valve in a clockwise direction (toward closed) until the middle of the ball in the flowmeter floats just at the indicator line. Hold the flowmeter vertically with top side up. If the ball bounces up and down, use the average of the movement as the set point. The Adjustable Injector Manifold is now correctly calibrated. Remove flowmeter assembly and proceed with ozone supply tubing connection. Reconnect flowmeter periodically to make sure that adjustable injector is properly adjusted.

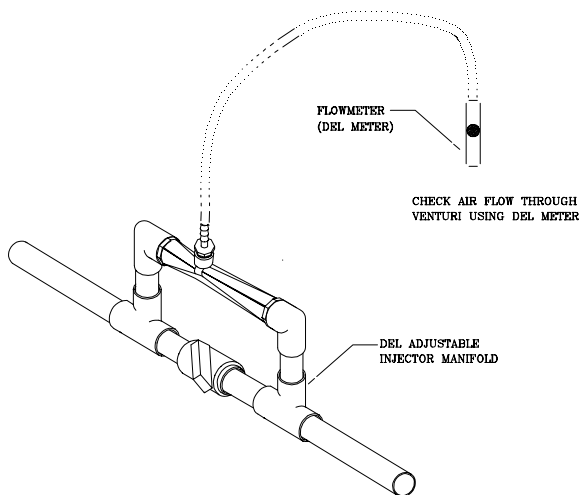

Illustration 6: Flow Meter Test

PLUMBING THE INJECTOR MANIFOLD (LK-2000™)

Plumb the Adjustable Injector Manifold for the LK-2000™ following the installation instructions as described in the LK-2000V™ section. Connect the ozone supply tubing as described in the following section. Adjust the ball valve on the injector manifold until the air flow meter on the front panel reads about 40 scfh. Next, throttle the flow meter to approximately 35scfh.

OZONE SUPPLY TUBING CONNECTION

If the generator is mounted above the water line attach one end of ozone supply tubing to the ozone supply connector on either the LK-2000™ or the LK-2000V™. Attach the other end directly to the Adjustable Injector Manifold and secure it with the plastic hose clamp provided. Locate the ozone supply check valve and install it into ozone supply tubing by cutting the tubing and securing it on both ends of the check valve with plastic hose clamps as shown in Illustration 5.

NOTE: Be sure the beveled side of the ozone supply check valve is pointing in the direction of the injector (Illustration 5).

NOTE: If the generator is mounted below the water line, the ozone supply tubing *must* be run from the generator to a point above the water line. A Hartford Loop *must* be used at this point.

To make a Hartford Loop, simply coil the tubing into a complete circle about 6" diameter, and fasten it above the water line. The Hartford Loop will act as a water trap to prevent water from running back to the generator in case the check valve fails. The supplied plastic check valve should be installed in the ozone supply tubing near the loop, between the generator and the loop. (See Illustration 1-a)

BOOSTER PUMP INSTALLATION (Optional)

Plumb the bypass loop by installing two tee fittings a minimum of 24 inches apart in the main return line AFTER all other system components (filters, heaters). Plumb the loop with two inch pipe and connect from the first tee (inlet to bypass loop) into the booster pump through the injector assembly or the mixing system and back into the second tee (outlet from bypass loop). A valve should be placed on each tee to allow the bypass loop to be isolated. (See Illustration 1-b and Illustration 7). Follow the pump manufacturer's instructions for mounting and wiring the booster pump.

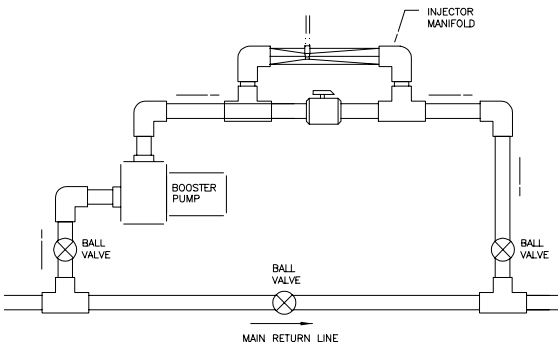

Illustration 7: Bypass Loop Schematic

ISOLATION VALVE INSTALLATION (Optional w/ LK-2000V™)

The DEL isolation valve acts as a water trap to prevent water from backing up into the ozone generator. Use the clamps and screws provided to mount the isolation valve vertically with the tubing connections on top (See Illustration 8). The DEL isolation valve may periodically release a small amount of water. Be sure to locate the valve in an area which will accommodate this water discharge.

Use a section of the ozone supply tubing to connect the ozone outlet on the bottom of the LK-2000™ to the fitting on top of the isolation valve. Use another section of tubing to connect the lower fitting on the isolation valve to the hose fitting on the adjustable injector manifold. Secure the tubing connections on the isolation valve and injector manifold with the clamps provided.

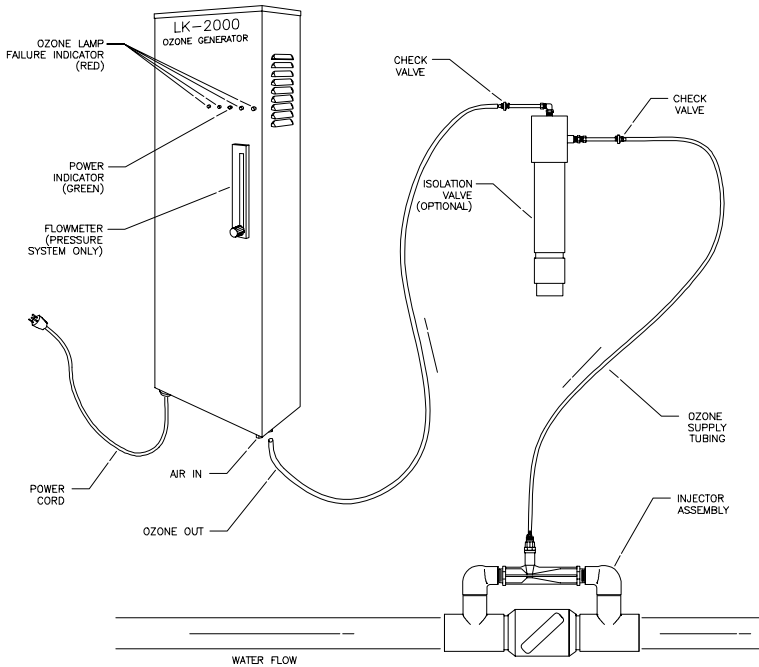

Illustration 8: Overview of LK-2000™ / LK-2000V™

ELECTRICAL CONNECTIONS

DEL LK-2000™ & LK-2000V™ OZONE GENERATOR

The LK-2000™ must be wired to operate with the pool's filtration system or connected to a separate timer system which is programmed to operate simultaneously with the pump.

If the LK-2000™ electrical connection will be attached directly to the pool controls, be sure the pool controls are protected by a Ground Fault Circuit Interrupter (G.F.C.I.). If the LK-2000™ is connected to an independent electrical supply, then a G.F.C.I. must be installed between the LK-2000™ and the electrical supply.

BOOSTER PUMP (*optional*)

Wire the booster pump into the main pump controls. The booster pump and the main pump must always run simultaneously. The booster pump power source should have a dedicated 20 amp circuit breaker.

OPERATION

FINAL CHECK AND START-UP

Double check all electrical and plumbing connections before turning on the main power supply. When you are satisfied that the entire installation is correct, perform the following procedures:

Start-up Procedure

1. Open all valves (except on the injector manifold) and turn ON the pool equipment at the main electrical service panel.
2. Check all glued joints and clamped or threaded fittings for leaks.
3. Check for bubbles entering the pool through the return line.

The LK-2000™ / LK-2000V™ will now operate automatically to keep your pool water clean and clear. Contact DEL at 800-676-1335 or your local dealer for a Water Chemistry Manual (part number 4-0392) for instructions on how to establish a routine water maintenance schedule. Below is recommended operating parameters:

MEASUREMENT	RECOMMENDED LEVEL
Total Alkalinity:	80-140 ppm
pH:	7.4-7.6
Free Chlorine:	0.5-1.0 ppm (optional)
Free Bromine:	1.0-2.0 ppm (optional)

MAINTENANCE

Once a week, check for the following:

1. Check that the LK-2000™ is operating. (Green power indicator light should be “on”.)
2. Check each one of four red ozone service indicator lights. These lights will remain “off” during normal operation. If a light is “on”, lamp service is required.
3. LK-2000™ only: Note the reading on the Air Flow Meter. It should always indicate the correct air flow rate for the LK-2000™.
4. At the pool, there should be bubbles entering through the return lines.
5. If a Mixing Tower is installed, there should be a swirling bubble pattern inside the mixer.
6. Replace old lamps. (See illustration 9)

CHANGING THE LK-2000™ LAMP

Turn off the electrical power. Remove the two screws on the front bottom part of the generator and the two on the top. Holding the cover, carefully disconnect the connectors attached to the wiring harness (make sure that all five indicator light lamps stay on the cover plate). Place the cover aside.

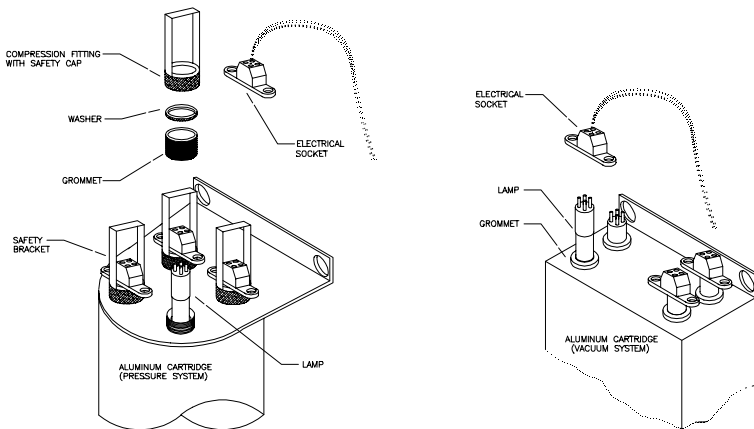

Illustration 9: Lamp Replacement

LAMP REPLACEMENT FOR LK-2000™

The lamps are contained inside the aluminum cartridge hanging on the back wall inside the enclosure. Disconnect the lamp electrical socket by rocking gently and pulling upward from the lamp end (see Ill. 9). Using a pair of pliers, loosen the knurled compression nut and remove the nut and washer from the lamp cartridge. Gently loosen the rubber seal which retains the lamp and pull the lamp up and out of the cartridge. Remove the seal from the old lamp. Lower the new lamp into the cartridge, being careful that it seats into the retainer bracket at the bottom of the cartridge. Slip the new rubber seal over the lamp end and install the washer and compression nut. Make sure the electric socket is installed correctly. Tighten the nut securely with pliers at least one full turn past hand tight. Connect the lamp electrical socket, and reinstall the cover.

LAMP REPLACEMENT FOR LK-2000V™

Disconnect all four lamp electrical sockets, as described above. Remove the four nuts holding the aluminum rectangular cartridge, and place the cartridge on a flat surface exposing the lamps. Remove the grommet from the old lamp on top of the cartridge and pull the end of the lamp from the clamp (attached to the inner side of the cartridge). Then, slide the old lamp out through the top opening. Replace the grommet with a new one and slide the new lamp in, pushing its end into the clamp. Attach the cartridge to the enclosure, connect all four electrical sockets, and reinstall the cover.

REPLACEMENT PARTS LIST

1. Lamp with Seal (LK-2000™ Pressure System) 9-0347
2. Lamp (LK-2000V™ Vacuum System) 5-0349
3. Ballast, 120V/60Hz (LK-2000™ Pressure System) 5-0090
4. Ballast, 120V/60Hz (LK-2000V™ Vacuum System) ... 5-0781
5. Ballast, 240V/60Hz 5-0544
6. Ballast, 240V, 50Hz 5-0252
7. Isolation Valve 9-0017
8. Adjustable injector IU-216
9. DEL 1/3# Check Valve CO-0101
10. 1/4" Check Valve 7-4012
11. 1/4"ID x 3/8"OD Tubing PVC 7-0594
12. Grommet, Lamp Cartridge 7-0539

TROUBLE SHOOTING

There are four areas to check to determine the location of any problem:

1. The green indicator light should remain ON during operation
2. The red indicator light should remain OFF during operation
3. Presence of ozone bubbles in the water
4. The condition of the water

SYMPTOM: *Green power indicator light OFF*

PROBABLE CAUSE	CORRECTIVE ACTION
1. No power to unit	1A. Check power source and cord
2. Tripped circuit breaker	2A. Reset circuit breaker
3. G.F.C.I. tripped	3A. Reset G.F.C.I.
4. Defective electrical system	4A. Return for service/repair

SYMPTOM: *Red service indicator light ON*

PROBABLE CAUSE	CORRECTIVE ACTION
1. Lamp disconnected	1A. Reconnect
2. Lamp burnt out	2A. Replace lamp
3. Ballast resistance (See illustration 7 or 8)	3A. Check resistance across ballast: Black to White 6 ohms Black to Blue 49 ohms White to Blue 55 ohms

SYMPTOM: *Insufficient air flow*

PROBABLE CAUSE	CORRECTIVE ACTION
1. Dirty water filter	1A. Clean filter
2. Poor air flow	2A. Readjust air flow
3. Air flow meter	3A. Readjust air flow meter
4. Ozone supply tubing leaks	4A. Check all fitting/tubing connections
5. Booster pump	5A. Check power supply, check electrical connections, repair, replace as necessary.

SYMPTOM: *Water flow below normal*

PROBABLE CAUSE	CORRECTIVE ACTION
1. Dirty water filter	1A. Clean filter
2. Booster pump	2A. Check power supply, check electrical connections, repair, replace as necessary.

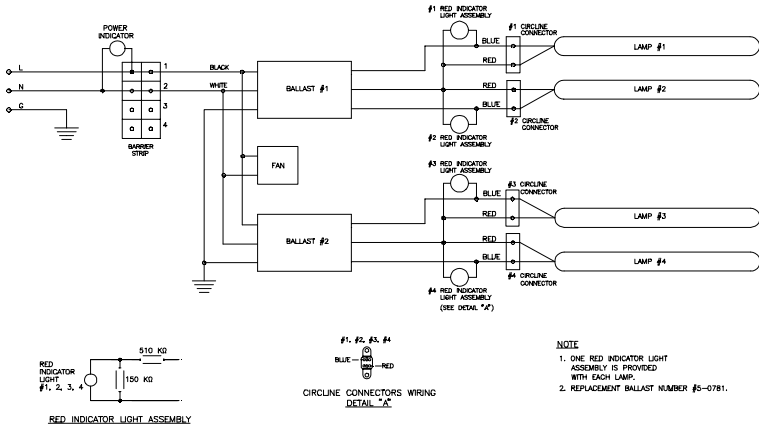

Illustration 10: Wiring Diagram - 110V/60Hz

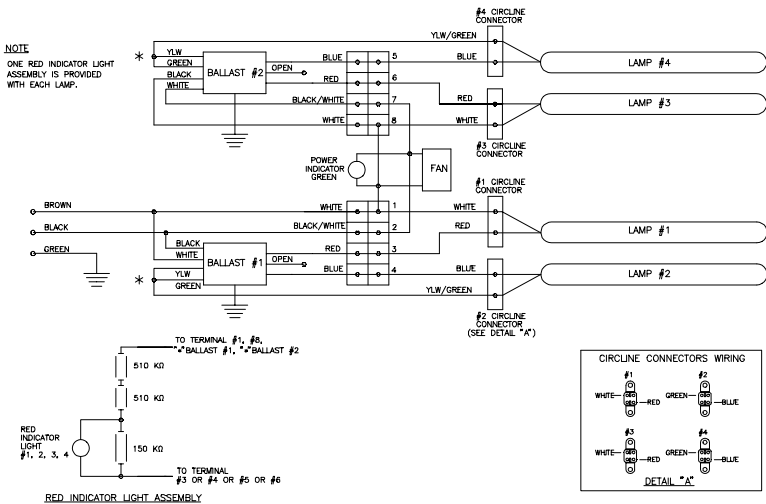

Illustration 11: Wiring Diagram - 240V/50Hz

DEL Industries · ONEYEAR LIMITED WARRANTY

The warranty set forth below applies to the DEL INDUSTRIES, INC. sold by DEL INDUSTRIES, INC. and its authorized dealers. This limited warranty is given only to the first retail purchaser of such products and is not transferable to any subsequent owners or purchasers of such products. DEL INDUSTRIES, INC. warrants that It or its authorized dealers will repair or replace, at its option, any part of such products proven to be defective in materials or workmanship within ONE (1) year of the date of retail purchase of such products FOR A FULL ONE YEAR WARRANTY PERIOD. (All parts) ANY REPAIR OR REPLACEMENT WILL BE WARRANTED ONLY FOR THE BALANCE OF THE ORIGINAL WARRANTY PERIOD. NOTE: USE ONLY DEL INDUSTRIES, INC. AUTHORIZED REPLACEMENT PARTS. USE OF ANY Other PART(S) WILL AUTOMATICALLY VOID THIS WARRANTY. **WARRANTY DOES NOT INCLUDE ANY OF THE FOLLOWING:** (a) any labor charges for troubleshooting, removal, or installation of such parts; (b) any repair or replacement of such parts necessitated by faulty installation, improper maintenance, improper operation, misuse, abuse, negligence, accident, fire, repair materials, and/or unauthorized accessories; (c) any such products Installed without regard to required local codes and accepted trade practices; (d) ANY IMPLIED WARRANTY OF MERCHANTABILITY OR IMPLIED WARRANTY OF FITNESS FOR PARTICULAR PURPOSE, AND SUCH WARRANTIES ARE HEREBY DISCLAIMED: AND (e) DEL INDUSTRIES, INC. SHALL NOT BE LIABLE UNDER ANY CIRCUMSTANCES FOR LOSS OF USE OF SUCH PRODUCTS, LOST PROFITS, DIRECT DAMAGES, INDIRECT DAMAGES, CONSEQUENTIAL DAMAGES AND/OR incidental DAMAGES. This warranty gives you specific legal rights. You may also have other rights which vary from state to state.

TO OBTAIN WARRANTY SERVICE

Contact: DEL Industries Inc. · 3428 Bullock Ln. · San Luis Obispo, CA · 93401

Customer Service Number : (805) 541-1601

When filing a claim, you must provide:

- 1) your name, mailing address and telephone number;
- 2) the selling dealer's name;
- 3) proof of date of purchase;
- 4) the date of failure;
- 5) a description of the failure.

After this information is provided, DEL INDUSTRIES, INC. will release a RETURN GOODS AUTHORIZATION (RGA) NUMBER. After receiving this number the part in question must be returned to DEL INDUSTRIES, INC., freight prepaid, with ***the RGA number clearly marked on the outside of the package***. All preauthorized defective parts must be returned to DEL INDUSTRIES, INC. within thirty (30) days. **Under no circumstances may any product be returned to DEL INDUSTRIES, INC. without prior authorization.** You must call or write first or your returned goods shipment will be refused. Upon receipt of preauthorized returned goods DEL INDUSTRIES, INC. will repair or replace, at DEL INDUSTRIES, INC.'s option, the defective product(s) and return them freight collect. To validate your warranty, fill in the enclosed warranty registration card and return it to DEL INDUSTRIES, INC. within ten (10) days of your purchase. Buyer's acceptance of the product and use thereof constitutes acceptance of these terms.