

OPERATOR'S AND ORGANIZATIONAL  
MAINTENANCE MANUAL

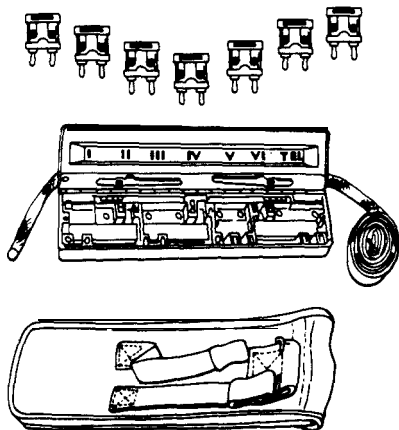

CONTROLS  
PAGE 2-0

PMCS  
PAGE 2-3

OPERATION  
PAGE 2-15

MAINTENANCE  
PAGES 3-0, 4-0

MANUAL TELEPHONE  
SWITCHBOARD SB-993/GT  
(NSN 5805-00-708-2202)



**5**

**SAFETY STEPS TO FOLLOW IF SOMEONE IS THE VICTIM OF ELECTRICAL SHOCK**

**1**

**DO NOT TRY TO PULL OR GRAB THE INDIVIDUAL**

**2**

**IF POSSIBLE, TURN OFF THE ELECTRICAL POWER**

**3**

**IF YOU CANNOT TURN OFF THE ELECTRICAL POWER, PULL, PUSH, OR LIFT THE PERSON TO SAFETY USING A WOODEN POLE OR A ROPE OR SOME OTHER INSULATING MATERIAL**

**4**

**SEND FOR HELP AS SOON AS POSSIBLE**

**5**

**AFTER THE INJURED PERSON IS FREE OF CONTACT WITH THE SOURCE OF ELECTRICAL SHOCK, MOVE THE PERSON A SHORT DISTANCE AWAY AND IMMEDIATELY START ARTIFICIAL RESUSCITATION**

## **WARNING**

Do not lay, place, or throw field wire on or near power lines or transformers. Dangerous high voltages exist at these structures, and severe shock or even death may result from contact between field wire and power lines. Follow the five emergency steps for electric shock. Be careful when using the SB-993/GT during storms, as lightning may pose a shock hazard.

## **WARNING**

Ninety to 100 volts dc may be present on the field wire terminals of the SB-993/GT. Don't take chances.

## **WARNING**

Adequate ventilation should be provided while using TRICHLOROTRIFLUOROETHANE. Prolonged breathing of vapor should be avoided. The solvent should not be used near heat or open flame, as the products of decomposition are toxic and irritating. Since TRICHLOROTRIFLUOROETHANE dissolves natural oils, prolonged contact with skin should be avoided. When necessary, use gloves (which the solvent cannot penetrate). If the solvent is taken internally, consult a physician immediately.



**\*TM 11-5805-294-12**

TECHNICAL MANUAL

HEADQUARTERS

NO 11-5805-294-12

DEPARTMENT OF THE ARMY

Washington, DC, 8 September 1983

**OPERATOR'S AND ORGANIZATIONAL  
MAINTENANCE MANUAL**

**MANUAL TELEPHONE SWITCHBOARD  
SB-993/GT  
(NSN 5805-00-708-2202)**

**REPORTING ERRORS AND RECOMMENDING  
IMPROVEMENTS**

You can help improve this manual. If you find any mistakes, or if you know of a way to improve the procedures, please let us know. Mail your letter or DA Form 2028 (Recommended Changes to Publications and Blank Forms) directly to: Commander, US Army Communications-Electronics Command and Fort Monmouth, ATTN: DRSEL-ME-MP, Fort Monmouth, New Jersey 07703. A reply will be furnished to you.

\*This manual supersedes TM 11-5805-294-15, dated 6 October 1959, including all changes.

	Page
HOW TO USE THIS MANUAL . . . . .	iii
CHAPTER 1 INTRODUCTION . . . . .	1-1
Section 1 General Information . . . . .	1-1
Equipment Description. . . . .	1-5
CHAPTER 2 OPERATING INSTRUCTIONS . . . . .	2-0
Section 1 Description and Use of Operator's Controls and Indicators. . . . .	2-1
Operator Preventive Maintenance Checks and Services . . . . .	2-3
Operation Under Usual Conditions . . . . .	2-7
Operation Under Unusual Conditions . . . . .	2-15
CHAPTER 3 OPERATOR MAINTENANCE. . . . .	3-0
ORGANIZATIONAL MAINTENANCE. . . . .	4-0
APPENDIX A REFERENCES. . . . .	A-1

APPENDIX B MAINTENANCE ALLOCATION  
CHART . . . . . B-0

C COMPONENTS OF END ITEM  
AND BASIC ISSUE ITEMS. . . . .C-0

D ADDITIONAL  
AUTHORIZATION  
LIST . . . . . D-0

E EXPENDABLE SUPPLIES AND  
MATERIALS LIST . . . . . E-0

HOW TO USE THIS MANUAL

Paragraphs in this manual are numbered by chapter and order of appearance within a chapter. A subject index appears at the beginning of each chapter and lists sections that are included in each chapter. A more specific subject index is located at the beginning of each section to help you find the exact paragraph you need.

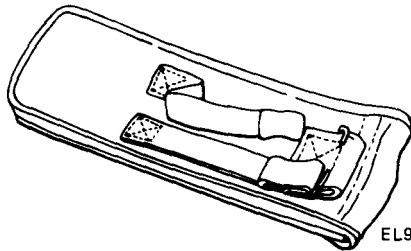
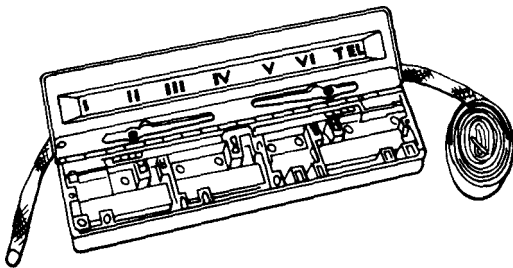
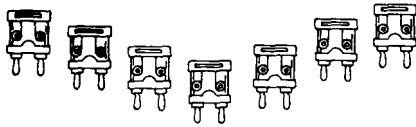

EL9DR002

MANUAL TELEPHONE SWITCHBOARD SB-993/GT



# CHAPTER 1

## INTRODUCTION

Subject	Section	Page
General Information . . . . .	I	1-1
Equipment Description and Data . . . . .	II	1-5

### Section I GENERAL INFORMATION

Subject	Para	Page
Scope . . . . .	1-1	1-2
Maintenance Forms, Records, and Reports . . . . .	1-2	1-2
Destruction of Army Electronics Materiel . . . . .	1-3	1-3
Administrative Storage. . . . .	1-4	1-3
Reporting Equipment Improvement Recommendations . . . . .	1-5	1-4
Nomenclature Cross-Reference List . . . . .	1-6	1-4

## **1-1. SCOPE.**

Type of Manual: Operator's and Organizational Maintenance.

Equipment Name and Model Number: Manual Telephone Switchboard SB-993/GT.

Purpose of Equipment: To provide terminal connections for six local battery telephone lines in the field.

## **1-2. MAINTENANCE FORMS, RECORDS, AND REPORTS.**

### **REPORTS OF MAINTENANCE AND UNSATISFACTORY EQUIPMENT**

Department of the Army forms and procedures used for equipment maintenance will be prescribed by TM 38-750, The Army Maintenance Management System (TAMMS).

### **REPORT OF PACKAGING AND HANDLING DEFICIENCIES**

Fill out and forward SF 364 (Report of Discrepancy (ROD)) as prescribed in AR 735-11-2/DLAR 4140.55/NAVMATINST 4355.73/AFR 400-54/MC0 4430.3E.

## **1-2. MAINTENANCE FORMS, RECORDS, AND REPORTS. (CONT)**

DISCREPANCY IN SHIPMENT REPORT (DISREP)  
(SF 361)

Fill out and forward Discrepancy in Shipment Report (DISREP) (SF 361) as prescribed in AR 55-38/ NAVSUPINST 4610.33B/AFR 75-18/MCO 4610.19C/ DLAR 4500.15.

## **1-3. DESTRUCTION OF ARMY ELECTRONICS MATERIEL.**

Destruction of Army electronics materiel to prevent enemy use shall be in accordance with TM 750-244-2.

## **1-4. ADMINISTRATIVE STORAGE**

Administrative storage of equipment issued to and used by Army activities will have preventive maintenance performed in accordance with the PMCS charts before storing. When removing the equipment from administrative storage, the PMCS should be performed to assure operational readiness.

## **1-5. REPORTING EQUIPMENT IMPROVEMENT RECOMMENDATIONS (EIR).**

If your manual telephone switchboard needs improvement, send us an EIR. Tell us what you don't like about your equipment. Let us know why You don't like the design or performance. Put it on an SF 368 (Quality Deficiency Report). Mail it to: Commander, US Army Communications-Electronics Command and Fort Monmouth, ATTN: DRSEL-ME-MP, Fort Monmouth, New Jersey 07703. A reply will be sent to you.

## **1-6. NOMENCLATURE CROSS-REFERENCE LIST.**

This list contains the common names used throughout this manual in place of official nomenclature.

---

Common Name	Official Nomenclature
switchboard	Manual Telephone Switchboard SB-993/GT
switchboard case	Switchboard Case CY-2589/GT
connector adapter	Connector Adapter U-184/GT
connector adapter holder	Connector Adapter Holder MT-2156/GT

## Section II EQUIPMENT DESCRIPTION AND DATA

Subject	Para	Page
Equipment Characteristics		
Capabilities, and Features. . . . .	1-7	1-5
Equipment Data . . . . .	1-8	1-5

### 1-7. EQUIPMENT CHARACTERISTICS, CAPABILITIES, AND FEATURES.

The manual telephone switchboard can provide terminal connections for six local battery telephone lines in the field.

#### CAPABILITIES AND FEATURES

Manually operated  
Highly portable

### 1-8. EQUIPMENT DATA.

The manual telephone switchboard consists of a switchboard case, connector adapter holder, mounting strap and seven connector adapters. Weights and dimensions for each component follow.

## 1-8. EQUIPMENT DATA. (CONT)

### Switchboard Case:

Weight . . . . .	5 oz
Width . . . . .	4 in.
Length . . . . .	12 in.
Height . . . . .	1 1/2 in.

### Connector Adapter Holder:

Weight . . . . .	24 oz
Width . . . . .	3 in.
Length . . . . .	12 in.
Height . . . . .	1 1/4 in.

### Connector Adapter:

Weight . . . . .	1 1/4 oz
Width . . . . .	1 3/8 in.
Length . . . . .	1 7/16 in.
Height . . . . .	1 1/16 in.

### Mounting Strap:

Weight . . . . .	2 oz
Width . . . . .	5/8 in.
Length . . . . .	84 in.

**1-8. EQUIPMENT DATA. (CONT)**

Manual Telephone Switchboard (assembled):

Weight . . . . .	40 oz
Width . . . . .	4 in.
Length . . . . .	12 in.
Height . . . . .	1 1/2 in.

## CHAPTER 2

### OPERATING INSTRUCTIONS

Subject	Section	Page
Description and Use of Operator's Controls and Indicators . . . . .	I	2-1
Operator Preventive Maintenance Checks and Services . . . . .	II	2-3
Operation Under Usual Conditions . . . . .	III	2-7
Operation Under Unusual Conditions . . . . .	IV	2-15



## Section I DESCRIPTION AND USE OF OPERATOR'S CONTROLS AND INDICATORS

### 2-1. DESCRIPTION AND USE OF OPERATOR'S CONTROLS AND INDICATORS.

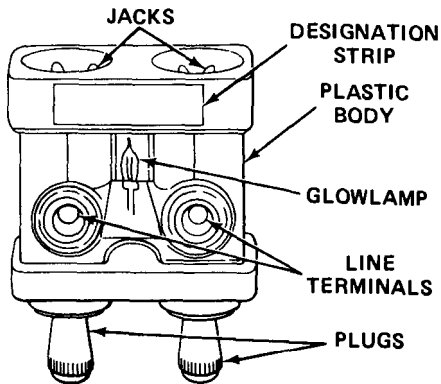

EL9DR003

**CONNECTOR ADAPTER.** A combination jack and plug that fits into the jacks of other adapters, allowing for line-to-line or conference calls. The plugs, which are thumb-screws, secure telephone lines at the line terminal points through clamping force. A glow lamp seated inside the adapter's clear-plastic body will light when an incoming call is received. A designation strip painted on the body of the adapter allows the operator to designate terminal lines in writing.

## 2-1. DESCRIPTION AND USE OF OPERATOR'S CONTROLS AND INDICATORS. (CONT)

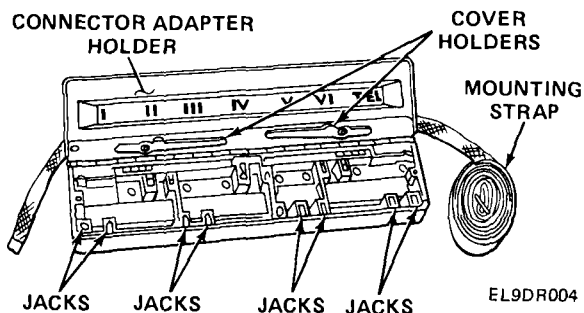

CONNECTOR ADAPTER HOLDER. Secures the seven connector adapters during operation, through the use of seven jacks located at the bottom of the unit. It also stores the adapters when they are not in use. The cover of the holder (where line terminal identification markings can be seen) is held open by two cover holders. The bottom of the holder is lined with rubber strips to prevent damage to the adapters when the switchboard is being transported. A 7-foot mounting strap allows the holder to be mounted and secured to a post or tree. It also holds the unit closed when not in operation.

**2-1. DESCRIPTION AND USE OF OPERATOR'S CONTROLS AND INDICATORS. (CONT)**

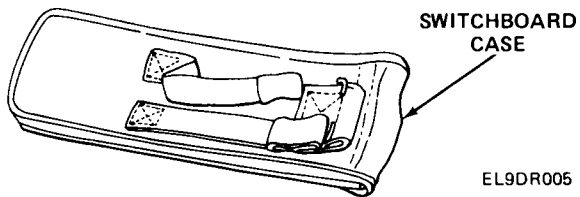

SWITCHBOARD CASE. Used to carry and protect the adapter connector holder. The case allows an operator to attach the holder to a cartridge or pistol belt.

**Section II OPERATOR PREVENTIVE MAINTENANCE CHECKS AND SERVICES**

Subject	Para	Page
General . . . . .	2-2	2-3
Operator Preventive Maintenance Checks and Services . . . . .	2-3	2-5

**2-2. GENERAL.**

**NOTE**

Always keep in mind the CAUTIONS and WARNINGS before you perform operator preventive checks and services (PMCS).

## **2-2. GENERAL. (CONT)**

Operator Preventive Maintenance: The systematic care, servicing and inspection of equipment to prevent the occurrence of trouble, reduction of downtime, and the maintaining of equipment in serviceable condition. To be sure that your equipment is always ready for your mission, you must complete scheduled preventive maintenance checks and services (PMCS).

Before operation, perform your B PMCS to be sure that your equipment is ready to go.

Monthly PMCS are important checks to keep serious problems from happening. Perform monthly as well as before operation PMCS if you are operating the equipment for the first time or have not operated the equipment for a month.

The EQUIPMENT IS NOT READY/AVAILABLE IF column tells you why your equipment cannot be used if the ITEM TO BE INSPECTED does not meet PROCEDURE needs.

The ITEM NUMBER column in the PMCS table is to be used as a source of item numbers for the TM number column on DA Form 2404, Equipment Inspection and Maintenance Worksheet, for recording PMCS results.

## **2-2. GENERAL. (CONT)**

Routine checks like cleaning, dusting, washing, checking for frayed cables, stowing items not in use, covering unused receptacles, and checking for loose nuts and bolts are not listed as PMCS checks. They are things you should do when you see that they must be done. If you find a routine check like one of those listed in your PMCS, it is because other operators have reported problems with this item.

Deficiencies that cannot be corrected must be reported to higher category maintenance personnel. Records and reports of preventive maintenance must be made in accordance with procedures given in TM 38-750.

## **2-3. OPERATOR PREVENTIVE MAINTENANCE CHECKS AND SERVICES.**

### **NOTE**

If your equipment must be in operation at all times, check the items that can be checked and serviced without disturbing operation. Make the complete checks and services when the equipment can be shut down.

## 2-3. OPERATOR PREVENTIVE MAINTENANCE CHECKS AND SERVICES. (CONT)

B - BEFORE OPERATION

M - MONTHLY

ITEM NO.	INTERVAL		ITEM TO BE INSPECTED PROCEDURE	EQUIPMENT IS NOT READY/ AVAILABLE IF:
	B	M		
1	●		Connector Adapters: Check to see if adapters are present and working.	Three or more connectors adapters are missing.
2		●	MODIFICATION WORK ORDERS (MWO's): Check the latest issue of DA PAM 310-1 to determine whether urgent MWO's have been applied.	URGENT MWO's are not applied.
3	*		Perform the operational checks as described in paragraph 2-6.	Equipment is not operational.

\*Do this check before each deployment to a mission location. This will permit any existing problems to be corrected before the mission begins. This check need not be done again until redeployment.

## Section III OPERATION UNDER USUAL CONDITIONS

Subject	Para	Page
Unpacking . . . . .	2-4	2-7
Siting . . . . .	2-5	2-9
Installation and Initial Checks . . . . .	2-6	2-10
Operating Procedure . . . . .	2-7	2-13

### 2-4. UNPACKING.

#### **CAUTION**

Use care when unpacking to prevent possible damage to the equipment.

#### **NOTE**

There are 20 manual telephone switchboards packed in both CONUS and OCONUS shipments.

TOOLS: Metal strap cutters, nail pullers.

## 2-4. UNPACKING. (CONT)

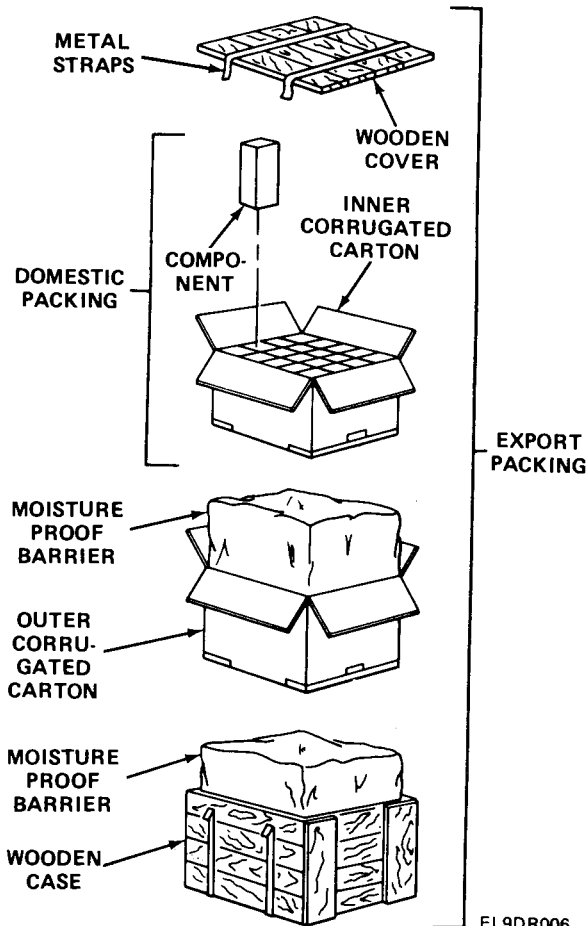



## **2-4. UNPACKING. (CONT)**

1. Using strap cutters, cut the metal straps around the wooden cover.
2. Using nail puller, remove the nails securing the top of the wooden case, then remove the top.
3. Open the moisture proof barrier and outer corrugated carton.
4. Open the inner moisture proof barrier and inner corrugated carton.
5. Remove the manual telephone switchboards, and check for damage and completeness.

## **2-5. SITING.**

### **WARNING**

Do not lay, place, or throw field wire on or near power lines or transformers. Dangerous high voltages exist at these structures, and severe shock or even death may result from contact between field wire and power lines. Follow the five emergency steps for electric shock in the front of this manual. Be careful when using the manual telephone switchboard during storms, as lightning may pose a shock hazard.

Position the switchboard and the operator's telephone set on a surface that keeps the equipment dry and operative.

## 2-5. SITING. (CONT)

### CAUTION

Do not support the full weight of the switchboard by the cover of the connector adapter holder.

When placed on a tree or post, position the switchboard above the operator's telephone.

## 2-6. INSTALLATION AND INITIAL CHECKS.

### INSTALLATION OF TELEPHONE SET

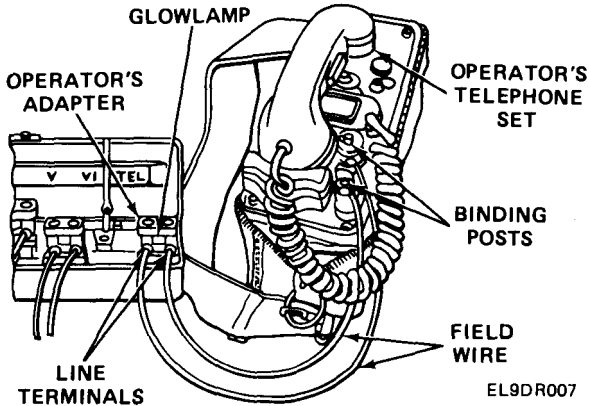

## **2-6. INSTALLATION AND INITIAL CHECKS. (CONT)**

**MATERIALS/PARTS:** Field wire, 2 pieces (approx. 4 feet long)

1. Remove 1 1/4 inch of insulation approximately 3 inches from each end.
2. At the bare portion, double over and flatten the wire.
3. Loosen plugs on operator's connector adapter.
4. Insert the ends of each wire in the operator's connector adapter line terminal.
5. Tighten the plugs to secure the field wire.
6. Using thumb pressure, open the binding posts on the operator's telephone sets.
7. Insert the other end of the field wire into the binding post and release thumb pressure.

### **CHECKING CONNECTOR ADAPTERS**

#### **NOTE**

If the glowlamp fails to light, discard the adapter.

1. Plug the operator adapter into the TEL jack.
2. Ring the hand generator several times. The glowlamp should light when current is applied.
3. Plug other adapters into the operator adapter and repeat step 2. These adapters should light also.

## 2-6. INSTALLATION AND INITIAL CHECKS. (CONT)

### INSTALLATION OF CONNECTOR ADAPTERS

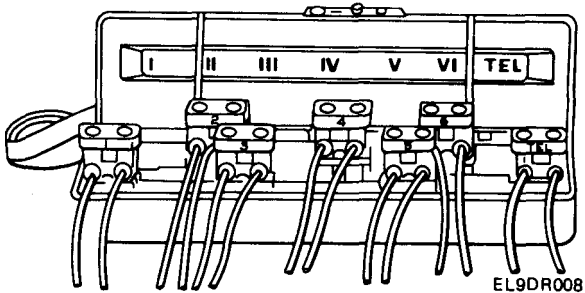

1. Connect the incoming lines to the adapters with the designation strip facing the operator.

### NOTE

Allow enough slack to form drip loop as well as free movement of adapters.

2. Identify each adapter. Mark the operator's telephone adapter "TEL" and remain numerals I, II, III, IV, V and VI on the remaining adapters.
3. Place each adapter in its corresponding jack in the switchboard. Be sure the marked side of the adapter faces the operator.

## 2-7. OPERATING PROCEDURES.

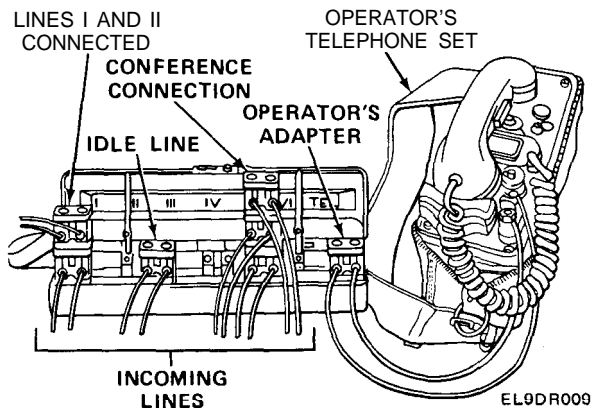

### LINE-TO-LINE CONNECTION

1. When an incoming signal to the switchboard is received, the glowlamp in the adapter of the calling line will light.
2. Insert the plug of the operator's adapter into the jack of the calling line adapter.
3. Using the operator's telephone, answer the incoming call and ask for the number being called.
4. Remove the operator plug from the calling line adapter jack end, and insert into the called lined adapter jack.
5. Turn the hand ringing generator of the operator's telephone set to signal the called line telephone set.

## **2-7. OPERATING PROCEDURES. (CONT)**

6. When the called line telephone set answers, insert the adapter plug of the called line into the jack of the calling line adapter end. Report that the connection is ready.
7. Remove the operator's telephone adapter and return it to the TEL jack of the switchboard after the conversation has begun.
8. When a call is complete, the calling line will recall or ring-off, causing the glowlamps of both adapters to light.
9. Insert the operator's adapter into the attached adapters, and check if call is complete.
10. If complete, disconnect adapters and return them to their respective switchboard positions.

## **CONFERENCE CALL CONNECTIONS**

1. Using the operator's connector adapter, call each party and advise them to stand by for a conference call.
2. Insert each adapter into another until all parties are connected.
3. Notify the calling line that conference call connections have been established.
4. Remove and store operator's connector adapter.
5. When the call is completed, the calling party will recall or ring-off, causing the glowlamps in all the attached adapters to light.

## **2-7. OPERATING PROCEDURES. (CONT)**

6. Insert the operator's adapter into the attached adapters and check if call has been completed.
7. If complete, disconnect adapters and return them to their respective switchboard positions.

## **Section IV OPERATION UNDER UNUSUAL CONDITIONS**

### **2-8. EMERGENCY OPERATION.**

If the connector adapter holder is damaged or is unavailable, continued operation is possible by placing the adapters and operator's telephone on a dry insulated surface. Follow the procedures outlined in paragraph 2-7 for operating instructions.

## **CHAPTER 3**

### **OPERATOR MAINTENANCE**

#### **3-1. GENERAL.**

The maintenance responsibility for the manual telephone switchboard has been assigned to the operator. Tools or test equipment are not required to perform the maintenance requirements, and the operator must perform preventive maintenance checks and services as described in paragraph 2-3.

#### **3-2. CLEANING.**

#### **WARNING**

Adequate ventilation should be provided while using TRICHLOROTRIFLUOROETHANE. Prolonged breathing of vapor should be avoided. The solvent should not be used near heat or open flame, as the products of decomposition are toxic and irritating. Since TRICHLOROTRIFLUOROETHANE dissolves natural oils, prolonged contact with skin should be avoided. When necessary, use gloves (which the solvent cannot penetrate). If the solvent is taken internally, consult a physician immediately.



### 3-2. CLEANING. (CONT)

#### **WARNING**

Compressed air shall not be used for cleaning purposes except where reduced to less than 29 pounds per square inch and then only with effective chip guarding and personnel protective equipment. Do not use compressed air to dry parts when TRICHLOROTRIFLUOROETHANE has been used. Compressed air is dangerous and can cause serious bodily harm if protective means or methods are not observed to prevent chip or particle (of whatever size) from being blown into the eyes or unbroken skin of the operator or other personnel.

Use solvent to clean metal surfaces and dry with compressed air.

Remove all rust and carrosian from metal surfaces by lightly sanding them with sandpaper. (Use sandpaper listed in appendix D, item 2.) Refinish by brushing two light coats of paint on bare metal. Refer to TM 43-0139, Painting Instructions For Field Use.

## **CHAPTER 4**

### **ORGANIZATIONAL MAINTENANCE**

#### **4-1. GENERAL.**

There are no scheduled organizational preventive maintenance checks and services on the manual telephone switchboard. The operator will perform PMCS and general maintenance.

#### **4-2. INSPECTION CRITERIA.**

Repair of the switchboard is limited to the replacement and disposal of parts. Therefore, organizational level maintenance personnel will inspect and replace those parts that are not serviceable. Use the PMCS table (page 2-6) as a guide for serviceability limits and for determining if complete replacement of the switchboard is necessary.

# APPENDIX A

## REFERENCES

Following is a list of references available to the operator and organizational repairman of the Manual Telephone Switchboard SB-993/GT.

Consolidated Index of Army  
Publications and Blank Forms . . . . . DA PAM 310-1

The Army Maintenance  
Management System (TAMMS) . . . . . TM 38-750

Painting Instructions For  
Field Use . . . . . TM 43-0139

Procedures For Destruction of  
Electronic Materiel to Prevent  
Enemy Use . . . . . TM 750-244-2

Administrative Storage of  
Equipment . . . . . TM 740-90-1

Operator's, Organizational, and  
Direct Support Maintenance  
Manual, Telephone  
Set TA-43/PT . . . . . TM 11-5805-256-13  
TO-31W1-2PT-1041

# APPENDIX B

## MAINTENANCE ALLOCATION

---

### **Section I. INTRODUCTION**

#### B-1. General

This appendix provides a summary of the maintenance operations for the SB-993/GT. It authorizes categories of maintenance for specific maintenance functions on repairable items and components and the tools and equipment required to perform each function. This appendix may be used as an aid in planning maintenance operations.

#### B-2. Maintenance Function

Maintenance functions will be limited to and defined as follows:

*a. Inspect.* To determine the serviceability of an item by comparing its physical, mechanical, and/or electrical characteristics with established standards through examination.

**B-0**

*b. Test.* To verify serviceability and to detect incipient failure by measuring the mechanical or electrical characteristics of an item and comparing those characteristics with prescribed standards.

*c. Service.* Operations required periodically to keep an item in proper operating condition, i.e., to clean (decontaminate), to preserve, to drain, to paint, or to replenish fuel, lubricants, hydraulic fluids, or compressed air supplies.

*d. Adjust.* To maintain, within prescribed limits, by bringing into proper or exact position, or by setting the operating characteristics to the specified parameters.

*e. Align.* To adjust specified variable elements of an item to bring about optimum or desired performance.

*f. Calibrate.* To determine and cause corrections to be made or to be made or to be adjusted on instruments or test measuring and diagnostic equipments used in precision measurement. Consists of comparisons of two instruments, one of which is a certified standard of known accuracy, to detect and adjust any discrepancy in the accuracy of the instrument being compared.

*g. Install.* The act of emplacing, seating, or fixing into position an item, part, module (component or assembly) in a manner to allow the proper functioning of the equipment or system.

*h. Replace.* The act of substituting a serviceable like type part, subassembly, or module (component or assembly) for an unserviceable counterpart.

*i. Repair.* The application of maintenance service (inspect, test, service, adjust, align, calibrate, replace) or other maintenance actions (welding, grinding, riveting, straightening, facing, remachining, or resurfacing) to restore serviceability to an item by correcting specific damage, fault, malfunction, or failure in a part, subassembly, module (component or assembly), end item, or system.

*j. Overhaul.* That maintenance effort (service/action) necessary to restore an item to a completely serviceable/operational condition as prescribed by maintenance standards (i.e., DMWR) in appropriate technical publications. Overhaul is normally the highest degree of maintenance performed by the Army. Overhaul does not normally return an item to like new condition.

*k. Rebuild.* Consists of those services/actions necessary for the restoration of unserviceable equipment to a like new condition in accordance with original manufacturing standards. Rebuild is the highest degree of materiel maintenance applied to Army equipment. The rebuild operation includes the act of returning to zero those age measurements (hours, miles,

etc.) considered in classifying Army equipment/components.

### B-3. Column Entries

*a. Column 1, Group Number.* Column 1 lists group numbers, the purpose of which is to identify components, assemblies, subassemblies, and modules with the next higher assembly.

*b. Column 2, Component/Assembly.* Column 2 contains the noun names of components, assemblies, subassemblies, and modules for which maintenance is authorized.

*c. Column 3, Maintenance Functions.* Column 3 lists the functions to be performed on the item listed in column 2. When items are listed without maintenance functions, it is solely for purpose of having the group numbers in the MAC and RPSTL coincide.

*d. Column 4, Maintenance Category.* Column 4 specifies, by the listing of a "work time" figure in the appropriate subcolumn(s), the lowest level of maintenance authorized to perform the function listed in column 3. This figure represents the active time required to perform that maintenance function at the indicated category of maintenance. If the number or complexity of the tasks within the listed

maintenance function vary at different maintenance categories, appropriate "work time" figures will be shown for each category. The number of task-hours specified by the "work time" figure represents the average time required to restore an item (assembly, subassembly, component, module, end item or system) to a serviceable condition under typical field operating conditions. This time includes preparation time, troubleshooting time, and quality assurance/quality control time in addition to the time required to perform the specific tasks identified for the maintenance functions authorized in the maintenance allocation chart. Subcolumns of column 4 are as follows:

- C - Operator/Crew
- O - Organizational
- F - Direct Support
- H - General Support
- D - Depot

*e. Column 5, Tools and Equipment.* Column 5 specifies by code, those common tool sets (not individual tools) and special tools, test, and support equipment required to perform the



designated function.

*f. Column 6, Remarks.* Column 6 contains an alphabetic code which leads to the remarks in section IV, Remarks, which is pertinent to the item opposite the particular code.

#### **B-4. Tool and Test Equipment Requirements (Sect. III)**

*a. Tool or Test Equipment Reference Code.*

The numbers in this column coincide with the numbers used in the tools and equipment column of the MAC. The numbers indicate the applicable tool or test equipment for the maintenance functions.

*b. Maintenance Category.* The codes in this column indicate the maintenance category allocated the tool or test equipment.

*c. Nomenclature.* This column lists the noun name and nomenclature of the tools and test equipment required to perform the maintenance functions.

*d. National/NATO Stock Number.* This column lists the National/NATO stock number of the specific tool or test equipment.

*e. Tool Number.* This column lists the manufacturer's part number of the tool followed by the Federal Supply Code for manufacturers (5-digit) in parentheses.

## **B-5. Remarks (Sect. IV)**

*a. Reference Code.* This code refers to the appropriate item in section II, column 6.

*b. Remarks.* This column provides the required explanatory information necessary to clarify items appearing in section II.

**Section II MAINTENANCE  
ALLOCATION CHART**

GROUP NUMBER	COMPONENT/ ASSEMBLY	MAINTENANCE FUNCTION	MAINTENANCE					TOOLS AND EQPT	REMARKS
			C	O	F	H	D		
00	Switchboard, Telephone, Manual SB-993/GT	Inspect Replace	•	•				1	A

**Section III TOOL AND TEST EQUIPMENT  
REQUIREMENTS FOR SB-993/GT**

TOOL OR TEST EQUIPMENT REF CODE	MAINTENANCE CATEGORY	NOMENCLATURE	NATIONAL/ NATO STOCK NUMBER	TOOL NUMBER
1	0	Tool Equipment TE-111		

**Section IV REMARKS**

REFERENCE CODE	REMARKS
A	There is no repair authorized at the organizational level. Repair is limited to inspection and disposal of switchboard.

## APPENDIX C

# COMPONENTS OF END ITEM AND BASIC ISSUE ITEMS LISTS

---

### Section I. INTRODUCTION

#### C-1. Scope

This appendix lists integral components of and basic issue items for the Telegraph Terminal SB-993/GT to help you inventory items required for safe and efficient operation.

#### C-2. General

**This Components of End Item List is divided into the following sections:**

*a. Section II.* This listing is for informational purposes only, and is not authority to requisition replacements. These items are part of the end item, but are removed and separately packaged for transportation or shipment. As part of the end item, these items must be with the end item whenever it is issued or transferred between property accounts. Illustrations are furnished to assist you in identifying the items.

*b. Section III. Basic Issue Items.* These are the minimum essential items required to place the SB-993/GT in operation, to operate it, and to perform emergency repairs. Although shipped separately packed they must accompany the SB-993/GT during operation and whenever it is transferred between accountable officers. The illustrations will assist you with hard-to-identify items. This manual is your authority to requisition replacement BII, based on TOE/MTOE authorization of the end item.

### **C-3. Explanation of Columns**

*a. Column (1) - Illustration Number (Illustration Number).* This column indicates the number of the illustration in which the item is shown.

*b. Column (2) - National Stock Number.* indicates the National stock number assigned to the item and will be used for requisitioning purposes.

*c. Column (3) - Description.* Indicates the National item name and, if required, a minimum description to identify and locate the item. The last line for each item indicated the FSCM (in parentheses) followed by the part number.

*d. Column (4) - Unit of Measure (U/M).* Indicates the measure used in performing the actual operational/maintenance function. This measure is expressed by a two-character

alphabetical abbreviation (e. g., ea, in, pr).

*e. Column (5) - Quantity required (Qty Rqd).*

Indicates the quantity of the item authorized to be used with/on the equipment.

n authorized by a modification work order which is listed in DA Pam 310-1.

## Section II COMPONENTS OF END ITEM LIST

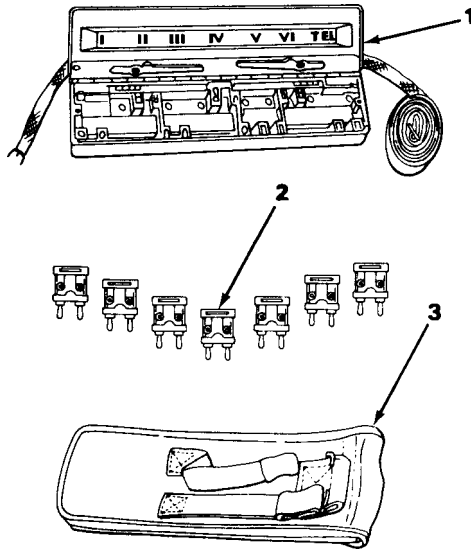

EL9DR010



**MANUAL TELEPHONE SWITCHBOARD SB-993/GT,  
COMPONENTS.**

(1) ILLUS NUMBER	(2) NATIONAL STOCK NUMBER	(3) DESCRIPTION FSCM AND PART NUMBER	USABLE ON CODE	(4) U/M	(5) QTY REQD
1	5805-00-708-2204	Holder, Connector Adapter MT-2156/GT		ea	1
2	5805-00-708-2203	Connector Adapter U-184/GT		ea	7
3	5805-00-681-9874	Case, Switchboard CY-2589/GT		ea	1

## **APPENDIX D**

### **ADDITIONAL AUTHORIZATION LIST**

---

#### **Section I INTRODUCTION**

##### **D-1. SCOPE.**

This appendix lists additional items you are authorized for the support of the Manual Telephone Switchboard SB-993/GT.

##### **D-2. GENERAL.**

This list identifies items that do not have to accompany the switchboard and that do not have to be turned in with it. These items are all authorized to You by CTA, MTOE, TDA, or JTA.

##### **D-3. EXPLANATION OF LISTING.**

National stock numbers, descriptions, and quantities are provided to help you identify and request the additional items you require to support this equipment. The items are listed in alphabetical sequence by item name under the type document (i.e., CTA, MTOE, TDA, or JTA) which authorizes the item(s) to you.

##### **D-0**

## Section II ADDITIONAL AUTHORIZATION LIST

(1) NATIONAL STOCK NUMBER	(2) DESCRIPTION FSCM & PART NUMBER      USABLE ON CODE	(3) U/M	(4) QTY AUTH
5805-00- 503-2775	Telephone Set TA-43/PT	ea	1

# APPENDIX E

## EXPENDABLE SUPPLIES AND MATERIALS LIST

---

### Section I INTRODUCTION

#### E-1. SCOPE.

This appendix lists expendable supplies and materials you will need to operate and maintain the Manual Telephone Switch board SB-993/GT. These items are authorized to you by CTA 50-970, Expendable Items (except medical, class V, repair parts, and heraldic items).

#### E-2. EXPLANATION OF COLUMNS.

a. Column (1), Item number. This number is assigned to the entry in the listing and is referenced in the narrative instructions to identify the material (e.g., Use cleaning compound, item 5, app. E).

b. Column (2), Level. This column identifies the lowest level of maintenance that requires the listed item.

C - Operator/Crew

O - Organizational Maintenance

c. Column (3), National Stock Number. This is the national stock number assigned to the item, use it to request or requisition the item.

**E - 0**

## **E-2. EXPLANATION OF COLUMNS. (CONT)**

d. Column (4), Description. Indicates the federal item name and, if required, a description to identify the item. The last line for each item indicates the Federal Supply Code for Manufacturer (FSCM) in parentheses followed by the part number.

e. Column (5), Unit of Measure (U/M). Indicates the measure used in performing the actual maintenance function. This measure is expressed by a two-character alphabetical abbreviation (e.g., ea, in, pr). If the unit of measure differs from the unit of issue, requisition the lowest unit of issue that will satisfy your requirements.

**Section II EXPENDABLE SUPPLIES AND  
MATERIALS LIST**

(1) ITEM NUMBER	(2) LEVEL	(3) NATIONAL STOCK NUMBER	(4) DESCRIPTION	(5) U/M
1	C	6850-00-105-3089	Cleaning Solvent, Trichlorotrifluoroethane	pt
2	C	5350-00-598-5908	Sandpaper No. 000	sh

By Order of the Secretary of the Army:

JOHN A. WICKHAM, JR.  
*General, United States Army*  
*Chief of Staff*

Official:

ROBERT M. JOYCE  
*Major General, United States Army*  
*The Adjutant General*

DISTRIBUTION:

To be distributed in accordance with Special List.

☆ U.S. GOVERNMENT PRINTING OFFICE: 1990-261-872/20745







PIN : 053746-000